

Enervent Pegasus XL

COMPREHENSIVE TECHNICAL DETAILS



enervent

Enervent Pegasos XL

The Enervent Pegasos XL unit is best suited for large detached houses and public spaces, such as schools and kinder gardens. Pegasos XL can be fitted with a built-in extract air heat pump (HP). All heating and cooling coils, as well as the heat pump unit, are built-in to the unit. The Pegasos HP with a built-in heat pump effectively cools and heats the air on demand. The cooled and heated air is evenly distributed throughout the building via the ventilation ducts (not local point formed distribution, as in traditional heat pumps). In addition, the heat pump offers the unique feature of heating water (Aqua). The water can be used as domestic hot water or in a water-borne heating system.

Enervent Pegasos XL is a 'non-residential ventilation unit' (NRVU) according to the EU Commission Regulation No 1253/2014. Ventilation units with maximum flow rate between 250 and 1 000 m³/h which the manufacturer has not declared intended as being exclusively for a residential ventilation application are called non-residential.

Non-residential ventilation units (NRVUs) are excluded from EcoDesign labelling.

Our calculation software Energy Optimizer, located on our website www.enervent.com, reports whether the chosen NRVU unit fulfills the EcoDesign requirements or not for the intended project.

Technical details

General information

Air volume flow	140...1 404 m ³ /h
Pressure difference	50 to 125 Pa
Leakage	external < 5% (test pressure 300Pa) internal < 5%
Duct size	Ø 250 mm
Weight	203 kg
Standard filters, 2 x bag filter Filter dimensions (WxHxD)	F7/M5 Supply 287 x 592 x 305 mm Extract 287 x 538 x 340 mm
IP class	IP44 (external control IP20)
Water heating coil connections	Intake/return 20 mm
Water cooling coil connections	Intake/return 20 mm
Evaporator connections	Intake ½", return 20 mm
Condense connection	¼" internal thread
Nominal voltage	230 V, models with electrical heater 400 V
Nominal current	Motors 6.6 A total Electrical after heating 10 A

Fans

Supply and exhaust air fan type	Ebm-Papst
Supply and exhaust air motor type	G3G225-AD29-71 (EC type)
Nominal voltage	230 V (AC)
Type of fan blade	Radial forward
Nominal power	545 W
Fan control eWind control	4 situations (away, home, boost, timer controlled boost). In each situation both fans can be fine adjusted separately.
Fan control eAir control	Stepless (supply and exhaust running separately)

Heat exchanger

Heat exchanger type	Rotating heat exchanger
Material	Aluminium
Heat exchanger surface	92 m ²
Heat exchanger dimensions	520 x 200 (60 µ)
Heat exchanger motor	6 W
Ventilation unit annual temperature efficiency (EN 13141-7:2010)	76,3 %
Supply air annual heat recovery efficiency* (EN 16798-3:2017)	90 %
Extract air annual heat recovery efficiency* (D5:2012)	76,2 %

* supply air +18°C, extract air +21°C, exhaust air temperature limit -7°C

Other information

Material inside cover	Steel sheet, zinc coated
Material outside cover	Steel sheet, zinc coated, powder painted
Sound level in supply air duct at fan speeds 20, 40, 60, 80 and 100% LWA	41, 45, 58, 66, 68 dB(A)
LPA, dB(A), 10 m ² : sound absorption	40, 38, 47, 52, 55 dB(A)
Standard electric after heater efficiency	4 000 W
Positioning of a cooling (CG) coil	Duct
Duct cooler measurements (WxHxL), mm	600x550x890 mm



Dimension drawings

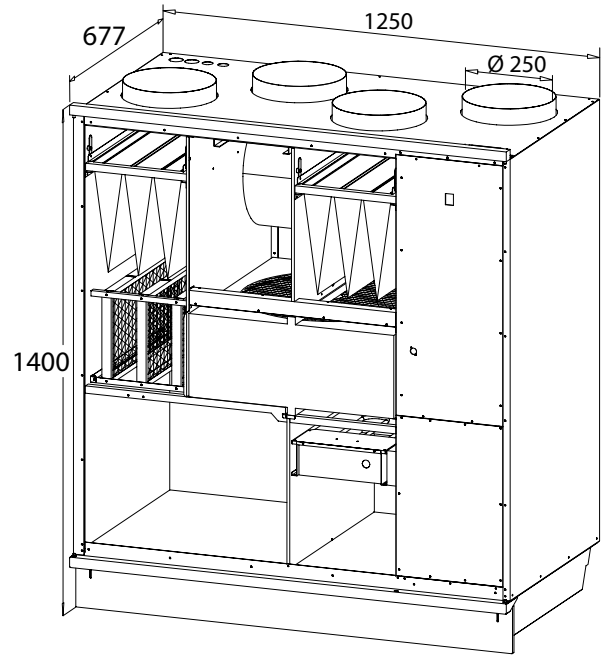

Characteristics

Pegasos XL supply and extract air characteristic curves with M5/M5 filters

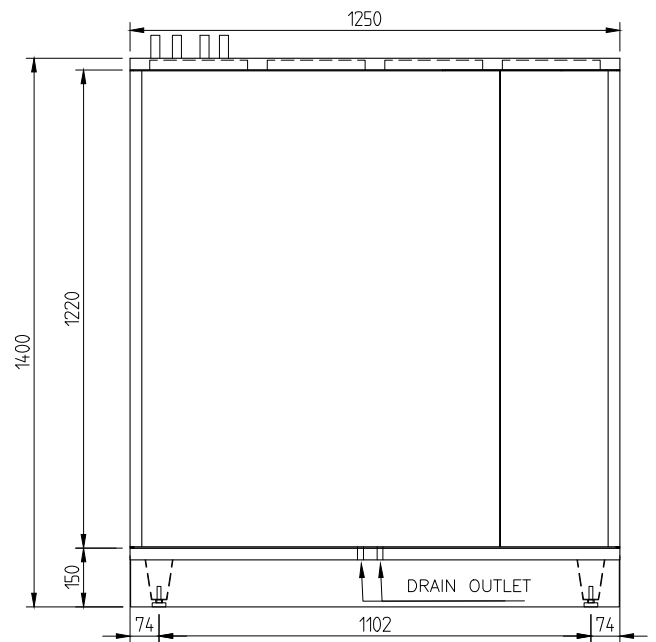
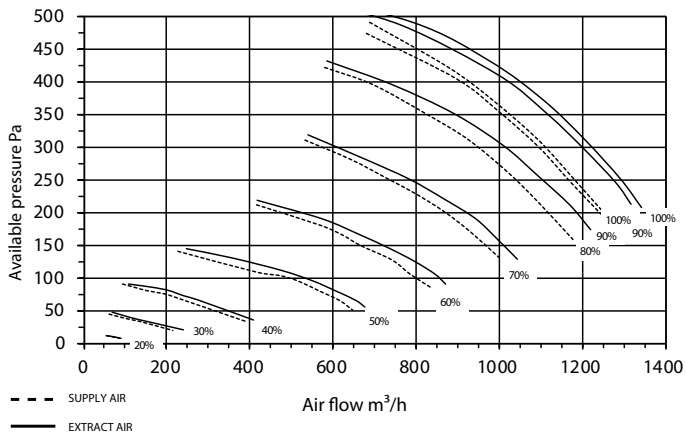

Installation

Mounting	Floor	X	Wall		Ceiling
Frame alternatives			Right	X	Left

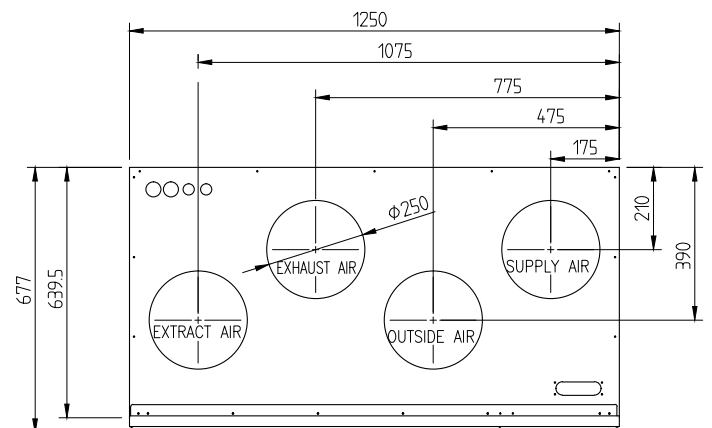

Enervent Zehnder Oy
Kipinätie 1
FI-06150 Porvoo, Finland
Tel: +358 207 528 800
enervent@enervent.com
www.enervent.com

enervent