

Enervent eAir

ENG Installation instruction



enervent

PART OF ENSTO

ENGLISH.....	5
Read me first.....	6
Explanation of the type designation.....	6
Warnings.....	6
General.....	6
Electrical.....	6
Terminology.....	7
Before installing unit.....	7
Selecting installation location.....	7
Pinion, Pingvin, Pingvin XL, Pandion, Pelican, Pegasos, Pegasos Twin Tropic and Pallas.....	7
LTR-2, LTR-3, LTR-4, LTR-6 and LTR-7.....	8
Building the ventilation system.....	9
Insulating ventilation ducts.....	9
Installing duct coils.....	10
Installing ventilation unit ceiling installation plate (OPTIONAL).....	12
Installing geo-cooling equipment.....	12
Installing CHG geothermal pre-heating / pre-cooling equipment.....	13
Requirements and preparations for electrical connections .	14
Preparatory electrical work.....	14
Installation.....	18
Additional materials needed for installation.....	18
Installing models Pinion, Pingvin, Pingvin XL, Pandion, Pelican, Pegasos, Pegasos Twin Tropic and Pallas.....	19
Wall installation.....	19
Ceiling installation.....	19
Floor installation.....	21
Installing models LTR-2, LTR-3, LTR-4, LTR-6 and LTR-7.....	21
Draining condensate water.....	21
Further installation phases:	
models MD and MDE.....	23
Installing model MDW.....	23
Installing model CG, TCG and Twin Tropic CW.....	24
Installing model ION.....	24
Commissioning.....	25
Calibrating airflow.....	25
Commissioning checklist.....	25
Control system.....	26
Commissioning eAir control panel.....	26
Important to know about control system.....	26
Setting up system with setup wizard.....	27
Setting up system without setup wizard.....	34
Documenting commissioning.....	36
Use.....	36
General.....	36
Using eAir control panel.....	37
Description of operations.....	37
Operations.....	37

TCG units.....	38
Twin Tropic units	38
Fans.....	38
Constant duct pressure control	38
CO ₂ , humidity and temperature boosting of fans	38
Extra time (Office mode).....	39
Overpressure (lighting fireplace)	39
Manual boosting	39
Cooker hood and central vacuum cleaner modes.....	39
Summer night cooling.....	39
Weekly and annual program	39
Temperature control.....	40
Alarms	41
Maintenance	41
Changing filters	41
Cleaning heat exchanger	42
Cleaning fans.....	42
Service of ionizer module.	42
Technical information and attachments.....	43
Table 1: Afterheating and cooling duct coils	44
Table 2: Preheating and precooling coils.....	45
Extra equipment available	47
Troubleshooting	48
Models and components.....	53
Technical features.....	59
Dimensional drawings	65
Wiring diagrams	83
MD basic electric diagrams	84
MD preheater electric diagrams.....	89
TCG differing electric diagrams.....	92
Pallas differing electric diagrams	94
Twin Tropic differing electric diagrams	98
Miscellaneous electrical connections.....	101
Principal diagrams	107
Control diagrams	123
MD adjustment charts	125
Pallas adjustment charts	130
Twin Tropic adjustment chart	136
Table of parameters.....	137
Record of measuring air amounts and sound levels	140
EU declaration of conformity.....	141
Representatives for the products outside Finland	142

Read me first

This document is intended for everyone involved in installation of Enervent ventilation units. The equipment described in this manual is to be installed by skilled persons only, according to the instructions given in this manual, and local law and regulations. Failure to comply with instructions in this manual will void the warranty of the equipment, and possibly result in harm to people or property.

The equipment described in this manual is not to be used by persons (including children) with reduced physical, sensory or mental capabilities, or lack of experience and knowledge, unless they have been given supervision or instruction concerning use of the equipment by a person responsible for their safety.



Tables at the end of this manual list

- ventilation units introduced in this document
- components that are included in the delivery



NOTE: If your delivery does not include all the components listed in the *Models and components* table at the end of this manual, check your order and contact your seller or Ensto Enervent before starting installation.

The type plate is located near the main power switch or inside the ventilation unit. Before you start reading, please check the type marking of the unit.

enervent ilmastointilaite ventilation unit
TYYPPI/TYYPE: SRJ.NRO/SERIAL NO: W/V/HZ/A:
  ENSTO ENERVENT OY KIPINÄTIE 1 06150 PORVOO TEL +358 (0)207 528800 FAX +358 (0) 207 528844

Explanation of the type designation

- The first part of the type designation indicates the chassis of the ventilation unit, for instance LTR-3, or Pandion
- The next two letters indicates the type of automation the ventilation unit is equipped with, in this case MD.

- The next letter of the type designation indicates the type of afterheater the ventilation unit is equipped with, E= electrical, W= water.
- The next two separate letters indicate if the ventilation unit is equipped with cooling =C, and type of cooling the ventilation unit is equipped with, G= geothermal cooling, W= cooling with water, O= integrated heatpump for cooling in Pegasos ventilation units. There can also be the letters XL in the type designation. This indicates that the ventilation unit is equipped with more powerful fans than normally. Example: Pegasos XL MDE-CG means a ventilation unit with Pegasos chassis, equipped with MD automation, electrical afterheater, and geothermal cooling functionality. Additionally the ventilation unit is equipped with more powerful fans.

Warnings

General



WARNING: Before opening the maintenance hatch, always make sure that the unit's supply voltage has been switched off.



WARNING: In case of malfunction, always find out the cause for it before restarting the unit!



WARNING: After switching off the unit power, wait two (2) minutes before starting maintenance work. Even though the power is switched off, the fans continue spinning and the afterheater coil may remain hot for some time.





WARNING: All ventilation units that come with a water coil must be equipped with dampers to avoid freezing of the coil during possible power failure.

Electrical



WARNING: Do not open the electrical box unless you are a qualified electrician.

 **WARNING:** Make sure you follow the local regulations for electrical installations.

 **WARNING:** Make sure the unit is fully detached from the electrical network before carrying out voltage tests, insulation resistance measuring or other electrical work or measuring. This kind of work may cause damage to sensitive electronic equipment.

 **WARNING:** Control equipment used in ventilation units may cause leakage current. This may affect the functionality of fault current protection.

 **WARNING:** All ventilation units that come with an MD control system must be equipped with over voltage protection.

Term	Explanation
outside air	Outside air supply to ventilation unit
underpressure prevention	Actions taken for avoiding excessive under pressure climate inside when one or several appliances are extracting air in addition to the ventilation unit.
summer night cooling	Cooling method that utilizes cool outside air when the outside temperature is lower than the inside temperature.
supply air	Inbound air flow to rooms.
%RH	Relative humidity percent that is used here for determining whether ventilation should be boosted to remove excessive humidity.

Terminology

Term	Explanation
active cooling	Cooling created by a cooling unit included in some ventilation units.
after heating	After heating warms the air after the heat recovery wheel. It ensures that the incoming air is not too cold. After heating can be realized with either an electrical or water coil. Suitable temperature for the incoming air is 5°C less than the room temperature if no extra heating of the room is desired.
click models	New ceiling installation method for models Pingvin and Pandion.
eAir	Control panel for managing the ventilation unit.
exhaust air	Air removed from house after heat recovery.
extract air	Outbound air flow from rooms.
Modbus	Communication protocol that is used here for communication between the ventilation unit and home automation systems (+ possible accessories).

Before installing unit

Selecting installation location

Before you start installing the ventilation unit, make sure the installation location is suitable for the model you are installing.

Pinion, Pingvin, Pingvin XL, Pandion, Pelican, Pegasos, Pegasos Twin Tropic and Pallas

The ventilation unit can be installed

- on the wall (Pinion, Pingvin, Pingvin XL and Pandion)
- hanging from the ceiling (Pinion, Pingvin, Pingvin XL and Pandion), requires ceiling installation plate, (sold as accessory)
- on the floor (Pandion, Pelican, Pegasos and Pallas), or
- on a suitable, flat plane.

Ventilation unit models Pinion, Pingvin, Pingvin XL, Pandion, Pelican, Pegasos, Pegasos Twin Tropic and Pallas need to be installed in a warm space (over +5°C):

- We recommend the unit is installed in a technical space if one is available.

- Avoid installing the unit in spaces with high temperature and high humidity level. In certain conditions these can cause condensation on the unit's outer shell.
- Consider the unit noise level when choosing the installation location. If possible install the unit on a soundproof wall. Avoid installing the ventilation unit directly outside a bedroom, since even though the ventilation unit is quiet, it can never be completely silent.
- Install an insulating plate at the back of the ventilation unit, or otherwise try to prevent structure borne noise. Soft, foamed plastic sheets are recommended for this (not included in the delivery).
- Make sure it is possible to connect the condensate water drain and water lock and consider the space needed for it.
- Make sure to install fire shutoff valves if the unit is placed in a separate fire area.
- Units mounted on the wall are recommended to be installed on a partition wall rather than on an exterior wall.
- Consider the unit maintenance tasks when installing the unit: Doors of the unit need to be fully opened for maintenance work. Leave minimum 15 mm space surrounding the ventilation unit to the sides. Otherwise the service doors cannot be fully opened.
- Consider the space needed for duct coils (if included).

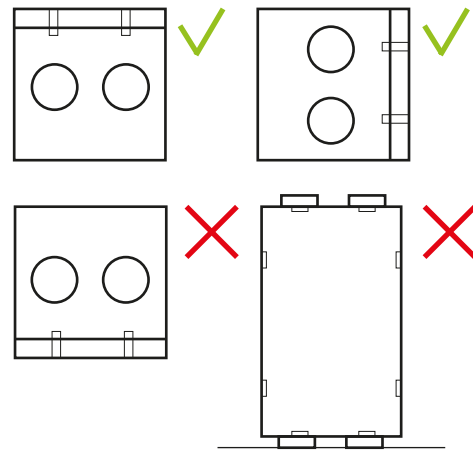

LTR-2, LTR-3, LTR-4, LTR-6 and LTR-7

LTR-2, LTR-3, LTR-4, LTR-6 and LTR-7 ventilation units can be installed in either warm or cold space.

All LTR-2, LTR-3 and LTR-4 units can be installed in two positions: maintenance hatch up or on the side.

Standard LTR-6 and LTR-7 unit can be installed with the maintenance hatch up. On request, units can be made for installation with the hatch on the side. This must be mentioned when the unit is ordered. LTR-4, LTR-6 and LTR-7 ventilation units equipped with built in cooling coil are recommended to order with the maintenance hatch to the side. This will enable the condensation formed in the cooling coil to drain more easily.



WARNING: Do not install any LTR units so that the maintenance hatch is facing downwards or so that the unit is standing upright. Always make sure one of the condensate water drains is downwards.

- Installation location for LTR units can be for example in a storage space or attic.
- Insulate the unit with a minimum of 100 mm extra layer of insulation, if it will be installed in a space where the temperature drops below +5°C. If you are using solid (hard) insulation, make sure the insulation does not carry sound to the frame of the house.
- Avoid installing the unit in spaces with high temperature and high humidity level. In certain conditions these can cause condensation on the unit's outer shell.
- Consider the unit noise level when choosing the installation location. Avoid installing the ventilation unit directly outside a bedroom, since even though the ventilation unit is quiet, it can never be completely silent.
- Set the unit on top of a sound-proofing 100 mm insulation.
- Make sure it is possible to connect the condensate water drain and water lock and consider the space needed for it.
- Make sure to install fire shutoff valves if the unit is placed in a separate fire area.
- Consider the unit maintenance tasks when installing the unit:
 - Make sure that there is enough space in front of or above the maintenance hatch:
 - LTR-2 and LTR-3 min. 50 cm
 - LTR-4 and LTR-6 min. 60 cm
 - LTR-7 min. 70 cm
 - Make sure the electrical connections can be easily accessed.
 - Take into account the space needed for opening the maintenance hatch locking latches.
- Consider the space needed for duct coils (if included).

Building the ventilation system

Designing the ventilation system must be done by a professional ventilation designer. By following closely the design plan when building the ventilation system, you ensure the operation of the whole ventilation system and customer satisfaction. Use the Enervent Energy Optimizer calculation program at the Enervent home page to calculate the performance and estimated heating/cooling power of a particular ventilation unit.

- Use type-approved factory made materials when building the ventilation system.
- Use valves that are suitable for mechanical ventilation
- Do not cover the outside air grating with mosquito net. This would make it very difficult to keep clean.
- Prevent rain water and snow from entering the outside air and exhaust air duct.
- Install enough inspection hatches in the ventilation network to enable cleaning of the ventilation ducts.
 - To make it easier to find the inspection hatches, mark their location for example on the rafters.
- Ventilation systems for different fire zones must be separate. For example garage is one fire zone whereas living quarters are another fire zone, which means that they cannot be connected to the same ventilation system.
- Use a cooker hood with its own fan in the kitchen, above the stove. The cooker hood should have its own extract duct directly out. A motorless cooker hood can be connected to the ventilation unit only if the ventilation unit has a cooker hood connection.
- A drying cabinet with its own fan can be indirectly connected to the outlet valve using the connection system that comes with the drying cabinet. If this is done, some of the extract air will be taken from the living space and some from the drying cabinet. The extract air must flow through the valve at a speed of 12 litres / second minimum
- Install silencers at least in the supply and extract ducts.
 - The amount of silencers must be considered case by case.
- We recommend that automatically closing dampers are installed in outside and exhaust air ducts. In case of a power failure, the dampers will close and block out cold air, preventing any water coil from freezing. If cold air gets into ventilation ducts, it will create condensate when mixing with warm air.
- Install pressure-difference transmitters in the ducts if the unit is to be constant duct pressure controlled.



NOTE: The ventilation ducts must be plugged close until the ventilation system is taken into use. This is in order to keep warm air from flowing into the duct. Warm air causes condensation if it meets cold outside air or surfaces in the duct. Furthermore the plugging keeps dirt and other unwanted particles from clogging the system.

Insulating ventilation ducts

Insulate the ventilation ducts appropriately. This is especially important when the ventilation unit comes with cooling functionality.

Ventilation ducts must be thermally insulated to prevent water from condensing to the inner or external duct surfaces in any circumstances. Additionally, the air temperature must not decrease or increase excessively in the ducts because of external factors. The ventilation engineer calculates the insulation requirements depending on the placement of the ducts and the air temperatures.

Ventilation duct thermal insulation in heating use	
Supply air duct from the ventilation unit to the supply valve	The insulation must be designed and implemented so that the maximum air temperature change in the duct is less than 1°C.
Extract air duct from the extract valve to the ventilation unit	The insulation must be designed and implemented so that the maximum air temperature change in the duct is less than 1°C.

Ventilation duct thermal insulation in cooling use	
Supply air duct from the ventilation unit to the supply valve	The insulation must be designed and implemented so that the maximum air temperature change in the duct is less than 1°C. At least 18 mm of cellular rubber insulation on the duct surface and sufficient additional insulation.
Extract air duct from the extract valve to the ventilation unit	The insulation must be designed and implemented so that the maximum air temperature change in the duct is less than 1°C.

Ventilation Duct Insulation Examples

Sound insulation is not taken into account in these insulation instructions and examples.



NOTE: A semi-warm* space refers also to dropped ceilings, sub-floors, and casings.

Outside air duct (fresh air duct)

Cold spaces:

- 100 mm of sheet, mat, or pipe-covering insulation (plus the blown wool, when used).

Warm/semi-warm* spaces and also for dropped ceilings, sub-floors, and casings:

- Option 1: 80 mm insulation with vapour-proof external surface
- Option 2: 20 mm of cellular rubber insulation on the duct surface and 50 mm insulation with vapour-proof external surface.

The insulation must prevent water vapour from condensing to the external duct surface and excessive air temperature rise during summer.

Supply air duct

Cold/semi-warm* spaces and also for dropped ceilings, sub-floors, and casings:

- In standard ventilation the insulation must be designed and implemented so that the maximum air temperature change in the duct is less than 1°C. For example, 100 mm of sheet, mat, or pipe-covering insulation can be used (plus the blown wool, when used).

Warm spaces:

- Insulation is not required in standard ventilation.

In heating and cooling use see tables Ventilation duct thermal insulation in heating use and Ventilation duct thermal insulation in cooling use

Extract air duct

Warm spaces:

- Insulation is not required in standard ventilation.

Cold/semi-warm* spaces:

- In standard ventilation the insulation must be designed and implemented so that the maximum air temperature change in the duct is less than 1°C. For example, 100 mm of sheet, mat, or pipe-covering insulation can be used (plus the blown wool, when used).

In heating and cooling use see tables Ventilation duct thermal insulation in heating use and Ventilation duct thermal insulation in cooling use.

Exhaust air duct

Cold spaces:

- 100 mm of sheet, mat, or pipe-covering insulation

Warm/semi-warm spaces:

- Option 1: 80 mm insulation with vapour-proof external surface
- Option 2: 20 mm of cellular rubber insulation on the duct surface and 50 mm insulation with vapour-proof external surface.

The insulation must prevent water vapour from condensing to the external and internal duct surfaces.

Circulation air duct

The insulation must be designed and implemented so that the maximum air temperature change in the duct is less than 1°C. When Kotilämpö systems are renewed, the recycling air duct can be left as it is.

* semi-warm space = +5-+15°C



NOTE: Note that duct coils included in the ventilation system must be insulated the same way as the ducts.

Installing duct coils

Duct coils are used in several unit models both as pre heaters, afterheaters and coolers. For information what type of coils are used with your particular ventilation unit model, please refer to tables listing models with duct coils at the end of this manual. Check the principal diagrams at the end of this manual for correct mounting of duct coils.

Table 1 lists the ventilation unit models that come equipped with duct coils for after heating or cooling.

These coils are installed in the supply air duct (after the ventilation unit).

Table 2 shows preheating/precooling coils. These coils are installed in the outside air duct (before the ventilation unit).

Duct coils must be accommodated in the ventilation ducts. There must also be sufficient room for maintenance and draining condensate water.



NOTE: For more technical details about the coils, see the technical features table at the end of the manual.

Duct coil for fluids

When installing a duct coil

- Place the duct coil in the supply air duct after the ventilation unit or in the outside air duct before the ventilation unit depending on its function.
- Make sure there is a filter before pre-heater coils in the outside air duct to prevent dirt from entering the coil.
- Do not install the coil too close to a fan outlet or a bend in the ducting. This can result in lower efficiency.
- Connect the coil so that the system is easy to empty for maintenance.
- A duct heater can be fitted in a horizontal or a vertical duct with optional direction of airflow. To facilitate venting of the coil, the unit should be fitted with the longitudinal tubes horizontal.
- A duct cooler must be fitted in a horizontal duct and the airflow must be in the direction of the arrow. The cooler must be insulated externally to prevent the formation of condensation. The cooler must be connected to a condensate drain and water trap and tilted at an angle of 10-15 degrees to the horizontal in the direction of the drain.
- Insert the coil into standard spiral ducting and attach it to the ducting with screws. Support the weight of the coil.
- Connect the coil with clamping ring connectors.
- Connect the water inlet to the lowest pipe connector in order to facilitate venting of the coil.
- Consult the principal drawings at the end of the manual on how to construct the hydronic circulating system.
- Install a venting valve near the coil or at the highest point in the system.
- Check the duct coil and its connections for leaks immediately after the system has been filled with liquid.
- Place the supply air temperature sensor (TE10) in the duct after the coil, and the water coil return water sensor (TE45) on the return water pipe of the coil, if the coil is mounted in the supply air duct. Place the outside air temperature sensor (TE01) in the outside air duct before the coil, if the coil is mounted in the outside air duct.
- Connect the sensor to the ventilation unit control circuit board. Refer to the electrical schematics at the end of this manual for correct connections.

Electrical duct coils

- The heater is designed for insertion into standard spiral ducting and is fixed to the ducting with screws.
- The air must flow through the heater in the direction indicated by the arrow on the side of the connection box.
- The heater can be fitted in either horizontal or vertical ducting. The heater may only be fitted in ducts that are made of incombustible and heat-and-cold resistant material. The connection box can be freely placed facing upwards or sideways to a maximum angle of 90°.



WARNING: Fitting with the connection box facing downwards is NOT allowed.

- The distance from (to) the heater to (from) a duct bend, valve, filter, etc, should correspond to at least twice the duct diameter. Otherwise there is a risk that the airflow through the heater will be uneven which can cause activation of the overheating cut-out.
- The duct heater may be insulated in accordance with valid regulations for ventilation ducting. However, the insulation must be incombustible. The insulation must not cover the lid, since the rating plate must be visible and the lid must be removable. Furthermore, the insulation must not cover any heatsinks, nor the side of the connection box where the SCR's (Triac's) are mounted.
- The duct heater must be accessible for replacement and inspection.
- The distance from the heater metal casing to any wood or other combustible material must NOT be less than 30 mm.
- Install the duct sensor TE10 (delivered with the heater) in the duct after the heater, if the heater is mounted in the supply air duct. Or if the heater is mounted in the outside air duct, install the temper-

ature sensor (TE01) before the heater in the outside air duct and connect the sensor(s) to the MD control circuit board..



NOTE: We recommend installing a safety switch for the electric heater.

Installing ventilation unit ceiling installation plate (OPTIONAL)



NOTE: Ceiling installation plate is separately sold extra equipment available for ventilation unit models Pinion, Pingvin, Pingvin XL and Pandion.

Before attaching the ceiling installation plate

- Make sure that the ceiling is even so that the plate will be stable and straight after it has been installed.
- The gap between the plate and the back wall should be at least 10 mm (recommendation) and at least 15 mm between the plate and the side walls.
- Consider the height level of the final ceiling surface material. The top of the ceiling installation plate can be max 15 mm above the inner ceiling level.

To attach the ceiling installation plate,

1. Prepare holes in the ceiling for the ventilation ducts.
2. Attach the plate on the ceiling using screws that are suitable for the ceiling material.
3. Seal the ceiling installation plate against the ceiling's vapor barrier using for example duct tape.
4. Attach the ducts to the ceiling installation plate with rivets.

Make sure there are no gaps between the insulation and the ducts.

5. Consider the unit's weight when screwing the plate to the ceiling. The ceiling installation plate must be absolutely rigid. Weights for all units are found in the technical table in the end of this instruction.

Installing geo-cooling equipment

If a geothermal heat pump is in use, the cold brine in the ground loop can be used in the summertime to cool the incoming air. The system can be implemented in two ways: the solution can be circulated through the geothermal pump (option 1) or a separate pump

can be used (option 2). The cooling coil can be either built in the ventilation unit or it can be a duct coil, depending on the model. A duct coil is mounted in the supply air duct after the ventilation device. Standard ventilation unit delivery is according to option 2.

Detailed principal charts are found at the end of this manual.

Option 1:

A geothermal heat pump is used for circulating brine also in the supply air coil.

The delivery includes

- a relay for starting up the brine pump. The relay is situated on the unit motherboard, connection DO3.
- a 3-way control valve (Termomix D32S) needed for cooling and
- the actuator (Belimo NRYD24-SR-W + installation set MS-NRE).

Temperature is controlled using the ventilation unit's own automatic control. The ventilation unit controls the geothermal heat pump and the 3-way valve.

Installation:

1. Mount the cooling coil horizontally in the supply air duct (in case of a duct coil).

2. Isolate a separate loop for the cooling coil.

Don't forget the one-way valve. Follow the principal chart at the end of this manual.

3. Connect the condensate water outlet.

4. Install the 3-way valve and the actuator in the ground collector's piping. The actuator will control the brine flow to the cooling coil as needed. Be sure to isolate the pipes carefully with vapour proof insulation to prevent condensation on the outside of the pipes in warm and semi-warm spaces.

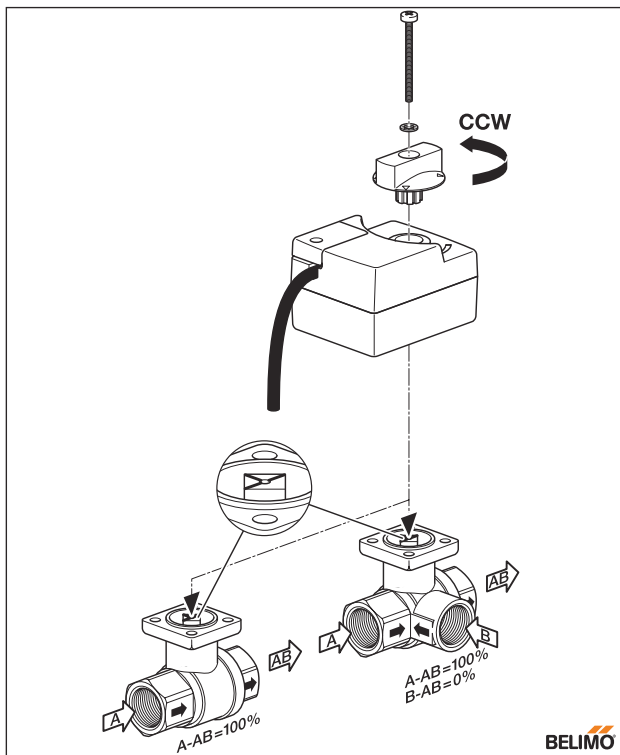

Figure 1. Valve and actuator open counter-clockwise and close clockwise. Picture shows valve and actuator in the fully open position. Also shown is the allowed direction of the liquid flow.

NOTE: The valve and actuator must be in the same position when connected. When the valve is in open position, the actuator is turned counter-clockwise before connecting, and when the valve is closed, the actuator is turned cw before connecting. The Figure 1 shows the valve and markings on valve spindle in valve open (cooling/heating on max) position.

5. Prepare / connect wiring between the ventilation unit, the geothermal pump and the actuator.

Option 2:

A separate pump is used for circulating brine in the supply air coil.

The delivery includes

- a relay for starting up the circulation pump for the ventilation unit's cooling coil. The relay is situated on the unit motherboard, connection DO3.
- a 3-way control valve (Belimo R3..) needed for cooling and
- the actuator (Belimo TR24-SR).

Temperature is controlled using the ventilation unit's own automatic control. The ventilation unit controls the circulation pump and the 3-way valve.

The heat pump will not be started up for ventilation cooling.

Installation:

1. Mount the cooling coil in the supply air duct (in case of a duct coil).
2. Connect the condensate water outlet.
3. Build a separate pump group with valve and actuator for circulating cool brine adjacent to the ventilation unit cooling coil. Be sure to isolate the pipes carefully with vapour proof insulation to prevent condensation on the outside of the pipes in warm and semi-warm spaces.

Follow the principal chart at the end of this manual.

NOTE: The valve and actuator must be in the same position when connected. When the valve is in open position, the actuator is turned counter-clockwise before connecting, and when the valve is closed, the actuator is turned cw before connecting. The Figure 1 shows the valve and markings on valve spindle in valve open (cooling/heating on max) position.

4. Prepare / connect wiring between the ventilation unit, the geothermal pump and the actuator, as shown in the connection diagram at the end of this manual.

Installing CHG geothermal pre-heating / pre-cooling equipment

A geothermal pre-heating / pre-cooling coil for improving the system energy efficiency can be installed in the ventilation system. A duct coil is always used when a hydronic pre-heating coil is needed. The coil is mounted in the outdoor air duct before the ventilation unit. The duct or the coil must have a filter to keep dirt out of the coil.

To avoid freezing the coil, the brine used in the coil system must meet the local rated temperature value. For example in Helsinki, the brine must still be functional at -26°C whereas in Lapland the temperature value is -38°C.

It is also possible to use earth to air heat exchangers (Earth tubes) for pre-heating or pre-cooling. The earth tube must be combined with a normal outside air duct and a damper that switches the outside air flow between the earth tube and the normal outside air duct depending on the actual need for pre-cooling

and pre-heating. The damper can be controlled from the same relay that controls the circulation pump for the hydronic pre-cooler/heater.

The CHG pre-heating / pre-cooling system can be built as a separate system (option 1) or as a part of the geothermal heat system (option 2).

Detailed principal charts are found at the end of the manual.

Option 1:

A ground loop is built for the pre-heating/cooling coil. To avoid freezing of the system, brine in the loop must meet the local rated temperature value. The ventilation unit automatic control regulates the system's temperature. The ventilation unit controls the circulation pump and the 3-way valve.

Installation:

1. Mount the cooling/heating coil in the outside air duct.
2. Connect the condensate water outlet.
3. Build a separate pump group for circulating cool brine adjacent to the ventilation unit cooling/heating coil. Be sure to isolate the pipes carefully with vapour proof insulation to prevent condensation on the outside of the pipes in warm and semi-warm spaces.
4. Prepare / connect wiring between the ventilation unit, the circulation pump and the actuator.
5. Install and connect the outside air temperature sensor (TE01) in the outside air duct before the duct coil. Consult the electrical connection diagrams at the end of this manual.

Option 2:

A separate loop is isolated from the geothermal pump brine loop for the cooling coil. To avoid freezing the coil, brine in the loop must meet the local rated temperature value. In addition to this, a heat exchanger is installed in the coil system to ensure the functionality of the geothermal pump. For the pre-heating / pre-cooling coil to yield any benefits, there must be some flow in the collector ground loop of the geothermal pump. Temperature is controlled using the ventilation unit's own automatic control. The ventilation unit controls the circulation pump and the 3-way valve.

Installation:

1. Mount the cooling / heating coil in the outside air duct.

2. Connect the condensate water outlet.
3. Build a separate pump group for circulating cool brine adjacent to the ventilation unit cooling coil. Be sure to isolate the pipes carefully with vapour proof insulation to prevent condensation on the outside of the pipes in warm and semi-warm spaces.
4. A heat exchanger is installed in the coil system.
5. Install and connect the outside air temperature sensor (TE01) in the outside air duct before the duct coil. Consult the electrical connection diagrams at the end of this manual.
6. Prepare / connect wiring between the ventilation unit, the geothermal pump and the actuator.

Requirements and preparations for electrical connections



NOTE: Only an authorized electrician is allowed to perform electrical work on the ventilation units.

Refer to the electrical drawings at the back of this manual.

Preparatory electrical work

Before you start the installation, make sure that:

- Appropriate power supply is available for the ventilation unit.
- Higher than 30mA fault current is provided. Because of this, no other electrical appliances should be plugged into the same outlet.
- An internet connection is provided, if the user wants to access the eAir panel network interface.
- Wall mount of the eAir panel is installed on a wall junction box. Do not keep the eAir wall mounting bracket uninstalled while using the eAir panel. If You accidentally contact the circuit board behind the wall mounting bracket with your hand or any conductive object, you can damage the wall mounting bracket.
- Cabling between the unit and the control panel wall mount. The cable must run inside a protective conduit of at least Ø 20 mm. The cable included in the basic delivery is 10 m. Optionally, a 30 m cable is available. The cable heads are type RJ4P4C.

External sensors:

Some external sensors might need to be installed depending on model of ventilation unit.

- The sensor element for duct mounted temperature, RH and CO2 sensors is to be mounted inside the duct. Most temperature sensors are supplied with a ready made 5 m long cable. RH and CO2 sensors need wiring on site.
- The place for the sensor is chosen according to the unit of measurement that is to be measured. Consult the control diagram at the end of this manual. The placement in the duct is chosen at a straight segment, at least 2x the duct Ø before and after any duct coil, bends or fittings.
- A suitable hole for the sensor and a rubber grommet is drilled in the duct.
- Sensors attached to a cable is pushed through the rubber grommet so that the sensor element is a few centimetres inside the duct. The rubber grommet must be air tight, and tight enough that the sensor cable cannot slip through by itself. A cable tie is recommended to lock the sensor in place.
- Sensors with rigid pipe type sensor elements, are mounted through an adjustable flange, that is mounted to the duct. The sensor element is pushed through the flange and locked in place with a screw at a suitable depth.
- Electrical connections are done according to the electrical schematics at the end of the manual.

Preparing eAir control panel wall mounting bracket

The eAir control panel needs to be installed on a wall junction box. One ventilation unit can be controlled with the maximum of 2 panels. The panels can have their own wall mounting brackets, or both panels can be linked to the same wall mounting bracket. If the panels have a shared holder, the other panel needs a separate micro USB charger (not supplied by Ensto Enervent).

Commissioning two control panels with their own wall mounting brackets

If the ventilation unit is controlled with two control panels with their own wall mounting brackets, the panels must be given different addresses. The address is chosen on the controller card on the back of the wall mounting bracket. One of the wall mounting brackets will get the address "1" and the other the address "2". We recommend that the address is marked both on

the wall mounting bracket and on the control panel, so the residents know which panel belongs in which wall mounting bracket.

Commissioning two control panels with shared wall mounting bracket

If the ventilation unit is controlled with two control panels with a shared wall mounting bracket, the additional panel must be linked to the wall mounting bracket. To do that, slide the DIP sliding switch "2" down and up again. Check the electrical connection diagram on page 85. The linking mode is activated if a yellow LED light starts flashing on the controller card. The linking mode is active for 10 minutes. Momentarily place the eAir operating panel in the wall mounting bracket, for the panel to start up. The panel will show that it is trying to connect to the network. Press *Re-connect the radio* > *Reset*. Now the control panel will connect to the wall mounting bracket.

Connecting room temperature sensor to wall mounting bracket (additional equipment)

In order to run the unit on room temperature regulation, a room temperature sensor must be connected. The room temperature sensor is connected to the controller card on the back of the wall mounting bracket. If you install two wall mounting brackets with room temperature sensor, the sensor TE20 is connected to the wall mounting bracket "1" and TE21 connected to the wall mounting bracket "2".



NOTE: You need to go through the set-up wizard only in one of the panels. Connect the power to the other panel when you are ready with the wizard. The panel will fetch the updated data from the motherboard.

The functions and accessories listed in the following table may need external wiring or connecting to function:

	Location on MD controller card	Voltage/current	Cable (example)	Wiring outside AHU
AI NTC				
TE20 /TE21 Room temperature sensor	Connector on eAir operating panel wall holder circuit board	3,3VDC	KLM 2X0.8	Yes
TE01 Outside air temperature	X1	3,3VDC	Quick connector 5m cable supplied with AHU	Yes, if preheater/ precooler (CHG)
TE10 Supply air temperature	X3	3,3VDC	Quick connector 5m cable supplied with AHU	Yes, if duct heater/ cooler coil
TE62 Supply coil liquid pipe (MDX)	X5	3,3VDC	Quick connector 5m cable supplied with AHU	Yes, if DX duct coil TE62 (MDX)
TE45 Heating coil return water temperature	X12	3,3VDC	Quick connector 5m cable supplied with AHU	Yes, if duct heater coil
Digital outputs DO		Potential free contact		
ON/OFF Control for heating	DO2	Max 250VAC/50VDC 8A/2A inductive load	MMJ 3x1,5	Yes, if hydronic heating
ON/OFF Control for cooling / ON/OFF control for heating (MDX)	DO3	Max 250VAC/50VDC 8A/2A inductive load	MMJ 3x1,5	Yes, except HP and CO
ON/OFF Control for dampers	DO5	Max 250VAC/50VDC 8A/2A inductive load	MMJ 3x1,5	Yes
ON/OFF Control for preheating / ON/OFF Control for precooling (CHG) / ON/OFF Control for heating circulating pump (Aqua KIW)	DO6	Max 250VAC/50VDC 8A/2A inductive load	MMJ 3x1,5	Yes, except Twin Tropic or built in preheater coil
Timer controlled relay / ON/OFF Control for circulating pump PU80 (Aqua) / ON/OFF control for extract air cooling (TCG)	DO7	Max 250VAC/50VDC 8A/2A inductive load	MMJ 3x1,5	Yes
A/AB alarm output NO	DO8	Max 250VAC/50VDC 8A/2A inductive load	KLM 2x0.8	Yes
Analog inputs AI				
%RH1	AI1 (user configurable)	0-10VDC	KLM 4x0.8	Yes
%RH2 / Boiler temperature TE80 (Aqua)	AI2 (user configurable)	0-10VDC	KLM 4x0.8	Yes
Free / PDE10 supply air duct pressure	AI3 (user configurable)	0-10VDC	KLM 4x0.8	Yes
Free / PDE30 extract air duct pressure	AI4 (user configurable)	0-10VDC	KLM 4x0.8	Yes
CO2/1	AI5 (user configurable)	0-10VDC	KLM 4x0.8	Yes
CO2/2	AI6 (user configurable)	0-10VDC	KLM 4x0.8	Yes
RH10 Supply air relative humidity sensor (Dehum/Twin Tropic/TCG)	AI11 (sw configurable)	0-10VDC	KLM 4x0.8	Yes, if duct coil
TE10 Supply air temperature (Dehum/Twin Tropic/TCG)	AI12 (sw configurable)	0-10VDC	KLM 4x0.8	Yes, if duct coil

	Location on MD controller card	Voltage/current	Cable (example)	Wiring outside AHU
Free	AI13 (sw configurable)	0-10VDC	KLM 4x0.8	
Free	AI14 (sw configurable)	0-10VDC	KLM 4x0.8	
Free	AI15 (sw configurable)	0-10VDC	KLM 4x0.8	
Free	AI16 (sw configurable)	0-10VDC	KLM 4x0.8	
Analog Outputs AO				
Control voltage for cooling / Control voltage for additional after heater (MDX-E/HP-E/HP-W)	AO3	0-10VDC 10mA	KLM 2x0.8	Yes, except built in heater
Control voltage for heating / Control voltage for compressor power (MDX/HP)	AO5	0-10VDC 10mA	KLM 2x0.8	Yes, if MDX or hydronic heating
Control voltage for preheater / Control voltage for precooler (CHG) / Control voltage for HRW #2 (Twin Tropic)	AO6	0-10VDC 10mA	KLM 2x0.8	Yes, CHG
Control voltage for extract air preheater (HP) / Control voltage for extract air dehumidification (TCG) / Control voltage for HRC defrosting (WGHR)	AO7	0-10VDC 10mA	KLM 2x0.8	Yes, if duct heater
Control voltage for hot water production	AO8	0-10VDC 10mA	KLM 2x0.8	Yes
Digital inputs DI		Connected to potential free NO contact		
Emergency stop	DI1 (fixed)	24VDC	KLM 2x0.8	Yes
PDS10 supply fan pressure switch / Defrosting indication (MDX/HP)	DI2 (user configurable)	24VDC	KLM 2x0.8	Yes, MDX
Additional time (office mode only)	DI3 (user configurable)	24VDC	KLM 2x0.8	Yes
Manual boost	DI4 (user configurable)	24VDC	KLM 2x0.8	Yes
Away mode	DI5 (user configurable)	24VDC	KLM 2x0.8	Yes
Overpressure	DI6 (user configurable)	24VDC	KLM 2x0.8	Yes
Central vacuum cleaner indication	DI7 (user configurable)	24VDC	KLM 2x0.8	Yes
Cooker hood indication	DI8 (user configurable)	24VDC	KLM 2x0.8	Yes
Electrical after heater alarm / Compressor fault (MDX/HP)	DI10 (fixed)	24VDC	KLM 2x0.8	Yes, if MDX
Miscellaneous connections				
Operating panel connectors	X27, X28		10m cable supplied with AHU	Yes
Modbus-RTU	X26		Instrumentation cable 2x2x0.5	Yes
Ethernet	X19		Cat5	Yes
O3 Ozone sensor (ION)	Connector 11 on ICEA2000A unit	0-10VDC	KLM 4x0.8	Yes

For more information on electrical connections, see the control and connection diagrams at the end of this manual.

The ventilation unit can also be connected via Modbus, connector X26. Specification of Modbus:

- Modbus address 1 (default)
- Communication standard RS485
- Modbus traffic via Modbus connector X26 of controller card
- Speed 9600, 19200 or 115200 bps
- 8 bit
- No parity or parity

The order of Freeway connector's pins is marked on the controller card.

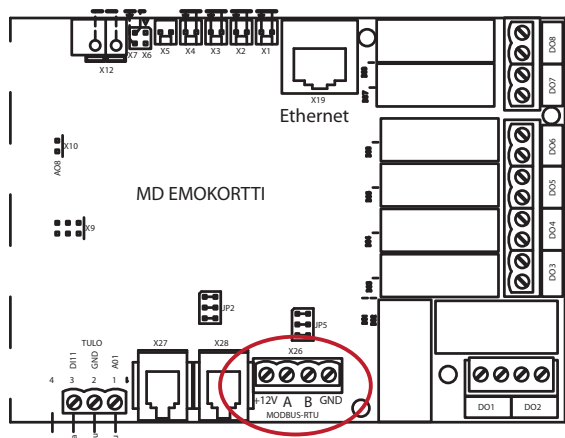

Modbus registers are available on Ensto Enervent webpage www.enervent.fi



WARNING: Do not connect the external bus to the motherboard before the bus is programmed and compatible with the unit control parameters.

Installation



NOTE: Before you install the ventilation unit, make sure there are no foreign objects in the ventilation unit and duct system.

- Refer to the model-specific dimensional drawings in the back of this manual for your specific ventilation unit type.
- Make sure to check the order of duct connections to avoid crossed connections.
- Do not start the ventilation unit although it is installed until the building is taken into use.

- If the ventilation unit is started too early, the ventilation system will be contaminated by building dust.
- The ventilation unit duct connections are the same size as the duct. Use a circular duct fitting to connect the unit to the duct.
- Remember to insulate the duct all the way to the unit casing.

Additional materials needed for installation

Material	Description of use
Screws	For hanging the rear attachment bracket and ventilation unit on the wall (if applicable). Select the screws according to the wall material.
Sheet metal screws	For attaching the rear attachment bracket onto the ventilation unit.
Wall junction box	For installing eAir wall mount.
Cables	As specified in chapter <i>Preparatory electrical work</i>
Duct tape	For sealing.
Insulation sheets (soft foamed plastic)	For preventing structure-borne noise.
Insulation material (foamed plastic and/or wool, depending on where the unit will be installed)	For heat and sound insulation.
Rivets	For attaching the ventilation ducts onto the unit.
Spirit level	For making sure that the unit is level.
Water pipe	For connecting duct coils and for disposing of condensate water.
Watertrap	For condensate water drain.
Reducing fittings for duct connections	For fitting the ducts in the ventilation system. NOTE: Always use reducing fittings, if necessary.
Dampers	To keep cold air out.
Silencers	To reduce possible noise.
Suitable grommets for duct mounted sensors	For mounting sensors in the ducts.
Shut-off valves	To facilitate servicing of unit.
Hydronic balancing valves	To adjust for proper water flow.

Installing models Pinion, Pingvin, Pingvin XL, Pandion, Pelican, Pegasos, Pegasos Twin Tropic and Pallas

Wall installation

For models Pinion, Pingvin, Pingvin XL and Pandion

1. Prepare the holes in the wall.
2. Bring in the ducts through the cross cut in the vapor barrier to the height to which the unit will be mounted.
3. Seal the vapor barrier pass-through using for example duct tape.
4. Install an insulating plate at the back of the ventilation unit or otherwise prevent the structure-borne noise. Soft foamed plastic sheets are recommended (not included in the delivery).
5. Install an extra layer of insulation outside the ventilation unit (for example foamed plastic), if the unit is installed with its side against exterior wall or if there is any other reason to suspect that the outside of the unit will condense. Condensation risk is present in areas where the climate is cold.
6. Installation varies for different models:

6a. For models Pingvin, Pingvin XL and Pandion:

- Install the rear attachment bracket at the desired height.
- Lift the unit on the bracket.



NOTE: Remove the heat exchanger before you lift the unit. This will make the unit much lighter to handle. Remember also to remove or secure the doors so that they won't open during lifting.

- Attach the unit to the wall by the upper mounting lugs.
- Don't forget the rubber bushings for the fastening screws. (Pingvin and Pandion only).
- Attach the rear attachment bracket to the unit's base using sheet metal screws.



NOTE FOR PINGVIN: It is essential for the proper disposal of condensate water that a Pingvin unit is installed slightly tilted backwards. This must be verified using a spirit level.

- Make sure the ventilation ducts are insulated according to the instructions in Insulating ventilation ducts chapter
- Make the applicable electrical and plumbing connections according to the electrical and principal diagram at the end of this manual.

6b. For model Pinion:

- Lift the unit on the wall at the desired height and attach it to the wall by the upper mounting lugs.
7. Connect the ducts to the duct connections on the unit.
 8. Connect the drain for disposing of condensate water.
For more information, see chapter *Draining condensate water*.
 9. Make sure you have insulated the ducts all the way to the ventilation unit frame.
 10. Make the applicable electrical and plumbing connections according to the electrical and principal diagram at the end of this manual.

Ceiling installation

Ceiling installation for models Pingvin and Pandion

Dimensional drawings for each of the models can be found at the end of this manual.

1. Install the supplied duct couplings and insulation rings on top of the unit.
2. Unscrew the cover of the electrical cabinet.

Prepare the cable lead-ins on unit for the cables coming through the ceiling.

Leave the electrical cabinet cover open.

3. Guide the unit power cable to run in front of the hook to keep the cables from squashing between the unit and the ceiling installation plate.



NOTE: Remove the heat exchanger before you lift the unit. This will make the unit much lighter to handle. Remember also to remove or secure the doors so that they won't open during lifting.

4. Make sure there is enough space underneath the ceiling plate to fit the unit.
5. Lift the unit up.
6. Hook the unit to the front side of ceiling installation plate.
7. Connect the cable(s) coming through the ceiling plate to the electrical enclosure box.
8. **Make sure the unit is hanging straight, directly in the middle of the ceiling plate.**
9. Push the base of the unit upwards until it locks onto the ceiling plate.
10. Secure the unit in place by tightening the two security screws on both sides of the ceiling plate.

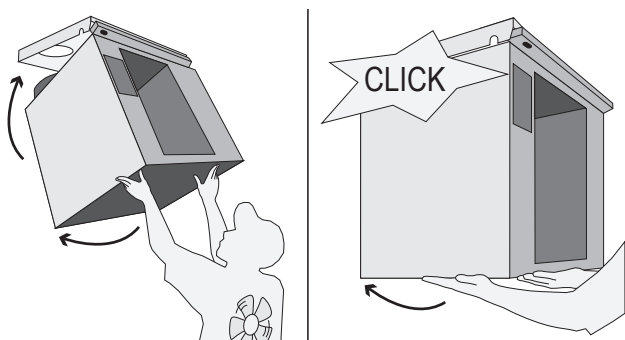
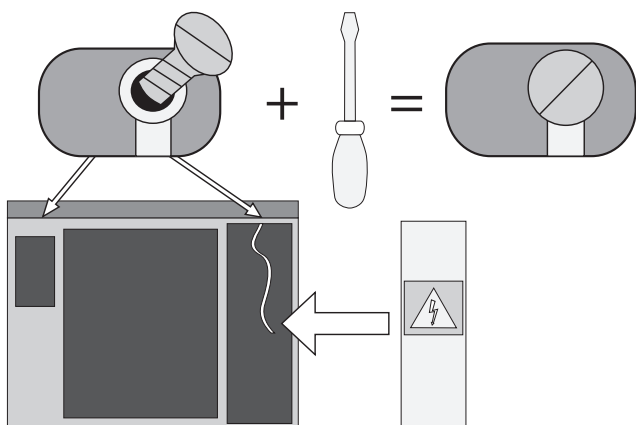

The installation is secure even with just the locking system of the ceiling plate. The security screws are an added security measure.

11. Put the heat exchanger back in the unit and close the electrical cabinet door. Put the doors back if you removed them before the lifting.
12. Make the applicable electrical and plumbing connections including the condensation drain according to the electrical and principal diagram at the end of this manual.



NOTE: Make sure to leave the cables loose in case the unit needs to be taken down for some reason.



NOTE FOR PINGVIN: It is essential for the proper disposal of condensate water that a Pingvin unit is installed slightly tilted backwards. The Pingvin unit is automatically installed tilted in the ceiling installation plate.

Taking down ceiling installed unit



WARNING: Make sure you are holding the unit in its place when opening the locking plates. When the locking plates are opened, the unit's back side will disengage from the ceiling plate. Make sure you have enough space under the unit for it to swing down.

1. Disconnect the power supply.
2. Open the security screws.
3. Open the electrical cabinet and disconnect the cables coming from the ceiling.
4. Holding the unit securely in its place, twist both of the locking plates open (towards yourself) using a screwdriver.
5. Lift down the unit.

Ceiling installation for models Pinion and Pingvin XL

Before installing the ventilation unit, make sure that the insulation rings for the duct connections and the plastic spacers for the attaching screws are in place.

Pingvin XL is attached to the ceiling installation plate from the inside of the unit.

Pinion ventilation unit is attached to the ceiling installation plate with two screws under the unit.

1. **Pinion:** Remove the fans and heat exchanger.
Pingvin XL: Remove the heat exchanger, extract fan and extract filter

To make the unit lighter to handle, we recommend that you remove these components before lifting the unit up to hang from the attaching hook.

2. Attach the ventilation unit onto the ceiling plate using the screws included in the delivery.
3. Tighten the screws in turns so that the unit sets in place evenly.

The tightening torque is max 5 Nm.

4. Make sure that the electricity supply cable is not pinned between the ceiling installation plate and the ventilation unit.
5. Reinstall the fan, filter and heat exchanger.
6. Make the applicable electrical and plumbing connections including the condensation drain according to the electrical and principal diagram at the end of this manual.

Floor installation

For models Pandion, Pelican, Pegasos, Pegasos Twin Tropic and Pallas

Dimensional drawings for each of the models can be found at the end of this manual.

1. Set the ventilation unit on the floor or on a platform standing on its own rubber feet.
2. Make sure there is at least a 10 mm gap all around the unit. If the unit is installed with its side against a wall, a 15 mm gap is required so the door can be fully opened.
3. Note the space needed for disposing of condensate water and the water trap under the unit (if applicable).
4. Make sure there is at least 95 cm (Pallas 130 cm) of space in front of the unit's maintenance hatch and that the electrical connections can be easily accessed.
5. Connect the unit to a condensate water disposal drain with watertrap.
6. Connect the ducts to the ventilation unit using rivets. Insulate the ducts according to the instructions in Insulating ventilation ducts section. Note that the Pegasos Twin Tropic unit duct connections are different than the normal Pegasos unit duct connections.
7. Make the applicable electrical and plumbing connections according to the electrical and principal diagram at the end of this manual.

Installing models LTR-2, LTR-3, LTR-4, LTR-6 and LTR-7

Dimensional drawings for each of the models can be found at the end of this manual.

If installation space temperature may drop below +5°C, isolate the ventilation unit with insulation equaling 100 mm wool. If you are using solid (hard) insula-

tion, avoid fastening the isolation in a way that conducts sound and vibration to the house frame.

1. Set the unit on top of an insulating plate, for example a chipboard covered with 100 mm of hard insulating wool – above the rafters in the attic or on a separate shelf in a storage etc.
2. Note the space needed for disposal of condensate water and the water trap.
3. Make sure there is enough space left in front of or above the maintenance hatch:
 - LTR-2 and LTR-3 min. 50 cm
 - LTR-4 and LTR-6 min 60 cm
 - LTR-7 min 70 cm
4. Note the space needed for opening the maintenance hatch locks.
5. Make sure the electrical connections can be easily accessed.
6. Connect the ducts to the ventilation unit using rivets. Insulate the ducts according to the instructions in Insulating ventilation ducts section.
7. Connect the unit to a condensate water disposal drain with watertrap. If the ventilation unit is equipped with a built in cooling coil it is recommended to install the unit with the service hatch to the side to enable the condensate water to drain more easily. LTR-4 units with cooling coil has two optional 32 mm condensation drains. One drain is welded shut and one is ready to use. Depending on the way the LTR-4 unit is installed, the drain that becomes lower is to be used. If the lower drain is the welded one, a short piece of the pipe is sawed off to open the pipe, and the water trap is connected to the pipe. The unused condensation drain must be plugged!
8. Make the applicable electrical and plumbing connections according to the electrical and principal diagram at the end of this manual.

Draining condensate water

All Enervent ventilation LTR units must be drained. When air cools down (condenses), condensate water forms. For example in winter time when humid inside air meets the cold heat recovery wheel, or when warm outside air meets the cooling coil in the ventilation unit (if applicable).



WARNING: The condensate water drain must not be directly connected to a sewer pipe!

- The condensate water should be led in a falling, at least Ø15 mm pipe, through a watertrap to a floor drain or such.
- The pipe must at all times lie lower than the condensate water drip pan of the ventilation unit.
- There must not be any longer horizontal sections on the pipe.
- The condensation drain pipe must be insulated if mounted in spaces where freezing can occur.
- Only one water lock is allowed for each condensate water drain.
- If the unit is equipped with more than one condensate water drains, each one must have a water lock of its own.
- There is under pressure in the ventilation unit. We recommend a height difference of (A) 75 mm, or at least the under pressure divided with 10 in millimeters (i.e. 500 Pa under pressure -> 50 mm), between the unit drain and the water lock drain.
- We recommend that the height of backwater in the water lock (B) is 50 mm, or at least the under pressure divided with 20 in millimeters (i.e. 500 Pa under pressure -> 25 mm height of backwater). The above also applies to duct coils for cooling mounted in the outside air duct or extract air duct.
- There are over pressure inside duct coils mounted in the supply air duct. We recommend the height difference (A) between the duct coil drain and the water lock drain is 25 mm. The water lock height of backwater (B) must be 75 mm, or at least the over pressure divided with 10 in millimeters (i.e. 500 Pa under pressure -> 50 mm).
- The water lock must be filled with water before starting up the unit. The water lock might dry up if water is not accumulated in it. If this happens, air might get into the pipe and hinder water from entering the water lock, which might result in an irritating "bubbling" sound.
- The functionality of the water lock must be checked every year before the heating season. And also in the spring if the ventilation unit is equipped with cooling.

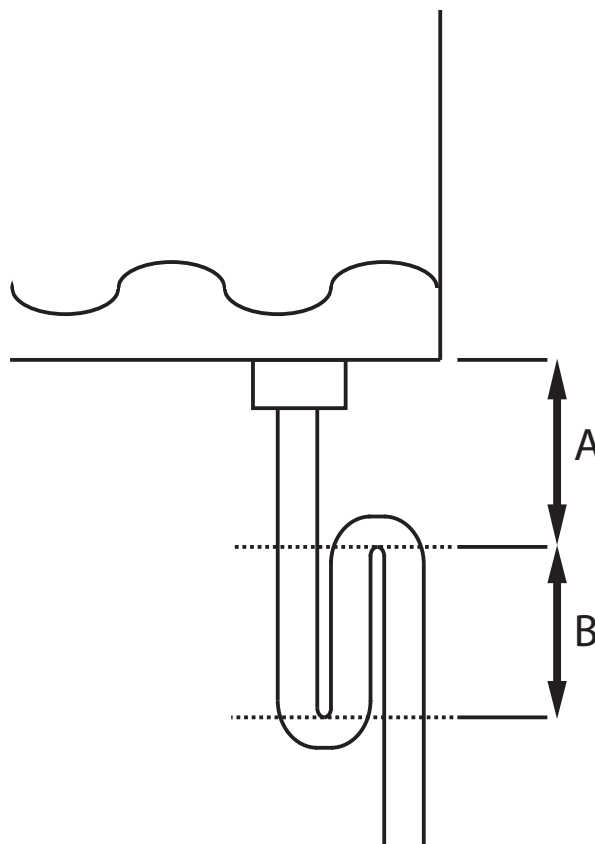

Figure 2. Condensate water pipe

Unit	1/4" (inner thread)	DN32	G1/2" (VEAB, outer thread)	DN32 (duct case)
Pinion ECE	•			
Pinion MDE/MDW	•			
Pingvin MDE/MDW	•			
Pingvin MDE-CG/MDW-CG	•		•	
Pingvin XL MDE/MDW	•			
Pingvin XL MDE-CG/MDW-CG	•		•	
Pandion MDE/MDW	••			
Pandion MDE-CG	•	•	•'	
Pandion MDW-CG	•		•	
Pandion MDX-E	•	•		
Pandion MDE-TCG/MDW-TCG		••		
Pelican MDE/MDW	••			
Pelican MDE-CG/MDW-CG	•	•	•'	
Pelican MDX-E	•	•		

Unit	1/4" (inner thread)	DN32	G½" (VEAB, outer thread)	DN32 (duct case)
Pelican HP / HP Oceanic		••		
Pegasos MDE/MDW	••			
Pegasos MDE-CG/MDW-CG	•	•		
Pegasos MDE-CO/MDW-CO		••		
Pegasos MDX-E	•	•		
Pegasos XL MDE/MDW	••			
Pegasos XL MDE-CG/MDW-CG	••		•	
Pegasos XL MDE-CO/MDW-CO		••		
Pegasos XL MDX-E	••			•
Pegasos HP / Aqua		••		
Pegasos Twin Tropic		••		
Pallas all models		••		
LTR-2 MDE/MDW	••			
LTR-2 MDE-CG/MDW-CG	••		•	
LTR-3 MDE/MDW	••			
LTR-3 MDE-CG/MDW-CG	••		•	
LTR-3 MDX-E	••			•
LTR-4 MDE/MDW	••			
LTR-4 MDE-CG/MDW-CG	••	••	•'	
LTR-4 MDX-E	••	••		
LTR-6 MDE/MDW	••			
LTR-6 MDE-CG/MDW-CG	••	•	•'	
LTR-6 MDX-E	••	•		
LTR-7 MDE/MDW	••			
LTR-7 MDE-CG/MDW-CG	••		•	
LTR-7 MDX-E	••			•
LTR-7 XL MDE/MDW	••			
LTR-7 XL MDE-CG/MDW-CG	••		•	
LTR-7 XL MDX-E	••			•

- condense drain
- two condense drains of the same size
- ' option

Further installation phases: models MD and MDE

Principal, control and wiring diagrams for each model can be found at the end of this manual.

1. Connect the external cables such as the cable between the unit and the control panel holder and any external sensors. Do not connect Modbus until all installation and commissioning work is done.
See chapter Requirements and preparations for electrical connections.
2. Install over voltage protection to the main power supply.
See the table of technical features at the end of this manual.
3. Open the unit's maintenance hatch and make sure that the unit is clean from the inside, that there are no unwanted objects inside and that the filters are in place.
4. Close the hatch carefully.

Installing model MDW

Principal, control and wiring diagrams for each model can be found at the end of this manual.

Check the principal charts for units with fluid coil. Install and connect the water pipes according to these charts.

1. Install the dampers and damper motors.
 2. Install and connect the water pipes.
 3. Install the valve and the valve actuator.
-  **NOTE:** Do not install the actuator so that the manual control knob faces downwards.
4. Connect the water.
 - Check the water coil and its connections for leaks immediately after the system has been filled with water.
 - The water heating coil needs a steady flow of sufficiently warm water without large temperature fluctuations. Be sure to check and adjust the water flow in the heating coil according to the technical features table at the end of this manual.
 - Do not connect to a point where the water circulation ends for example during hot water production. If the water is taken for instance from a ground source heat pump, the heating coil needs its own circulation pump.

- If the installation is done in wintertime it is recommended not to let water in the coil until the ventilation is running. This in order to prevent cold air from entering the ventilation system and possibly freezing the coil.
5. Connect the external cables such as the cable between the unit and the control panel holder, external sensor(s), actuator and pump.
 - Do not connect Modbus until all installation and commissioning work is done.
 6. Install over voltage protection to the unit.
 7. Open the unit's maintenance hatch and make sure that
 - the unit is clean from the inside
 - there are no unwanted objects inside
 - the filters are in place and
 - the condensate drain works.
 8. Close the hatch carefully.
 9. Connect the unit to an appropriate electric supply.



NOTE: The valve and actuator must be in the same position when connected. When the valve is in open position, the actuator is turned counter-clockwise before connecting, and when the valve is closed, the actuator is turned cw before connecting. The Figure 3 shows the valve and markings on valve spindle in valve open (cooling/heating on max) position.

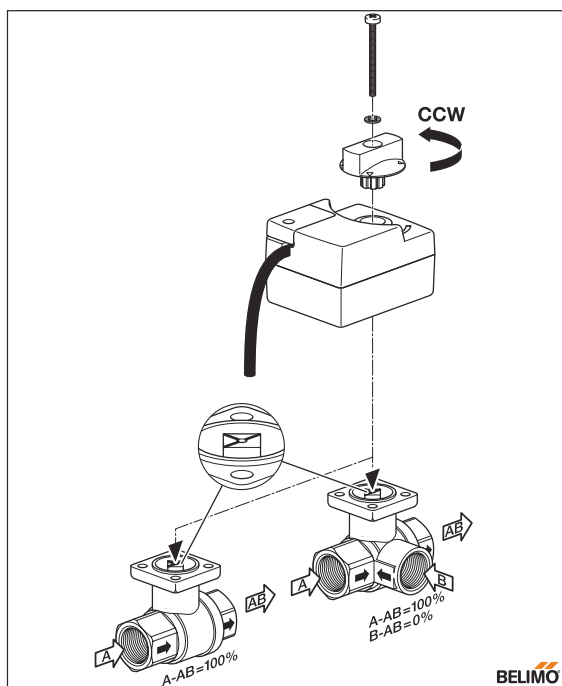

Figure 3.

Installing model CG, TCG and Twin Tropic CW

Principal, control and wiring diagrams for each of the models can be found at the end of this manual.

1. Install the unit as instructed by MD, MDE or MDW model installation instructions.

Because of the risk of freezing, the liquid circulating in CG coil cannot be just water. The liquid must contain anti-freeze agent, such as ethylene glycol or some other mixture suitable for a cooling system or the ventilation unit must be ordered with freeze protection for the cooling coil(s), if the unit is installed where icing can occur.

2. Install the pipes. Be sure to isolate the pipes carefully with vapour proof insulation to prevent condensation on the outside of the pipes in warm and semi-warm spaces.
3. Install and connect the coil, control valve and valve actuator according to the chosen installation method.



NOTE: Do not install the actuator so that the manual control knob faces downwards.

For more information, see the applicable principal, control and wiring diagrams at the end of this manual.

4. Open the unit's maintenance hatch and make sure that

- the unit is clean from the inside
- there are no unwanted objects inside and that
- the filters are in place.

5. Close the hatch carefully.

Installing model ION.

Principal, control and wiring diagrams for each model can be found at the end of this manual. Refer to the ionair operating manual delivered with the ventilation unit.

1. Install the ventilation unit as instructed by the other type designations of the ventilation unit.
2. Install the ozone (O310) sensor in the supply air duct, in a straight section at least 2x the duct \varnothing after and before any duct coil, bend or other duct fitting. Connect the ozone sensor to the ICE-A2000 controller according to the electrical con-

nection schematics. Terminals 11,12 and 13 in the ICE-A2000 controller.

3. Open the 4 locking screws on the frame of the ionizer module, located below the electrical connection box of the ventilation unit, and carefully withdraw the ionizer slot-in module.
4. The ionizer tubes are delivered separately with the ventilation unit, and needs to be assembled before commissioning the ventilation unit. The ionizer tubes are made of a glass tube with an inner and outer metal mesh. Handle them with care! They are fragile!
5. Attach the ionizer tubes to the connectors of the IMK ionizer module. Turn the tubes clockwise to lock them in place, and connect the separate yellow/green earth wire to the earth terminal next to the tube. Reinstall the IMG ionizer module in the ventilation unit and tighten the locking screws.
6. Connect the electrical connector to the IMG ionizer module. Run the ventilation unit for at least 1/2h and check that there are no alarms.

Commissioning

For the ventilation unit to start running, it needs

- Minimum +8 °C return water flow temperature (if applicable)
- Supply and extract air below +55 °C

For the ventilation unit to stay running, it needs

- Minimum +15 °C measured extract air temperature
- Above +5 °C heat recovery supply air
- Above +10 °C supply air temperature.
- All foreign objects have been removed from the ventilation system

Calibrating airflow

After the unit has been switched on, its airflows must be calibrated to the planned values. The airflow calibration is performed at start-up of the ventilation unit, in the setup wizard of the eAir controller. The airflow calibration is done separately for each operating mode of the ventilation unit.

When making the calibration make sure that

- all filters are clean and
- all supply and extract air valves, the roof pass-through and the outside air grating are in place.

The outside air grating must not be provided with an insect net.

To achieve optimal values during calibration the airflows must be measured at each duct opening. A suitable measuring instrument is a thermo anemometer or differential pressure meter. With the help of registered values, airflow can be regulated to achieve the projected values.

A correctly calibrated ventilation unit is quiet and gives a good heat return and also upholds a small under-pressure in the house. The underpressure stops humidity from entering the walls and ceiling. If the ventilation unit is equipped with dehumidification functionality (Twin Tropic, TCG and CGW units) a slight overpressure in the building might be preferable, depending on the local climate conditions.

Commissioning checklist

Item	Checked	Notes
The unit has been installed in its place according to the installation instructions provided by the manufacturer.		
Condensate water disposal pipe has been connected to a water lock and tested.		
Silencers have been installed in the supply and extract air ducts.		
For models with water coils: dampers have been installed.		
All liquide coils are connected, the liquide flow(s) adjusted, and the connections are checked for leaks		
All external valves and valve actuators are connected and checked for correct operation.		

Item	Checked	Notes
For CHG model: coil, control valve, valve actuator and temperature sensor for outside air duct have been installed and connected, checked for correct operation, and the brine flow adjusted. The freezing point of the brine liquid checked to be sufficient..		
Terminal devices have been connected to the ventilation network.		
Outside air grating has been installed for fresh air intake. NOTE! Do not cover the grating with a mosquito net. It will make it very difficult to clean.		
Unit is connected with an appropriate electric supply.		
Control panel wall mounting bracket has been connected.		
All external sensors are connected and checked for correct operation.		
The ventilation ducts are insulated according to the ventilation plan.		

Control system

The ventilation unit is controlled with the built-in MD control system and it's eAir control panel. The control is configured on the factory, but needs commissioning on site.

Commissioning eAir control panel

The eAir control panel is used for setting up the ventilation system management and for using the ventilation.



WARNING: Be careful not to damage the control panel screen with a sharp or scratchy tool.

Please be patient! The control panel takes a while to react.

Installing battery

The control panel does not have the battery inside it for the delivery. You must install the battery before charging the control panel.

1. Open the battery compartment lid at the back of the control panel.
2. Remove the protective tape from the battery terminals, if present.
3. Slide the battery in place.
4. Close the battery compartment lid.



WARNING: Make sure to put the battery in the right way so as not to damage the contact pins.

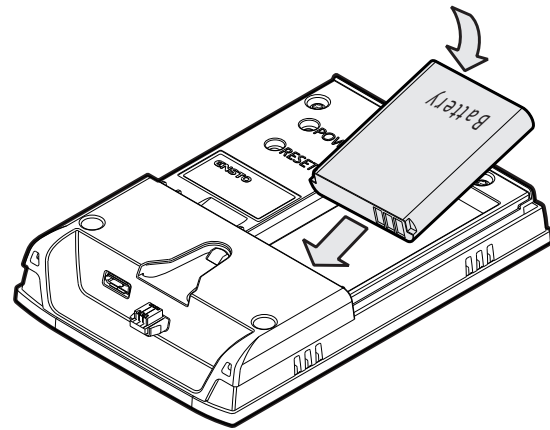

Charging control panel

1. Place the panel in the wall mounting bracket.

The battery begins charging. Charge the battery for 24 h before starting the setup wizard.



NOTE: You can also charge the control panel using a micro USB charger (not supplied by Ensto Enervent).

Important to know about control system



NOTE: The code for the *Setup wizard* and *System configuration* is **6143**.

When the ventilation unit power is switched on for the first time, a setup wizard starts automatically.

The setup wizard is developed to make it easier to take the control panel into use. The wizard goes through all the settings needed for commissioning the ventilation unit.

If you need additional help for settings, please tap the item text on the screen and a screen tip will appear.



NOTE: All the settings are defined using the setup wizard. You can view the settings in the Settings menu, but you can't make any changes to the values affecting fan speeds there.

Factory settings are basic settings that are suitable for most installations. Exception to this is, of course, fan speed settings for different operating modes, which must be specified and set separately for each installation. Otherwise, do not change the factory setting, unless otherwise specified in the ventilation system plan.

All the settings made using the wizard comes into effect immediately.

All changes are saved automatically in the non-volatile memory at the end of the wizard when using it the first time. The following times answering "Yes" to the question at the end of the wizard saves the settings in the non-volatile memory, from where the settings can be retrieved, if needed.



NOTE: You need to go through the set-up wizard only in one panel even though you have connected two panels to the ventilation unit. Connect the power to the other panel when you are ready with the wizard. The panel will ask which language you want to use and fetch the rest of the data from the ventilation unit motherboard.

Returning to setup wizard

If you do not go through the whole wizard at the first time, it will automatically start each time you switch on the power, so that you can finish defining the settings.

If you have finished the wizard but need to make changes to the settings, you can access the wizard by tapping on the navigation arrow on the main view and then selecting *Settings > Setup wizard*, where you enter the code 6143.

Setting up system with setup wizard

This steplist will guide you through the whole setup wizard.

Make sure that the installation work for the ventilation is completed before starting the setup wizard. If an external sensor is unconnected or the internal

temperature in the house is below +15 °C, the setup wizard cannot be completed. There is no provision for acknowledging alarms in the setup wizard. If there is an alarm during the setup wizard, it can be acknowledged only after the setup wizard is completed.

If you need to interrupt the settings for some reason, the control panel will automatically open the wizard the next time you switch on the ventilation unit power and you can continue with the settings.

If the eAir panel shows the acquiring network text and does not connect to the wall mounting bracket, first check the connection from the wall mounting bracket to the ventilation unit. **Do not** tap the *Reconnect* radio button. This will erase the pairing between the wall mounting bracket and the eAir panel, and the eAir panel will be unusable until a new pairing is done according to the instructions on page 15.

Make sure you have all the necessary information at hand before starting the setup. Ask for the necessary Modbus parameters from the supplier of the monitoring system that is connected to the Modbus and for network settings from the LAN network administrator (only if DHCP is not in use).



NOTE: Fan speed settings for different operating modes must be specified and set separately for each installation.

1. Turn the ventilation unit power on.
2. The panel starts up automatically and displays the Ensto logo.
3. Wait until the language selection appears.
This may take some time. Please wait patiently.
4. Select the right language and tap *Continue*.
The setup wizard opens.
5. Tap *Continue* to start the settings.
6. Set the date using the up and down arrows.
The date is displayed in a year-month-day format.
Tap *Continue* to accept.
7. Set the time using the up and down arrows.
The clock displays 24 h time.
Tap *Continue* to accept and enter Screen settings menu.

Screen settings

1. **Set the screen brightness by adjusting the value that appears when tapping the item.**



NOTE: Setting the brightness value low will increase the control panel battery life.

2. **Set the power saving sleep mode delay.**

This setting defines the time after which the screen will turn itself off to save the battery when it is not used. This value set here defines also the time after which the key lock will activate.

3. **Set on or off value for sleep mode when operating panel is placed in the wall mount.**

This setting defines whether the power saving sleep delay is on or off when the control panel is stored in the wall mount. This setting does not affect the screen locking.

4. **Set the secondary temperature in main view window by tapping the item.**

A list of possible temperature options appears.

This setting defines what kind of additional temperature you want to be displayed on the main view (top right corner). The default setting is *Outside air temperature*.

5. **Tap OK to accept.**
6. **Tap Continue to accept the Screen settings and to enter the Operating configuration.**

Operating configuration

1. **Set the operating environment for the Use of the unit by toggling between the environments.**

The options are *Home* or *Office*. In the *Office* mode, the unit can be switched on only by using the timer.

2. **Set the temperature control value by toggling the value name.**

The options are: *Extract air*, *Room temperature average* and *Supply air*.

- *Supply air* maintains the supply air temperature at the value specified on the main view. This is the default setting for units with no cooling functionality.
- *Room temperature average* or *Extract air* compare the temperature setting in the main view with the room temperature or extract air temperature and heat or cool the supply air accordingly. Note that these settings allow the supply air tempera-

ture to vary between +13 °C and +40 °C (factory setting). These two settings are available only for units with cooling functionality.

- *Room temperature average* setting uses the room temperature sensor for comparing (not included in the basic delivery). To be able to use room temperature control, at least one room temperature sensor must be selected in paragraph 12 or 13.

- *Extract air* is the default setting for units with cooling functionality.

3. **Set cooling on or off by toggling the value.**

This setting is available only for units with cooling functionality and does not affect cool recovery or summer night cooling.

4. **Set the outside temperature limit for cooling by tapping the temperature value and entering a new one.**

When the outside temperature is below the set value, no active cooling is allowed. The default value is +17°C.

This setting is available only for units with cooling functionality and does not affect cool recovery or summer night cooling.

5. **Set heating on or off by toggling the value.**

This setting does not affect the heat recovery.

6. **Set the outside temperature limit for heating by tapping the temperature value and entering a new one.**

When the outside temperature is above the set value, no heating is allowed. The default value is +25°C.

This setting does not affect the heat recovery.

7. **Set the minimum temperature of supply air by tapping the temperature value and entering a new one.**

This is the minimum temperature for the supply air when the temperature control value is *Extract air* or *Room temperature average*. If the supply air temperature drops below this value, the heating power is increased or cooling power decreased. The default value is +13°C.

8. **Set the maximum temperature of supply air by tapping the temperature value and entering a new one.**

This is the maximum temperature for the supply air when the temperature control value is *Extract air* or *Room temperature average*. If the supply air

temperature exceeds this value, cooling power is increased or heating power is reduced. The default value is +40°C.

9. **Set heating/cooling limitation on or off by toggling this value.**

This setting is used if the user wants to prevent continuous switching between heating or cooling when the temperature setpoint is very close to the extract air (or room temperature average) temperature. When this setting is on, larger temperature fluctuations are allowed.

10. **Set the heating limitation temperature by tapping the temperature.**

When the extract air (or the room temperature average, in room temperature mode) temperature drops, the heating is not activated until this temperature is reached.

11. **Set the cooling limitation temperature by tapping the temperature.**

When the extract air (or the room temperature average, in room temperature mode) increases, the cooling is not activated until this temperature is reached.

12. **Include the room temperature sensor(s) TE20 and/or TE21 (not included in the basic delivery) in the temperature control by toggling them on or off.**

If both sensors are selected here, the temperature control uses the mean temperature of the room sensors. If you have installed only one wall mounting bracket with room temperature sensor, it is TE20.

13. **Include the room temperature sensor(s) 1, 2 and/or 3 (not included in the basic delivery) in the temperature control by toggling them on or off.**

These sensors are room temperature transmitters that are connected to the ventilation unit. The sensors can be included or left out of the mean room temperature measuring by setting them on or off.

14. **Tap Continue to accept the Operating configuration and to enter the AI settings.**

AI settings

Define the functionality and set the voltage for the analog inputs 1-6 on the MD motherboard. AI settings needs to be configured if there are external sensors

connected to the ventilation unit, besides the two RH% and CO₂ sensors that are preconfigured.

1. Tap the desired analog input to configure the settings for that input.
 - Tap the *Function* to select the desired function for the sensor connected to the analog input.
 - Tap the *Voltage for the low voltage* to set the minimum output voltage for the connected sensor, usually 0V.
 - Tap the *Voltage for the high voltage* to set the maximum output voltage for the connected sensor, usually 10V.
 - Tap the *Low voltage effect reading*, and set the measurement reading associated with the sensor minimum output voltage, usually 0.
 - Tap the *High voltage effect reading*, and set the measurement reading associated with the sensor maximum output voltage.
 - The measured input voltage and calculated value are informative values only, and shows the real time sensor output voltage and the calculated measurement value.
2. Accept the *Settings* for the analog input by tapping the upper left arrow.
3. Tap *Continue* to accept the AI settings and to enter the *Constant duct pressure* settings.

Constant duct pressure settings

Constant duct pressure settings are set when separate duct pressure control over the ventilation unit is wanted. In order to enable constant duct pressure control, separate duct pressure transmitters must be installed and configured in the AI settings.

If constant duct pressure control over the unit is not needed, you can skip this menu.

1. **Tap Constant duct pressure control to activate constant duct pressure.**
2. **Change the value to ON.**
3. **Tap the airflow setup mode to select the mode for airflow measurements.**

Selecting *Constant pressure* (factory setting) requires all fan power settings to be entered as duct pressures, and the automation will automatically maintain the duct pressure by varying the fan speeds. Select this setting if you know the required duct pressures for the different operating modes.



NOTE: If the set duct pressure is outside the operational range of the fans, there will be a duct pressure alarm and the fans will be shut down. You will have to complete the setup wizard in order to acknowledge the alarm, and restart the fans. After which you will have to reenter the setup wizard and complete the settings.

Selecting *Constant speed* will allow the airflow measurements to be made without the duct pressure control. The measured duct pressures are shown under the fan speed settings for reference, and are automatically stored when continuing to the next setting. After completing all fan speed settings the constant duct pressure control is automatically activated, and fan speed control will be automatic according to duct pressures. Use this setting if you don't know the needed duct pressures for the different operating modes.

4. **Set P-band by tapping the item.**

P-band value determines how much the fan speed will be altered. The higher the value, the greater the change in speed. The factory setting is 25 Pa. The control is proportional.

5. **Set I-time by tapping the item.**

I-time value determines how quick the change to the fan speed will be. The higher the value, the slower the change. The default value is 5 seconds.

6. **Set DZ by tapping the item.**

DZ (dead zone) is the deviation in the set duct pressure where the controller has no effect on the fan speed. The default setting is 2 Pa.

7. **Set the Supply air duct pressure deviation alarm delay.**

If pressure deviation is greater than the set alarm limit, an alarm will be triggered after the delay set here. The default setting is 200 seconds.

8. **Set the Extract air duct pressure deviation alarm delay.**

If pressure deviation is greater than the set alarm limit, an alarm will be triggered after the delay set here. The default setting is 200 seconds.

9. **Set the Alarm limit.**

An alarm is triggered if pressure deviation is greater than the alarm limit set here. The default setting is 10 Pa.

10. **Tap Continue to accept the Constant duct pressure settings and to enter the Heat recovery settings.**

Heat recovery settings

1. **Set defrosting on or off by toggling the value.**

Enable or disable defrosting. The function is active during winter season, if enabled. When defrosting is active, the supply air fan stops and the extract air fan runs at a set speed. Activation of defrosting depends on the exhaust air temperature.

2. **Set the limit temperature for winter boost by tapping the temperature value and entering a new one.**

When the outside temperature is below this value, the heat recovery is always on 100%. The supply air temperature will not drop lower than what is received from heat recovery. The default value is +8°C.

3. **Set the Arctic mode on or off by toggling the value.**

Arctic mode is a defrosting mode that takes the outside air temperature and the absolute humidity of the extract air into account when determining the need for defrosting.

4. **Tap Continue to accept the Heat recovery settings and to enter the Operating modes settings.**

Operating modes

1. **Tap Continue to proceed from the main page to Home mode settings.**



NOTE: Fan speed settings for different operating modes must be specified and set separately for each installation. The ventilation unit fans run on the speed you are setting during setup wizard.

2. **Set the supply air fan speed for Home operating mode by tapping the percentage value and entering a new one.**

This value defines the supply air fan speed in Home operating mode. The allowed value range is 20-100%. The default value is 30%.

3. **Set the extract air fan speed for Home operating mode by tapping the percentage value and entering a new one.**

This value defines the extract air fan speed in Home operating mode. The allowed value range is 20-100%. The default value is 30%.

4. **Tap Continue to accept the Home mode settings and to enter the Summer night cooling settings.**

Summer night cooling

Summer night cooling boosts the fan speed to increase cooling when the outside air is cooler than the room air. Summer night cooling is available also for units without cooling functionality. When summer night cooling is on, active heating/cooling is not allowed.

1. **Set summer night cooling on or off by toggling the value.**
This setting does not initiate summer night cooling but only allows it.
2. **Set the starting temperature for summer night cooling by tapping the temperature value and entering a new one.**
Summer night cooling starts when the temperature of extract air exceeds this temperature value. The default value is +25°C.
3. **Set the stopping temperature for summer night cooling by tapping the temperature value and entering a new one.**
Summer night cooling stops when the temperature of extract air drops below this temperature value. The default value is +21°C.
4. **Set the lowest outside temperature limit for summer night cooling by tapping the temperature value and entering a new one.**
The temperature of outside air must be higher than this value for the summer night cooling to start. The default value is +10°C.
5. **Set the minimum temperature difference between outside air and extract air for summer night cooling by tapping the temperature value and entering a new one.**
Outside air must be cooler than extract air by this value. The default value is 1°C.
6. **Set the speed for the supply fan by tapping the percentage value and entering a new one.**
The speed of the supply air fan when summer night cooling is active. The default value is 70%.
7. **Set the speed for the extract fan by tapping the percentage value and entering a new one.**
The speed of the extract air fan when summer night cooling is active. The default value is 70%.
8. **Set the starting time for summer night cooling by tapping the time value and entering a new one.**
Summer night cooling is only allowed after this specified time. The default value is 22:00.
9. **Set the stopping time for summer night cooling by tapping the time value and entering a new one.**
Summer night cooling is stopped after this specified time. The default value is 7:00.
10. **Set the weekday or days for summer night cooling by tapping the value and choosing the days.**
The default value is Every day, which means all the days are selected (green). To unselect a day, click the day symbol and it becomes unselected (gray).
11. **Set active cooling blocked on or off by toggling the value.**
If this setting is on, no active cooling is allowed (geothermal cooling or heat pump). This applies only to units with cooling function.
12. **Tap Continue to accept the Summer night cooling and to enter the Away mode settings.**
13. **Set the supply air fan speed for Away operating mode by tapping the percentage value and entering a new one.**
This value defines the supply air fan speed in Away operating mode. The allowed value range is 20-100%. The default value is 20%.
14. **Set the extract air fan speed for Away operating mode by tapping the percentage value and entering a new one.**
This value defines the extract air fan speed in Away operating mode. The allowed value range is 20-100%. The default value is 20%.
15. **Set the temperature setback value by tapping the temperature value and entering a new one.**
This value defines the temperature drop in the main view temperature display when Away operating mode is on. The default value is 2°C.

16. **Set heating on or off by toggling the value.**

This setting defines whether or not after heating is allowed in Away operating mode.

17. **Set cooling on or off by toggling the value.**

This setting defines whether or not active cooling is allowed in Away operating mode. This applies to units with cooling functionality.

18. **Tap Continue to accept the Away mode settings and to enter the Manual boost settings.**

19. **Set the boost duration by tapping the time value and entering a new one.**

This setting defines the time the fan speed is boosted. The default value is 30 minutes.

20. **Set the supply air boost speed by tapping the percentage value and entering a new one.**

This is the speed with which the supply air fan will be running when manual boosting is activated. The default value is 90%.

21. **Set the extract air fan boost speed by tapping the percentage value and entering a new one.**

This is the speed with which the extract air fan will be running when manual boosting is activated. The default value is 90%.

22. **Tap Continue to accept the Manual boost settings and to enter the Manual overpressure settings.**

23. **Set the overpressure duration by tapping the time value and entering a new one.**

This setting defines the time the overpressure function is on. The default value is 10 minutes. Maximum allowed duration is 60 min. Minimum allowed duration is 1 min.

24. **Set the supply air fan speed during overpressure by tapping the percentage value and entering a new one.**

This is the speed with which the supply air fan will be running when overpressure is activated. The default value is 50%.

25. **Set the extract air fan speed during overpressure by tapping the percentage value and entering a new one.**

This is the speed with which the extract air fan will be running when overpressure is activated. The default value is 30%.

26. **Tap Continue to accept the Manual overpressure settings and to enter the Boost function settings.**

Boost function settings

1. **Tap Continue to proceed from the main page to Humidity boost settings.**

2. **Set the %RH boost on or off by toggling the value.**

This setting allows or prohibits boosting according to the air humidity.

3. **Set the summer/winter limit temperature by tapping the temperature value and entering a new one.**

When the 24 hour mean temperature of outside air is higher than this limit, boosted ventilation based on the 48 hour mean humidity of extract air is taken into use. If the 24 hour mean temperature is below the value set here, a fixed limit for boosted ventilation is used. The default value is +4°C

4. **Set the %RH boosting limit value by tapping the percentage value and entering a new one.**

In winter mode (24 h mean temperature of outside air is less than +4°C) boosted ventilation activates when relative humidity is higher than this value. The default value is 45%.

5. **Set the threshold for 48 hr. %RH by tapping the percentage value and entering a new one.**

In summer mode (24 h mean temperature of outside air is higher than +4°C) boosted ventilation activates when relative humidity of extract air is higher than the 48 h mean humidity by the value set here. The default value is 15%.

6. **Set the maximum speed for the supply air fan by tapping the percentage value and entering a new one.**

The maximum allowed speed of the supply air fan during boosted humidity ventilation. The default value is 90%.

7. **Set the maximum speed for the extract air fan by tapping the percentage value and entering a new one.**

The maximum allowed speed of the extract air fan during boosted humidity ventilation. The default value is 90%.

8. **Set rotor dehumidification to on or off by tapping this setting.**

If allowed rotor dehumidification is active when humidity boosting is active and the outside air temperature is below 0 °C.



NOTE: This function will increase the condensation inside the ventilation unit. The condensation drain must be connected and in working order. Rotor dehumidification will reduce the heat recovery to some extent. The use of rotor dehumidification might require an additional preheater and/or a more powerful after heater.

9. **Tap Continue to accept the Humidity boost settings and enter the CO₂ boost settings.**

CO₂ settings require an external carbon dioxide transmitter (not included in the basic delivery).

10. **Set the CO₂ boosting on or off by toggling the value.**

11. **Set the CO₂ boost limit value by tapping the ppm value and entering a new one.**

Boosting starts when the amount of CO₂ exceeds the value set here.

12. **Set the maximum speed for the supply air fan by tapping the percentage value and entering a new one.**

The maximum allowed speed of the supply air fan during boosted CO₂ ventilation. The default value is 90%.

13. **Set the maximum speed for the extract air fan by tapping the percentage value and entering a new one.**

The maximum allowed speed of the extract air fan during boosted CO₂ ventilation. The default value is 90%.

14. **Tap Continue to accept the CO₂ boost settings and enter the Temperature boost settings.**

Temperature boost increases the fan speed, if the extract or room temperature differs from the temperature setpoint.

15. **Set the temperature boost on or off by toggling the value.**

16. **Select the temperature measurement for the temperature boosting function.**

The options are *Extract air temperature* or *Room temperature average*. To be able to select room temperature average, you need a separate

room temperature sensor (not included in the basic delivery). The default value is Extract air temperature.

17. **Set the maximum speed for the supply air fan by tapping the percentage value and entering a new one.**

The maximum allowed speed of the supply air fan during temperature boost ventilation. The default value is 90%.

18. **Set the maximum speed for the extract air fan by tapping the percentage value and entering a new one.**

The maximum allowed speed of the extract air fan during temperature boost ventilation. The default value is 90%.

19. **Tap Continue to accept the Temperature boost settings and enter the Cooker hood / central vacuum cleaner settings.**

Cooker hood / central vacuum cleaner settings

Overpressure functionality is designed to compensate the air mass flowing out via cooker hood and central vacuum cleaner so that no excessive underpressure is formed.



NOTE: The use and efficiency of overpressure functionality requires that the ventilation system has been designed and built to accommodate it. Note that a state-of-the-art cooker hood might extract as much as 200-300 l/s.



NOTE: During overpressure the heat recovery is essentially off. The heat recovery can only warm up the same amount of supply air than the amount of extract air going through the ventilation unit. The excess supply air must be heated by the after heating. The use of overpressure functionality might require a more powerful afterheater than the standard heater supplied with the ventilation unit.



NOTE: This function requires running indication from the cooker hood and the CVC to the ventilation unit. Turn on the cooker hood and CVC respectively to make the settings.

1. **Set the supply and extract air fan speed for when the cooker hood is on by tapping the percentage value and entering a new one.**

The default value for supply air is 50% and for extract air 30%.

2. **Set the supply and extract air fan speed for when the central vacuum cleaner is on by tapping the percentage value and entering a new one.**

The default value for supply air is 50% and for extract air 30%.

3. **Set the supply and extract air fan speed for when the cooker hood and the central vacuum cleaner are on simultaneously by tapping the percentage value and entering a new one.**

The default value for supply air is 70% and for extract air 30%.

4. **Set the supply and extract air fan speed for when the cooker hood, the central vacuum cleaner and manual overpressure are on simultaneously by tapping the percentage value and entering a new one. The manual overpressure can be activated for this setting by toggling manual overpressure on or off.**

The default value for supply air is 100% and for extract air 30%.

5. **Tap Continue to accept the Cooker hood / central vacuum cleaner settings and enter the Modbus and eAir web settings.**

Modbus and eAir web settings

1. **Tap Continue to proceed from the main page to Modbus settings.**

Ask for the necessary Modbus parameters from the monitoring system supplier.

2. **Set the Modbus identification (address) by tapping the ID value and entering a new one.**

Each device that is connected to the Modbus needs a unique identification. The allowed range of values is 1-100.

3. **Set the Modbus speed by toggling the speed value.**

The options are 19200, 115200 or 9600. The default value is 19200.

4. **Set the Modbus parity by toggling the parity value.**

The options are *None* or *Even*. The default value is *None*.

5. **Tap Continue to accept the Modbus settings and enter the eAir web settings.**

Tap *Settings* and *Enable eAir web*. The device connects to the internet, if the Ethernet cable has been connected to the motherboard. To enable the eAir web connection you must log in to the internet page my.ensto.com with the serial number and pin code given in this menu.

6. **Tap Continue to accept the eAir web settings and to finish the setup wizard.**

Filter Guard (additional equipment)

The Filter Guard monitors the filters in the ventilation unit and notifies the user when the filters are becoming dirty and needs to be changed. The Filter Guard is not to be confused with the service reminder that reminds the user at regular intervals to service the ventilation unit.

If the ventilation unit have been ordered with Filter Guard equipment the following text will be shown:

"The filters are now being tested. After 2 minutes the pressure difference across the filters will be measured, and the measurement will be used to determine the new filter guard alarm limit."

During testing the fans will be on full power.

1. **The first time the setup wizard is completed all settings are automatically stored in non-volatile memory. Subsequent setup wizards will ask if you want to replace the stored settings with the new ones or only take the new settings into use.**
2. **Tap Continue to start using the control panel.**

Setting up system without setup wizard

We strive to prepare the ventilation units at factory to achieve shorter installation times. However, we cannot be prepared for any possible additional equipment purchased separately for the installation. Any equipment that is connected to the motherboard needs to be defined in the control.

See next table for MD card connections and their locations on the motherboard.

MD card connections	
NTC sensors	
MD card has connections for 8 NTC-10 temperature sensors	
Input	Use
X1	Outdoor temperature measuring TE01
X2	Supply air temperature after heat recovery unit TE05
X3	Supply air temperature TE10 Supply air temperature after dehumidification coil TE07 (Only for units with dehumidification)
X4	Exhaust air temperature TE32
X5	Extract air temperature before heat recovery TE31 (HP only) Evaporator coil liquide pipe temperature TE62 (MDX only) Freeze protection for CG coil TE46 (CG-W only)
X6	Preheated extract air temperature TE50 (HP only)
X7	Preheated outside air temperature TE02 (CHG)
X12	Return water temperature TE45
Analog inputs AI 0-10V	
Analog inputs AI1 - AI6 for voltage range 0-10V Functionality of these inputs are decided by user	
Input	Use
AI1 (X16)	Humidity transmitter 1
AI2 (X16)	Humidity transmitter 2 Boiler temperature TE80 (Aqua only)
AI3 (X16)	(Free) Supply duct pressure PDS10
AI4 (X16)	(Free) Extract duct pressure PDS30
AI5 (X15)	Carbon dioxide transmitter 1
AI6 (X15)	Carbon dioxide transmitter 2
The following functions can be assigned to analog inputs AI1 - AI6	
	Humidity transmitter 1, 2 and 3
	Carbon dioxide transmitter 1, 2 and 3
	Room temperature transmitter 1, 2 and 3
	Outside temperature transmitter
	Pressure difference transmitter PDE10 and PDE30. These sensors are used for controlling constant duct pressure
	Changing temperature setpoint
Analog inputs AI7 - AI8 for voltage range 0-5V Functionality of these inputs are locked by software	
AI7 (X29)	Extract air humidity RH30
AI8 (X29)	Extract air temperature TE30
Analog inputs AI9 - AI16 for voltage range 0-10V Functionality of these inputs are locked by software	
AI9 (X10)	Supply filter differential pressure PDE01 (accessory)
AI10 (X10)	Extract filter differential pressure PDE31 (accessory)
AI11 (X10)	Supply air humidity RH10 (only for units with dehumidification)
AI12 (X10)	Supply air temperature TE10 (only for units with dehumidification)
AI13 (X10)	Free
AI14 (X10)	Free
AI15 (X10)	Free

MD card connections	
AI16 (X10)	Free
Analog Outputs AO 0 - 10V	
Output	Use
AO1 (X18)	Control voltage for supply fan
AO2 (X18)	Control voltage for extract fan
AO3 (X16)	Control voltage for cooling / Control voltage for additional after heater (MDX-E/HP-E/HP-W)
AO4 (X18)	Control voltage for HRW
AO5 (X16)	Control voltage for heating / Control voltage for compressor power (MDX/HP)
AO6 (X15)	Control voltage for preheater / Control voltage for pre-cooler (CHG) / Control voltage for HRW #2 (Twin Tropic)
AO7 (X15)	Control voltage for extract air preheater (HP) / Control voltage for extract air dehumidification (TCG) / Control voltage for HRC defrosting (WGHR)
AO8 (X10)	Control voltage for hot water production
Digital outputs DO relays, potential free normally open contacts.	
Output	Use
DO1	ON/OFF Control for fans
DO2	ON/OFF Control for heating
DO3	ON/OFF Control for cooling / ON/OFF control for heating (MDX)
DO4	ON/OFF Control for HRW
DO5	ON/OFF Control for dampers
DO6	ON/OFF Control for preheating / ON/OFF Control for pre-cooling (CHG) / ON/OFF Control for heating circulating pump (Aqua KIW)
DO7	Timer controlled relay / ON/OFF Control for heat accumulator charging pump PU80 (Aqua) / ON/OFF control for extract air cooling (TCG)
DO8	A/AB alarm output NO
Digital inputs DI (buttons and indications). Connection to GND only! No voltage allowed to be connected to digital inputs.	
Digital inputs are user configurable	
Input	Use
DI1 (X16)	Emergency stop (fixed)
DI2 (X16) user configurable	PDS10 supply fan pressure switch / Defrosting indication (MDX/HP)
DI3 (X16) user configurable	Additional time (office mode only)
DI4 (X16) user configurable	Manual boost
DI5 (X15) user configurable	Away mode. Away mode is active as long as the input is grounded.
DI6 (X15) user configurable	Overpressure, connected to a momentary push-button switch. Overpressure is active 10 minutes (factory setting) from when input is grounded. If connected to a changeover switch, the circuit must be cut for the overpressure to reactivate.
DI7 (X15) user configurable	Central vacuum cleaner indication
DI8 (X15) user configurable	Cooker hood indication
DI9 (X18) fixed	HRW tachometer input
DI10 (X17) fixed	Electrical after heater alarm / Compressor fault (MDX/HP)
DI11 (X17) fixed	Supply fan tachometer input
DI12 (X17) fixed	Extract fan tachometer input

MD card connections	
Miscellaneous connections	
X27, X28	Operating panel connections for eAir wall holder only
X26	ModBus RTU
X19	Ethernet
X23 USB host	Software update by USB memory stick only

MD card connections	
X24 USB device	Not in use
X8	+24VDC
X8	GND
O3 Ozone sensor (ION)	Connector 11 on ICEA2000A unit

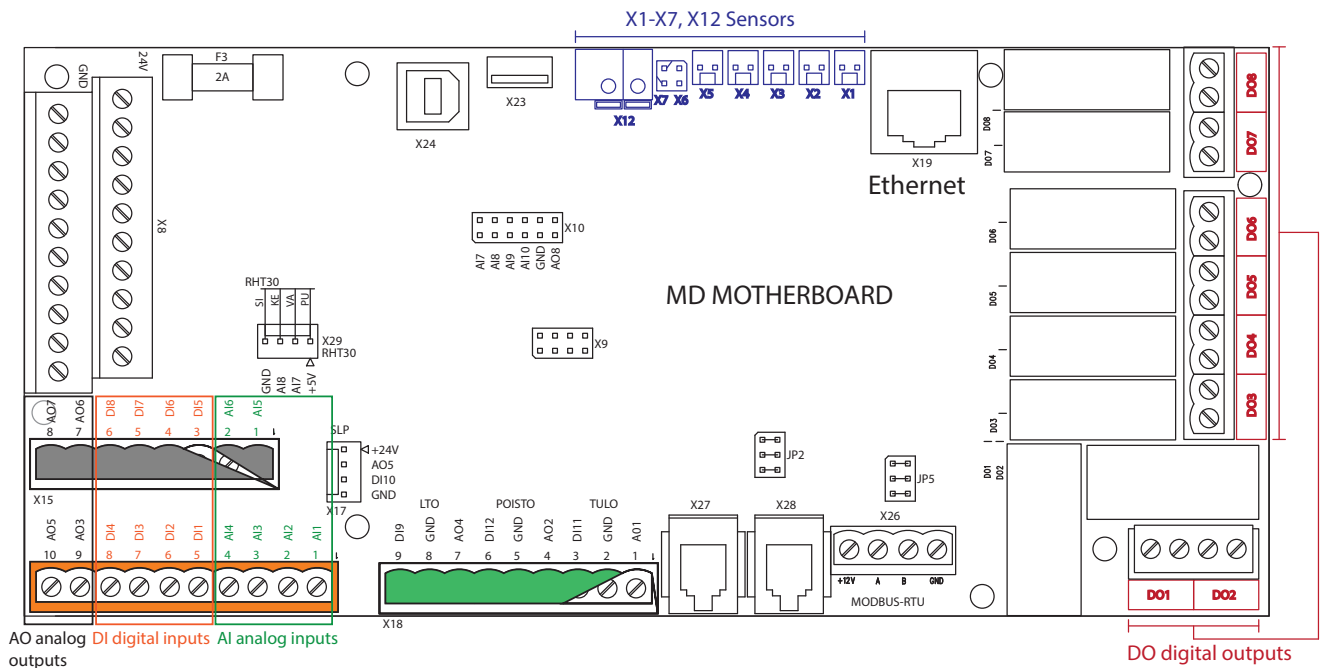

Figure 4. MD card connections and their locations

In order to define your equipment tap on the upwards arrow in the main view > select *Settings* > scroll to *System configuration* > enter password 6143 > OK > *I/O settings* > choose *AI settings* (analog input settings) or *DI settings* (digital input settings) > choose the connection you want to define. Then tap on the green text on the row you want to choose and select the equipment you added from the list that appears.



NOTE: It is very important to write down all the changes made to the parameters. This way the information is backed up in case the automation gets damaged (for example by a lightning).

Use

If at all possible, introduce the end user to proper use of the ventilation unit and the control panel.



NOTE: If you run into problems while using the ventilation unit, please consult the Troubleshooting guide at the end of this manual.

Documenting commissioning

- Fill in the warranty.
- Mark down the possible changes you made to the factory settings in the parameter list at the end of this manual (field settings).
- Fill out the air amount measuring document. A copy of the measuring document is provided at the end of this manual.



NOTE: The warranty does not apply for units with no documented air amount measuring.

General



NOTE: The ventilation unit must never be switched off. It must always be kept running at the power specified by the ventilation designer.

- Ventilation must be sufficient.
If the ventilation is insufficient, the humidity indoors becomes too high and can result in the formation of condensation on cold surfaces.
- Indoors humidity levels must be checked regularly.
A relative humidity of max. 40 - 45 % indoors is recommended (room temperature of +20 - 22°C). At these levels the humidity will be at a healthy level and the risk of condensation is drastically diminished. Humidity levels can be checked with a hygrometer. When the humidity rises above 45 %, ventilation needs to be increased, and when the humidity goes lower than 40%, ventilation can usually be lowered.
- Cleanliness of the filters must be checked regularly.
During winter the extract air filter usually becomes dirtier more quickly than the supply air filter. As a result of this, the extract airflow decreases, which leads to a higher humidity indoors. This also leads to poor heat recovery.

For more information on cleaning and changing filters, please see chapter *Maintenance*.
- Check monthly that the heat exchanger is rotating correctly.
For more information on checking and cleaning the heat exchanger, please see chapter *Maintenance* below.
- If the unit is not to be used for a longer period, it can be shut down if you cover both the outside air intake and the exhaust air outtake.
This way you stop moisture from condensing on for example the fans' electric motors.
- Before the heating season in the Autumn and before there is cooling need (if unit is equipped with cooling) the functionality of the condensation drain(s) must be checked by pouring water into the drain and checking that the water is drained away.

Using eAir control panel

Ventilation is operated mainly by using operating modes. The active mode is shown on the main view of the control panel. The user can select the mode best suited for the situation: *Home, Away, Boost, Overpressure, Silent* or *Max. heating / cooling*. Operating modes *Silent* and *Max. heating / cooling* must be separately activated from the *Settings > Operating modes* menu for them to show in the *Operating modes* menu. *Operating modes* menu can be

accessed by tapping the round button at the center of the control panel main view.



The eco mode can be activated in all modes except for *Away* mode and *Max heating / cooling* mode. The eco mode prevents after heating and active cooling, and maximizes the use of the heat recovery. The heat recovery will be on 100% until the outside air temperature reaches the outside temperature limit for heating temperature, or the supply air reaches the supply air max temperature. If the supply air temperature drops below the supply air minimum temperature the after heating is activated to keep the supply air at the minimum temperature.

The frame around the Operating mode button changes colour according to the operation of the ventilation unit. The frame is green when heat recovery is active, orange and red when heating is active and blue when cooling is active.

Other functions of the ventilation unit can be found in the *Main menu*. The menu can be accessed by tapping the arrow symbol shown at the bottom of the operating unit main view. The menu consists of submenus *Timer Program, Measured values, Alarm, Settings, System info, Service* and *eAir web settings*. For more information on using the menus, please see the User Instructions manual.

If an alarm is issued, it will show as a yellow box on the main view of the control panel. The alarm will most likely be a reminder for changing filters. The cause for an alarm must always be found out. See the *Alarms* menu for the possible cause and for acknowledging the alarm.

Description of operations

Operations

The ventilation unit operating environments are *Home, Office, VAK1, VAK2* or *VAK3*.

Available functions vary according to the operating environment.

- In *Home* mode the unit is running non-stop. This is the default setting.
- In *Office* mode the unit runs according to a time program or an external control system. *Office* mode can be activated from the control panel.

- VAK1,2,3 modes are designed for large properties where the unit is running under an external control subsystem. The unit runs only as prompted by the external system. The VAK modes must be programmed at the factory.

TCG units

TCG ventilation units are special ventilation units with enhanced cooling power and dehumidification functionality. TCG cooling and dehumidification is achieved by circulating a cool liquid, either plain water or a water antifreeze solution (brine). The use and functionality is basically the same as for CG (Cooling Geo) ventilation units, the same liquid could be used, but with enhanced cooling and dehumidification power compared to conventional ventilation units with cooling. This is due to using the rotating heat exchanger for additional cooling and dehumidification. The MD automation controls the cooling and dehumidification completely automatically according to the temperature and humidity set points set by the user.

Twin Tropic units

Twin Tropic ventilation units are special ventilation units featuring twin rotating heat exchangers and a cooling coil for very energy efficient dehumidification and cooling. The first rotating heat exchanger pre cools and dehumidifies the outside air before the incoming air is cooled and dehumidified further in a cooling coil. The supply air is finally heated to an appropriate temperature by a second rotating heat exchanger, that takes the heating energy from the extract air, thereby cooling the extract air to allow the first rotating heat exchanger to pre cool and dehumidify the outside air. This considerably reduces the energy demand for cooling in hot and humid climates.

Fans

When electricity is connected to the ventilation unit the relay controlling the dampers activates and heat recovery turn on full power. After a while the extract fan starts up and after a small delay, also the supply fan. After that the ventilation unit runs according to the defined settings.

The fans are operating at specific speed, based on the prevailing mode. During commissioning of ventilation unit, certain fan speed (or duct pressure) is assigned

to each mode. Supply and extract fans have each their own fan speeds.

Modes that affect the fans are

- Home (Office)
- RH%, CO₂ or temperature boosting
- Away
- Summer night cooling
- Manual boosting
- Overpressure, cooker hood and central vacuum cleaner
- Alarm modes A and AB
- Silent mode
- Max heating/cooling
- Defrosting

Supply and extract fan speed is assigned to each of these modes, not including alarm modes, in which the supply fan has always stopped and extract fan has stopped or is running at minimum speed.

Constant duct pressure control

Constant duct pressure is an alternative to set fan speed. When constant duct pressure is used, a set pressure difference, which is maintained by automation system, is assigned to each mode.

Two pressure difference transmitters 0-10V/24V (optional accessories) can be connected to the ventilation unit mother board. The transmitters measure the difference in pressure between the supply duct (extract duct) and surrounding air. Pressure difference is kept within the target values by changing fan speed. If pressure difference is measured over iris damper, the method used is constant air volume control.

CO₂, humidity and temperature boosting of fans

Speed of ventilation unit fans is controlled by data received from humidity and/or carbon dioxide sensors.

CO₂ and/or humidity content of a space is meant to be kept below the limit set in the control panel. Humidity control commands the fans based on data from internal and possible external humidity transmitters of the ventilation unit. One built-in humidity sensor is included in the standard unit delivery. It is possible to connect three carbon dioxide transmitters and three

humidity transmitters in the ventilation system. The transmitters are optional accessories.

CO₂ boosting, humidity boosting and temperature boosting may activate in *Home* mode. Additionally, humidity boosting may activate also in *Away* mode.

If humidity boosting is not sufficient to remove excess humidity from the premises, the rotor dehumidification function can be activated from the settings menu (*Settings > Boost > Humidity boost > Rotor dehumidification*). When humidity boosting is active, *Rotor dehumidification* activates automatically if the outside air temperature is below 0 °C and the functionality has been activated in the *Settings* menu. This functionality slows the heat exchanger rotation down, so creating conditions for extracting greater volumes of humidity.

Dehumidification of supply air is available in certain ventilation units. The absolute humidity of the supply air is kept at the level defined in *Settings > System configuration > Dehumidification settings*.

Extra time (Office mode)

A ventilation unit in *Office* mode stops if no time program tells the unit to run or if the extra time setting is not active.

The length of the extra time is defined in the control panel and it can be activated from the control panel or using an external control button (extra equipment). Extra time control can be aborted from the control panel. Extra time can also be activated via Modbus.

Overpressure (lighting fireplace)

Overpressure control can be activated directly from the control panel or by using a separate button (extra equipment), which makes lighting a fireplace easier. Length of overpressure and supply and extract fan speed can be set in the control panel. Overpressure control can be aborted from the control panel. Overpressure control lowers the extract fan speed and accelerates the supply fan speed for 10 minutes (default setting).



NOTE: Overpressure function is only to be used as a temporary help for lighting the fire in the fireplace. The combustion air for the fireplace must be brought by other means than the ventilation unit.

Manual boosting

Boosting or airing function is started directly from the control panel. Boosting accelerates both fans for a predefined time (default setting is 30 minutes). Boosting can be aborted from the control panel.

Cooker hood and central vacuum cleaner modes

Switching on cooker hood or central vacuum cleaner modes is possible only through an external control system (potential-free contact). The purpose of these modes is to keep the pressure level in the premises the same regardless of running a cooker hood or a central vacuum cleaner.

Summer night cooling

Summer nights give the opportunity to cool room temperature using cooler night air. During summer night cooling heat recovery and heating are switched off. Fan speed is controlled according to the selected mode. Summer night cooling activates and deactivates automatically after it has been taken into use in the control panel.

Weekly and annual program

Time programming enables a certain mode to activate at a specific time on specific weekdays or between specified dates.

For example if the premises are empty, fans can be kept running at a lower speed by setting up a time program that guides the ventilation unit to enter *Away* mode.

Weekly and annual program settings are made in *Timer program* menu. There are 20 different timer programs for the weekly programs, where you can enter the starting and ending times for the program and also the time program event, according to which the ventilation unit will operate during that set time period. If there is a need for a weekly program to function overnight, both the starting weekday and the ending weekday needs to be selected in the programme.

For annual program there are 5 timer programs where you can enter the starting and ending times and dates for the program and also the time program event,

according to which the ventilation unit will operate during that set time period.

The timer programme includes no check for conflicting programmes. The user himself must make sure there are no conflicting programmes programmed.

Temperature control

Heat recovery

Heat recovery is restricted during summer, if the outside temperature exceeds the set temperature limit +8 °C. During this time the heat recovery unit remains still, unless a separate heating request is issued.

When the temperature drops below +8 °C the heat recovery system is full on. This may lead to contradicting situations especially during spring, when sun heats the rooms even though the outside temperature is still below +8 °C. The set temperature limit can be changed in the control panel.

Cooling recovery

In the summer, the heat exchanger turns fully on when the outside air temperature is more than 1 °C higher than the temperature of extract air. The heat exchanger stops when the outside air temperature is lower than the temperature of extract air. This will help in keeping the room temperature cooler.

Heat recovery anti-freezing

MD automation adjusts the supply and extract fan speeds based on data from temperature measurements, thus preventing freezing of heat exchanger. After the threat of freezing has passed, the fan operation returns to normal. Anti-freezing automation can be initiated in the control panel.

Heat recovery efficiency

The temperature efficiency of the supply and extract air heat recovery is reported as percents in the *Measurements* menu of the control panel.

Supply, extract and room temperature controllers

A supply air controller controls the temperature of the supply air. A ventilation unit can run either as supply air controlled, when the unit seeks to keep the supply air temperature at the temperature defined in the control panel, or it can be run as extract air or room air controlled, when the unit seeks to keep the extract or room air at the temperature defined in the control panel by controlling the supply air controller set point.

Supply air controller takes care that the temperature does not drop below or rise above the values set in the control panel. However if the outside air temperature is below the heat recovery temperature limit (default +8 °C), or ECO mode is active, the supply air temperature is permitted to rise above the temperature set point if the temperature rise is from heat recovery only.

Constant extract (or room) air temperature control is used when heating or cooling the ventilation unit supply air should affect the temperature of the whole premises. This control method is a standard feature in ventilation unit models with cooling.

However if the outside air temperature is below the heat recovery temperature limit (default +8 °C), or ECO mode is active, the extract (or room) air temperature is permitted to rise above the set point temperature if the temperature rise is from heat recovery only.

In order for room temperature control to work, the ventilation unit must be equipped with either a temperature sensor that is connected with the control panel (extra equipment) or with a room temperature transmitter connected to the MD card (extra equipment). Measurements for room temperature must be separately taken into use in the control panel settings.

Heating activates when the MD control asks for heating i.e. the temperature setpoint is above the extract air (or room temperature) measurements. Cooling is on when the MD control asks for cooling i.e. the temperature setpoint is below the extract air (or room temperature) measurements. It is possible for both heating and cooling to be active simultaneously if the ventilation unit is equipped with supply air absolute humidity control (extra equipment).

In W models there is a checking function for the return water of the hydronic coil. Heating activates if the temperature of return water drops below set limit. If the return water temperature drops further, the ventilation unit is switched off and an alarm is issued.

By selecting *Max heating / Max. cooling* in the control panel Operating mode menu, momentarily boosted heating or cooling is activated. This action forces the supply air control at maximum and accelerates the fan to “manual boost” level.

The action remains on until the temperature setting in the control panel main view is reached.

Alarms

In alarm modes the ventilation unit either stops altogether (A alarms, eg. fire alarm) or remains running in a fault state where the extract fan runs at a minimum speed (so called AB alarms, eg. when supply air is too cold).

It is possible to configure the unit so that the extract fan will stop also when an AB alarm occurs.

Filter guard (additional equipment)

The ventilation unit can be equipped with filter guard function as additional equipment. The filter guard gives an alarm if the filters get clogged. The use of filter guard function requires pressure difference sensors to be installed in the ventilation unit to measure pressure difference over the filters. If the ventilation unit is ordered from the factory with filter guard function, the automation will automatically take the filter guard function into use at the end of the setup wizard. The fans will then run at full power for a few minutes to measure the pressure difference over the clean filters, and set the filter guard alarm limit to the appropriate value for clogged filters. After this the filter guard is in use. Alarm for clogged filters will be given if the alarm level set by the automation is exceeded. The Filter guard will test the filters every Wednesday at 12:00 o'clock, in which case the fans will be on full power for a few minutes.

The Filter guard alarm must be acknowledged manually from the *Settings > Alarm > Acknowledge service reminder*, menu. If the filter type or filter manufacturer is changed, the alarm limits for the filter guard must be updated. This is done in the menu: *Settings > Alarm > Update filter alarm limits*.

Maintenance

The unit needs almost no maintenance. The maintenance is mostly limited to

- changing filters
- cleaning heat exchanger
- cleaning fans
- checking the condensation drain.



WARNING: Before you start maintenance, cut the power from the main power switch or from the LTR-series unit by removing the service hatch. Wait for approximately two (2) minutes before starting maintenance work! Although the unit's power supply is cut, the fans will rotate and the electrical coil will be hot for a while.

- The equipment includes moving parts (e.g. fans, HRW motor and belt, compressors and pumps) that are subjected to wear. Due to normal wear these parts will have to be exchanged during the lifetime of the equipment. The normal lifetime of the parts subjected to wear depends on the operating conditions and the operating times, therefore it is not possible to state a normal lifetime for these consumable parts.

Changing filters

The recommended time between filter changes is max. four (4) months for plain and pleated filters and max. six (6) months for bag filters. If class M5 bag filters are used the time between filter changes can be prolonged to one (1) year by regularly vacuuming the filters on the inside. Pleated filters may be cleaned with compressed air, thereby extending the change interval to max six (6) months. The compressed air must be oil free and dry. Vacuuming/cleaning of the M5 plain and F7 bag filters is not allowed. The rubber gaskets for the filters is recommended to be lubricated by silicone oil. This will greatly increase the lifespan for the gaskets.



NOTE: Vacuum cleaning the inside of the unit is recommended at this point.

Changing plain filters

1. Remove the filter cassettes from the device.
2. Loosen the old filter fabric from the frame.
3. Replace the old filter with a new filter fabric.
4. Replace the filter cassette back into the unit so that the support mesh faces towards the heat exchanger.

Changing bag and pleated filters

1. Open the lock.
2. Remove the old filter.
3. Put in a new one. Observe the arrow that indicates the right airflow in pleated filters.
4. Lock the filter lock.

Not all models have filter locks.



NOTE: Make sure to close the service hatch carefully.



NOTE: Dispose of used filters properly. The filterbags can be disposed as normal household waste. Any metallic parts can – after the filter bags have been removed – be taken to the metal recycling.

Cleaning heat exchanger

When changing the filters, check if the heat exchanger is dirty.

If cleaning is required

1. Remove the heat exchanger from the unit.
2. Carefully wash through the air channels with a hand shower using a mild detergent, taking care not to get the motor wet.

or

Blow compressed air through the air channels.



WARNING: Do not use a pressure washer and do not submerge the heat exchanger into water. Let the heat exchanger dry properly before putting it back in the unit.

When restarting the unit after cleaning, check that the heat exchanger wheel can turn freely.

Cleaning fans

When changing filters, also check the condition of the fans.

If cleaning is required

1. Remove the fans from the unit.
2. Clean the fans with a toothbrush or compressed air.

Service of ionizer module.

The ionizer module found in ION ventilation units needs annual cleaning.

Refer to the ionair operating and service manual supplied with the ventilation unit for complete instructions.



WARNING: Risk of electric shock!

Service of the ionizer module may be performed by qualified personnel only. Lethal voltages are present at the ionizer modules when unit is on.

To clean the ionizer module:

1. Switch off the power to the ventilation unit.
2. Locate the IMK ionair slot-in module below the electrical connection box of the ventilation unit.
3. Loosen the four holding screws on the blue frame of the IMK module, remove the electrical connector, and carefully draw out the IMK module, taking care not to damage the ionizer tubes.
4. Detatch the yellow/green earth wire from the screw terminal and loosen the ionizer tube by screwing them counter clockwise.
5. Check the ionizer tubes for damages. The tube will have to be renewed if burned metal mesh, milky or broken glass tube or cracks in the tube socket are find.
6. Spray the ionizer tubes liberally with a solution of 80% alcohol and 20% water, and clean the tubes with a lint free cloth. Also clean the face of the IMK module. Allow the tube and IMK module to dry completely after cleaning before reattaching the ionizer tubes.



WARNING: No detergents other than alcohol and plain water is allowed!

7. Reassemble the ionizer module, connect the ionizer tubes to the ionizer module, turn the tubes clockwise to lock them in place, and reconnect the yellow/green earth wire to the earth terminal next to the ionizer tube.
8. Make sure the ionizer module and the tubes are completely dry after the cleaning. Reattach the module to the ventilation unit, and tighten the locking screws on the frame.
9. Reconnect the electrical cable, and start up the ventilation unit. Run the ventilation unit for at least 1/2 h and check that there is no alarms.

Technical information and attachments

- Models with duct coils (tables 1 and 2)
- List of extra equipment
- Troubleshooting guide
- Table of models and components
- Table of technical features
- Dimensional drawings
- Electrical diagrams
- Principal diagrams
- Control diagrams
- Table of parameters
- Airflow measuring protocol
- Declaration of conformity

Table 1: Afterheating and cooling duct coils

Ventilation unit models that come equipped with duct coils for after heating or cooling. These coils are installed in the supply air duct (after the ventilation unit).

Models with duct coil					
Unit	Hydronic (water) after-heating coil (LxDxH) Duct connection Ø mm	Hydronic (brine) cooling coil (LxDxH) Duct connection Ø mm	Right hand / left hand change	Condensate drain connection	External sensors
Pinion MDW	VEAB CWW 125-3-2,5 276x313x255 mm Ø 125 mm		No	No	TE10 supply air sensor TE45 return water sensor
Pingvin MDE-CG		VEAB CWK 200-3-2,5-L/R 395x415x330 mm Ø 200 mm	Yes	Yes G ½" external thread	TE10 supply air sensor
Pingvin MDW	VEAB CWW 160-3-2,5 276x313x255 mm Ø 160 mm		No	No	TE10 supply air sensor TE45 return water sensor
Pingvin MDW-CG	VEAB CWW 160-3-2,5 276x313x255 mm Ø 160 mm	VEAB CWK 200-3-2,5-L/R 395x415x330 mm Ø 200 mm	Yes (only for cooling coil)	Yes G ½" external thread	TE10 supply air sensor TE45 return water sensor
Pingvin XL MDE-CG		VEAB CWK 200-3-2,5-L/R 395x415x330 mm Ø 200 mm	Yes	Yes G ½" external thread	TE10 supply air sensor
Pingvin XL MDW	VEAB CWW 200-3-2,5 276x398x330 mm Ø 200 mm		No	No	TE10 supply air sensor TE45 return water sensor
Pingvin XL MDW-CG	VEAB CWW 200-3-2,5 276x398x330 mm Ø 200 mm	VEAB CWK 200-3-2,5-L/R 395x415x330 mm Ø 200 mm	Yes	Yes G ½" external thread	TE10 supply air sensor TE45 return water sensor
Pandion MDW-CG		VEAB CWK 200-3-2,5-L/R 395x415x330 mm Ø 200 mm	Yes	Yes G ½" external thread	TE10 supply air sensor
Pegasos XL MDE-CG		VEAB CWK 315-3-2,5 276x560x504 mm Ø 315 mm	No	Yes	TE10 supply air sensor
Pegasos XL MDW-CG		VEAB CWK 315-3-2,5 276x560x504 mm Ø 315 mm	No	Yes	TE10 supply air sensor
LTR-3 MDE-CG		VEAB CWK 200-3-2,5-L/R 395x415x330 mm Ø 200 mm	Yes	Yes G ½" external thread	TE10 supply air sensor
LTR-3 MDW	VEAB CWW 160-3-2,5 276x313x255 mm Ø 160 mm		No	No	TE10 supply air sensor TE45 return water sensor
LTR-3 MDW-CG	VEAB CWW 160-3-2,5 276x313x255 mm Ø 160 mm	VEAB CWK 200-3-2,5-L/R 395x415x330 mm Ø 200 mm	Yes (only for cooling coil)	Yes G ½" external thread	TE10 supply air sensor TE45 return water sensor
LTR-7 MDE-CG		VEAB CWK 250-3-2,5-L/R 396x491x405 mm Ø 250mm	Yes	Yes G ½" exter	TE10 supply air sensor
LTR-7 MDW-CG		VEAB CWK 250-3-2,5-L/R 396x491x405 mm Ø 250mm	Yes	Yes G ½" exter	TE10 supply air sensor
LTR-7-XL MDE-CG		VEAB CWK 315-3-2,5 276x560x504 mm Ø 315mm	No	Yes	TE10 supply air sensor
LTR-7-XL MDW-CG		VEAB CWK 315-3-2,5 276x560x504 mm Ø 315mm	No	Yes	TE10 supply air sensor

Table 2: Preheating and precooling coils

Preheating/precooling coils. These coils are installed in the outside air duct (before the ventilation unit).

	CHG 200	CHG 250	CHG 400
Coil type	VEAB CWK 200-3-2,5-L/R	VEAB CWK 250-3-2,5-L/R	VEAB CWK 400-3-2,5-L/R
Product code	L: K930040501V (left) R: K930040501 (right)	L: K930040502V (left) R: K930040502 (right)	L: K930040503V (left) R: K930040503 (right)
Suits listed Enervent units (NOTE! It is possible to use a bigger coils than listed here)	Pinion, Pingvin, Pingvin XL, Perfect, Pandion, LTR-2, LTR-3, LTR-4	Pelican, LTR-6	Pegasos, LTR-7
Coil duct connection	Ø 200 mm	Ø 250 mm	Ø 400 mm
Coil outer dimensions and weight dry/with fluid	L 395 x H 330 x D 415 mm, 10/11 kg	L 395 x H 405 x D 491 mm, 12/13,5 kg	L 450 x H 529 x D 715 mm, 22/24,7 kg
Filter (plain filter)	1 pcs, filtering class G3 379 x 296 x 13 mm Spare filter package incl. 6 pcs filters (not mesh)	1 pcs, filtering class G3 379 x 296 x 13 mm Spare filter package incl. 6 pcs filters (not mesh)	1 pcs, filtering class G3 379 x 296 x 13 mm Spare filter package incl. 6 pcs filters (not mesh)
Fluid pipe connections	22 mm	22 mm	22 mm
Condense water drain (under pressure)	½ ", must be equipped with water trap	½ ", must be equipped with water trap	½ ", must be equipped with water trap
Valve and valve actuator	Belimo "R313" (R3015-4-S1), 3-way, kvs 4, DN 15 TR24-SR, 0-10V	Belimo "R313" (R3015-4-S1), 3-way, kvs 4, DN 15 TR24-SR, 0-10V	Belimo "R313" (R3015-4-S1), 3-way, kvs 4, DN 15 TR24-SR, 0-10V
Additional outside air sensor	1 pcs 5 m sensor	1 pcs 5 m sensor	1 pcs 5 m sensor

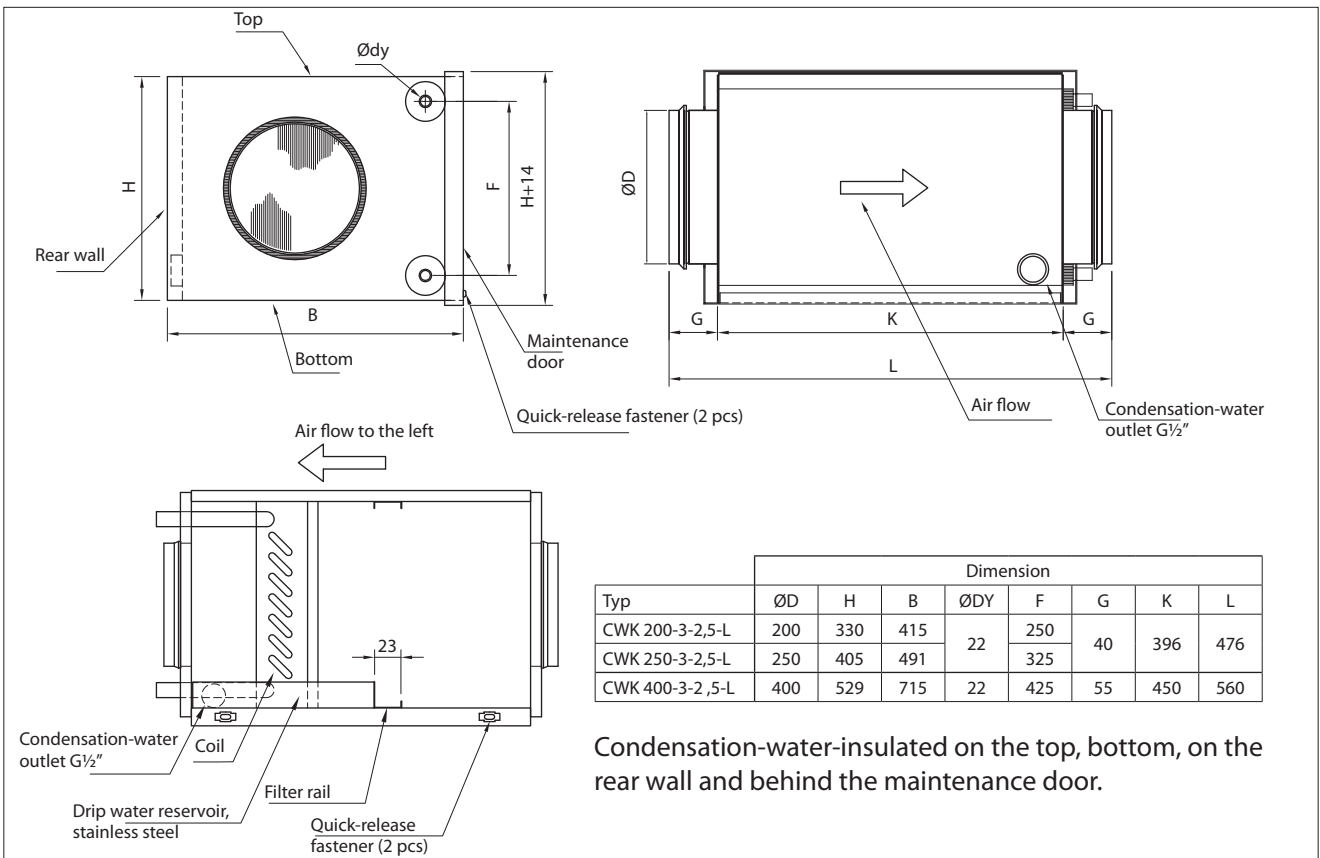

Figure 5. Left handed coil

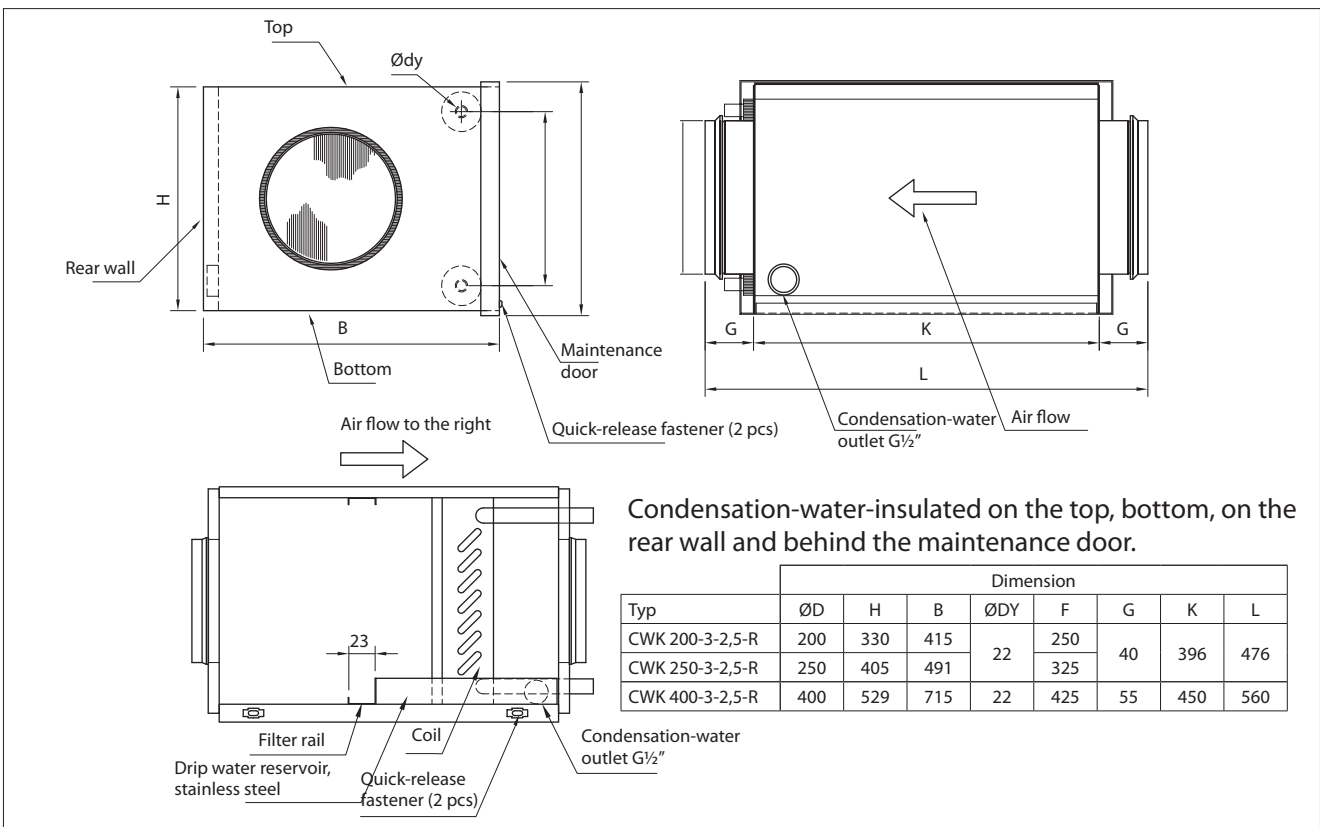

Figure 6. Right-handed coil

Extra equipment available	
K58 003 0001	eAir control panel package. The package includes the control panel, wall mounting bracket and 20 m cable.
K58 003 0002	eAir USB charger
K93 003 0004	CO ₂ carbon dioxide transmitter for installation on the wall 0-10V / 24V
K93 003 0005	CO ₂ carbon dioxide transmitter with display for installation on the wall 0-10V / 24V
M23 010 0007	Built-in CO ₂ carbon dioxide sensor T8031
K91 103 0022	CO carbon monoxide sensor
K93 003 0006	%RH humidity transmitter for installation on the wall 0-10V / 24V
K93 003 0026	% RH humidity transmitter with display for installation on the wall KLH 100-N
K93 003 0008	Push button for activating over pressure/boosting
K93 001 0015	Dual push button for activating home/away + boosting
M41 002 0001	Push button for activating over time function LAP5
K93 003 0010	Pressure difference switch 20-200 Pa for indication of cooker hood/central vacuum cleaner
K93 003 0011	Pressure difference transmitter 0-200 Pa 0-10 V / 24 V for filters and duct pressure
K93 003 0023	Presence detector LA14
K93 002 0028	Room temperature sensor
K93 003 0027	KNX gateway
K93 014 0004	Damper Ø 125 mm (without isolation, tightness class 3)
K93 002 0001	Damper Ø 160 mm (without isolation, tightness class 3)
K93 002 0002	Damper Ø 200 mm (without isolation, tightness class 3)
K93 002 0003	Damper Ø 250 mm (without isolation, tightness class 3)
K93 002 0004	Damper motor with spring return 230 VAC, 4 Nm
K93 002 0006	Manometer 0-250 Pa membrane functional, indicating (for HRW, filters)

Troubleshooting

Alarm	Description	Alarm limit	Symptoms	Possible reason	Action	Notes	
TE05 min	Supply air after heat exchanger is cold.	+5°C	Supply air is cold.	Heat exchanger is not rotating:		The ventilation unit enters the malfunction status, which means that the extract air fan is at minimum speed and the supply air fan has stopped.	
TE10 min	Supply air is cold.	+10°C		<ul style="list-style-type: none"> drive belt is broken drive belt is slipping heat exchanger motor has broken down 	<p>Replace the drive belt.</p> <p>Clean the belt and the heat exchanger.</p> <p>Replace the heat exchanger motor.</p>		
HRC	Alarm from the heat exchanger's rotation guard.			Extract fan has stopped.	Replace the fan.		
				Extract filter is blocked.	Replace the filter.		
ELH alarm	Electric after heater is overheating			Extract air valves are not open enough.	Adjust the valves according to the ventilation system design, using appropriate measuring tools.		
TE45 min	Water coil is freezing.	+8°C		Ventilation is adjusted incorrectly / not adjusted at all.	Readjust/adjust ventilation according to the ventilation system design, using appropriate measuring tools.		
				Heat insulation for the ducts is inadequate.	Check the thickness of the insulation in supply and extract air channels and add insulation, if needed.		
				Ventilation unit fan speed is incorrect.	Always use the fan speed specified by the ventilation system designer (even in winter)		
				Electric after heater is not functioning:			The unit will not start before the alarm has been acknowledged.
				<ul style="list-style-type: none"> overheating protector has tripped supply air fan has stopped supply air filter is blocked outside air grating is blocked controller card of heater is broken heater is broken 	<p>Find out the reason for overheating and acknowledge the error message and "R" button on heater.</p> <p>Find out why / replace the fan.</p> <p>Replace the filter.</p> <p>Clean the grating. Remove possible mosquito net.</p> <p>Replace the controller card.</p> <p>Replace the heater.</p>		
			Water coil has frozen / is about to freeze:				
			<ul style="list-style-type: none"> circulation pump has stopped heat exchanger is not rotating actuator of the water coil's control valve is faulty extract fan has stopped 	<p>Restart the pump.</p> <p>Replace the motor or the belt.</p> <p>Replace the actuator.</p> <p>Find out why / replace the fan.</p>			

Alarm	Description	Alarm limit	Symptoms	Possible reason	Action	Notes
TE10 max	Supply air is hot, fire hazard.	+55°C	Supply air is hot.	Electric after heater is malfunctioning.	Replace or fix the heater.	The unit will not start before the alarm has been acknowledged.
				Actuator of the water coil's control valve is faulty.	Replace or fix the actuator.	
				TE10 temperature sensor is faulty. Fire hazard.	Replace the sensor. Check the connectors.	
TE20 max	Indoor air is hot, fire hazard.	+55°C	Alarm activates. Indoor air is hot.	TE20 temperature sensor is faulty. Fire hazard.	Replace the sensor. Check the connectors.	
TE30 min	Extract air is cold.	+15°C	Alarm activates. Extract air is cold. Supply air is cold.	Heat insulation in the channels is inadequate.	Check the thickness of the insulation in supply and extract air channels and add insulation, if needed.	The ventilation unit enters the malfunction status, which means that the extract air fan is at minimum speed and the supply air fan has stopped.
				Ventilation unit door is open.	Close the door.	
				Indoor temperature is low.	Turn the temperature higher.	
				TE30 temperature sensor is faulty.	Replace or fix the sensor.	
TE30 max	Extract air is hot.	+55°C	Alarm activates. Extract air is hot.	TE30 temperature sensor is faulty. Fire hazard.	Replace or fix the sensor.	The unit will not start before the alarm has been acknowledged.
Supply air fan		Alarm from the supply air fan rotation guard.	Supply air fan has stopped.	Replace or fix the supply air fan.		
Extract air fan		Alarm from the extract air fan rotation guard.	Extract air fan has stopped.	Replace or fix the extract air fan.		
Emergency stop	External emergency stop is activated.		Emergency stop alarm activates. Ventilation unit has stopped.	Fire or other similar hazardous situation.	Find out the reason for the alarm.	
Service reminder	Certain amount of time has passed since the last maintenance.		Maintenance reminder alarm activates.		Replace the filters and check that the ventilation unit is clean and undamaged.	
PDS10	Alarm from the pressure guard.		Alarm activates. Ventilation unit has stopped.	The measured pressure difference over the supply fan has dropped below the alarm limit. <ul style="list-style-type: none"> • supply air fan has stopped • supply air filter is blocked • outside air grating is blocked • PDS10 pressure difference switch is faulty. 	Find out the reason for the alarm.	The use of electric heating coil is prohibited until the difference in pressure has recovered.

Alarm	Description	Alarm limit	Symptoms	Possible reason	Action	Notes
Supply air pressure	Alarm from the differential pressure transmitter in the supply air channel.	10 Pa	Alarm activates. Ventilation unit has stopped.	Deviation in the channel pressure. The deviation can be adjusted.	Find out the reason for the alarm.	
Extract air pressure	Alarm from the differential pressure transmitter in the extract air channel.	10 Pa	Alarm activates. Ventilation unit has stopped.	Deviation in the channel pressure. The deviation can be adjusted.	Find out the reason for the alarm.	
			Air flow has diminished.	Filters are blocked.	Replace the filters.	
				Fan runs at too low speed.	Speed up the fan.	
				Outside air grating is blocked.	Clean the grating. Remove possible mosquito net.	
				Fan blades are dirty.	Clean the fans.	
			Ventilation unit noise level has risen.	Filters are blocked.	Replace the filters.	
				Fan bearings are faulty.	Replace the fan.	
				Outside air grating is blocked.	Clean the grating. Remove possible mosquito net.	
				Fan blades are dirty.	Clean the fans.	
				Heat exchanger motor/gearbox is faulty.	Replace the motor/gearbox.	



WARNING: Risk of electric shock! High voltage present in the ionizer module! Service by qualified personnel only!

Alarm	Description	Symptoms	Possible reason	Action	Notes
Alarm indication on the Ionizer ICE/A 2000 control module					Alarm is automatically acknowledged when alarm condition is over
Insufficient supply air flow	Ionizer functioning on reduced power or off completely	Insufficient filtration of supply air	Supply filter is blocked	Replace the filter	
			Supply fan has stopped	Replace or fix the supply air fan	
Humidity of supply air is too high			Condensation drain does not function.	Repair the condensation drain	
			Insufficient ventilation	Increase the ventilation	
Ionizer module is overheating			Ionizer tubes dirty or damaged	Clean or replace the ionizer tubes	

MODELS AND COMPONENTS

EN

Model	MD control system with eAir touch panel	No afterheating / -cooling	Built-in electrical afterheating	Water-to-air after-heating*		Liquid circulation cooling (geo-cooling)*	
				Built-in	Duct coil	Built-in	Duct coil
Components included in the delivery	eAir touch panel set			Freeze protection system, 2-way valve, valve actuator	Duct coil, freeze protection system, 2-way valve, valve actuator, duct sensor	3-way valve, valve actuator, relay control for pump	Duct coil for cooling, 3-way valve, valve actuator, relay control for pump, duct sensor
Pinion MDE	X		X				
Pinion MDW	X				X		
Pingvin MD	X	X					
Pingvin MDE	X		X				
Pingvin MDE-CG	X		X				X
Pingvin MDW	X				X		
Pingvin MDW-CG	X				X		X
Pingvin XL MD	X	X					
Pingvin XL MDE	X		X				
Pingvin XL MDE-CG	X		X				X
Pingvin XL MDW	X				X		
PingvinXL MDW-CG	X				X		X
Pandion MD	X	X					
Pandion MDE	X		X				
Pandion MDE-CG	X		X			X	
Pandion MDW	X			X			
Pandion MDW-CG	X			X			X
Pandion MDCG-W	X				X	X	
Pandion TCG	X	X (no after-heating)				X	
Pandion TCG-E	X		X			X	
Pandion TCG-W	X				X	X	
Pelican MD	X	X					

* HVAC planner defines the size of the circulation pump.

Model	MD control system with eAir touch panel	No afterheating / -cooling	Built-in electrical afterheating	Water-to-air after-heating*		Liquid circulation cooling (geo-cooling)*	
				Built-in	Duct coil	Built-in	Duct coil
Components included in the delivery	eAir touch panel set			Freeze protection system, 2-way valve, valve actuator	Duct coil, freeze protection system, 2-way valve, valve actuator, duct sensor	3-way valve, valve actuator, relay control for pump	Duct coil for cooling, 3-way valve, valve actuator, relay control for pump, duct sensor
Pelican MDE	X		X				
Pelican MDE-CG	X		X			X	
Pelican MDW	X			X			
Pelican MDW-CG	X			X		X	
Pelican MDWG-W	X			X		X	
Pegasos MD	X	X					
Pegasos MDE	X		X				
Pegasos MDE-CG	X		X			X	
Pegasos MDW	X			X			
Pegasos MDW-CG	X			X		X	
Pegasos MDWG-W	X			X		X	
Pegasos Twin Tropic CW	X	X (no after heating)				X	
Pegasos Twin Tropic CW-E	X		X			X	
Pegasos XL MD	X	X					
Pegasos XL MDE	X		X				
Pegasos XL MDE-CG	X		X				X
Pegasos XL MDW	X			X			
Pegasos XL MDW-CG	X			X			X
Pegasos XL MDWG-W	X				X	X	
Pallas MDE	X (Built in)		X				
Pallas MDWG-E	X (Built in)		X			X	
Pallas MDW	X (Built in)			X			

* HVAC planner defines the size of the circulation pump.

Model	MD control system with eAir touch panel	No afterheating / -cooling	Built-in electrical afterheating	Water-to-air after-heating*		Liquid circulation cooling (geo-cooling)*	
				Built-in	Duct coil	Built-in	Duct coil
Components included in the delivery	eAir touch panel set			Freeze protection system, 2-way valve, valve actuator	Duct coil, freeze protection system, 2-way valve, valve actuator, duct sensor	3-way valve, valve actuator, relay control for pump	Duct coil for cooling, 3-way valve, valve actuator, relay control for pump, duct sensor
Pallas MDCG-W	X (Built in)			X		X	
Pallas WG MDW	X (Built in)			X			
Pallas TCG	X (Built in)	X (no after heating)				X	
Pallas TCG-E	X (Built in)		X			X	
Pallas TCG-W	X (Built in)			X		X	
LTR-2 MD	X	X					
LTR-2 MDE	X		X				
LTR-2 MDW	X			X			
LTR-3 MD	X	X					
LTR-3 MDE	X		X				
LTR-3 MDE-CG	X		X				X
LTR-3 MDW	X				X		
LTR-3 MDW-CG	X				X		X
LTR-4 MD	X	X					
LTR-4 MDE	X		X				
LTR-4 MDE-CG	X		X			X	
LTR-4 MDCG-W	X			X		X	
LTR-4 MDW	X			X			
LTR-4 MDW-CG	X			X		X	
LTR-6-190 MD	X	X					
LTR-6-190 MDE	X		X				
LTR-6-190 MDE-CG	X		X			X	

* HVAC planner defines the size of the circulation pump.

Model	MD control system with eAir touch panel	No afterheating / -cooling	Built-in electrical afterheating	Water-to-air after-heating*		Liquid circulation cooling (geo-cooling)*	
				Built-in	Duct coil	Built-in	Duct coil
Components included in the delivery	eAir touch panel set			Freeze protection system, 2-way valve, valve actuator	Duct coil, freeze protection system, 2-way valve, valve actuator, duct sensor	3-way valve, valve actuator, relay control for pump	Duct coil for cooling, 3-way valve, valve actuator, relay control for pump, duct sensor
LTR-6-190 MDW	X			X			
LTR-6-190 MDW-CG	X			X		X	
LTR-7 MD	X	X					
LTR-7 MDE	X		X				
LTR-7 MDE-CG	X		X				X
LTR-7 MDW	X			X			
LTR-7 MDW-CG	X			X			X
LTR-7 XL MD	X	X					
LTR-7 XL MDE	X		X				
LTR-7 XL MDE-CG	X		X				X
LTR-7 XL MDW	X			X			
LTR-7 XL MDW-CG	X			X			X

* HVAC planner defines the size of the circulation pump..

TECHNICAL FEATURES

EN

Technical features are subject to change without prior notice. The declared AHU performance values are indicative only. The performance of a given AHU under certain conditions must be checked from the Energy Optimizer calculation program on the Ensto Enervent web site.

PINION, PINGVIN, PINGVIN XL, PANDION, PELICAN, PEGASOS, PEGASOS XL, TWIN TROPIC, PALLAS										
UNIT:	PINION	PINGVIN	PINGVIN XL	PANDION	PELICAN	PEGASOS	PEGASOS XL	TWIN TROPIC	PALLAS	
Width	589 mm	780 mm	785 mm	998 mm	1 250 mm	1 250 mm	1 250 mm	1 250 mm	1 800 mm	
Depth	320 mm	555 mm	543 mm	590 mm	677 mm	677 mm	677 mm	677 mm	890 mm	
Height	630 mm	540 mm	895 mm	1 270 mm	1 400 mm	1 400 mm	1 400 mm	1 400 mm	1 610 mm	
Weight	45 kg	63 kg	90 kg	125 kg	203 kg	203 kg	203 kg	220 kg	450 kg	
Duct size	Ø 125 mm	Ø 160 mm	Ø 160 mm TCG Ø 200 mm	Ø 200 mm	Ø 250 mm	Ø 250 mm	Ø 250 mm	Ø 250 mm	300x600 mm	
EC fans supply and extract	117 W / 1,05 A	117 W / 1,05 A	163 W / 1,3 A	170 W / 1,22 A	520 W / 3,15 A	520 W / 3,15 A	545 W / 3,5 A	520 W / 3,15 A	400 V 3~ / 1 kW, 1,6 A	
Control card 5x20 mm Glass tube fuse	T2,0 A	T2,0 A	T2,0 A	T2,0 A	T2,0 A	T2,0 A	T2,0 A	T2,0 A	T2,0 A	
Heat exchanger motor with heat protection	5 W, 0,04 A	5 W, 0,04 A	5 W, 0,04 A	5 W, 0,04 A	5 W, 0,04 A	5 W, 0,04 A	5 W, 0,04 A	5 W, 0,04 A	25W, 0,11 A	
Power of standard electrical afterheater coil	400 W	400 W	800 W	2 000 W	4 000 W	4 000 W	4 000 W	4 000 W	9 000 W	
Power of optional electrical afterheater coil	-	800 W	-	4 000 W	6 000 W	6 000 W	6 000 W	6 000 W	6 000 W 12 000 W	
Mains supply	230 V~/50 Hz 10 A	230 V~/50 Hz 10 A	230 V~/50 Hz 10 A	230 V~/50 Hz 16 A	400 V 3~/50 Hz 3x16 A	400 V 3~/50 Hz 3x16 A	400 V 3~/50 Hz 3x16 A	400 V 3~/50 Hz 3x16 A	400 V 3~/50 Hz 3x20 A	
Hydronic afterheater location	In duct	In duct	Built-in	Built-in	Built-in	Built-in	Built-in	-	Built-in	
35/25°C total coil power	1,3 kW*	1,5 kW*	2,6 kW	-	6,4 kW*	6,4 kW*	7,7 kW*	-	19,25 kW	
30/20°C total coil power	-	1,3 kW	2,8 kW*	3,2 kW*	-	-	-	-	-	
60/40°C total coil power	1,8 kW	2,0 kW	3,0 kW	3,5 kW	6,2 kW	6,2 kW	6,7 kW	-	-	
Mains supply	230 V~/50 Hz 10 A	230 V~/50 Hz 10 A	230 V~/50 Hz 10 A	230 V~/50 Hz 10 A	230 V~/50 Hz 10 A	230 V~/50 Hz 10 A	230 V~/50 Hz 10 A	-	400 V 3~/50 Hz 3x10 A	
Pipe connection	10 mm	10 mm	15 mm	15 mm	28 mm	28 mm	28 mm	-	28 mm	
Water flow	0,03 l/s	0,04 l/s	0,07 l/s	0,08 l/s	0,15 l/s	0,15 l/s	0,19 l/s	-	0,46 l/s	
F-models										
W-models										

W-models		PINION	PINGVIN	PINGVIN XL	PANDION (TCG)	PELICAN	PEGASOS	PEGASOS XL	TWIN TROPIC CW / CW-E	PALLAS (TCG)
Water system pressure loss	8,2 kPa	10,3 kPa	5,9 kPa	6,6 kPa	9,2 kPa	2,3 kPa	3,3 kPa	-	15 kPa	
Kvs value of valve	0,63	0,63	1,0	1,0	1,6	1,6	4,0	-	6,3	
Valve connection DN	15	15	15	15	15	15	15	-	25	
Dimensions of duct coils (w x h x l) mm	313x255x276 Ø 125 mm	313x255x276 Ø 160 mm	398 x 330 x 276 Ø 200 mm	-	-	-	-	-	-	
Cooling (CG) coil location	-	In duct	In duct	Built in (CG/TCG) / In duct (CG)	Built-in	Built-in	In duct	Built-in	Built-in	
Total coil power	-	0,9 kW	1,2 kW	1,5 kW (built-in) 1,2 kW (duct)	1,7 kW	3,2 kW	3,5 kW	11,1 kW (100% water)	16,35 kW	
TCG total coil power	-	-	-	Supply 2,4 kW Extract 1,4 kW	-	-	-	-	Supply 12,4 kW Extract 7 kW	
Pipe connection	-	22 mm	22 mm	15 mm (built-in) 22 mm (duct)	15 mm	28 mm	22 mm	28 mm	28 mm TCG 35 mm	
Brine flow	-	0,05 l/s	0,06 l/s	0,08 l/s (built-in) 0,07 l/s (duct)	0,09 l/s	0,16 l/s	0,17 l/s	0,53 l/s (100% water)	0,78 l/s	
TCG water flow	-	-	-	Supply 0,104 l/s Extract 0,043 l/s	-	-	-	-	0,8 l/s	
Water system pressure loss	-	5,7 kPa	7,9 kPa	1,5 kPa (built-in) 7,7 kPa (duct)	2,0 kPa	3,4 kPa	8,5 kPa	56 kPa (100% water)	20 kPa	
TCG water system pressure loss	-	-	-	Supply 16,8 kPa Extract 3,4 kPa	-	-	-	-	23 kPa	
Kvs value of valve	-	1,6	2,6	1,6	4,0	4,0	6,3	4,0	10,0	
Valve connection DN	-	15	15	15	15	20	25	20	25	
Dimensions of duct coil (w x h x l) mm	-	415x330x395 Ø 200 mm	415x330x395 Ø 200 mm	415x330x395 Ø 200 mm	-	-	560x504x276 Ø 315 mm	-	-	

* = standard coil  = standard coil information

UNIT:	PINION	PINGVIN	PINGVIN XL	PANDION (TCG)	PELICAN	PEGASOS	PEGASOS XL	TWIN TROPIC CW / CW-E	PALLAS (TCG)
Total coil power summer/winter	0,9 / 1,8 kW	1,0 / 2,1 kW	1,3 / 3,1 kW	1,3 / 3,1 kW	1,9 / 4,5 kW	3,6 / 8,1 kW	3,8 / 8,9 kW	3,6 / 8,1 kW	-
Pipe connection	22 mm	22 mm	22 mm	22 mm	22 mm	22 mm	22 mm	22 mm	-
Brine flow summer/winter	0,05 / 0,10 l/s	0,05 / 0,11 l/s	0,07 / 0,17 l/s	0,07 / 0,17 l/s	0,10 / 0,24 l/s	0,19 / 0,43 l/s	0,2 / 0,47 l/s	0,19 / 0,43 l/s	-
Water system pressure loss	3,8 / 9,9 kPa	4,2 / 12,2 kPa	5,7 / 32,5 kPa	5,7 / 32,5 kPa	5,7 / 6,3 kPa	6,6 / 27,7 kPa	7,1 / 35,5 kPa	6,6 / 27,7 kPa	-
Kvs value of valve	4,0	4,0	4,0	4,0	4,0	6,3	6,3	6,3	-
Valve connection DN	15	15	15	15	20	25	25	25	-
Dimensions of duct coil (w x h x l) mm	415x330x395 Ø 200 mm	415x330x395 Ø 200 mm	415x330x395 Ø 200 mm	415x330x395 Ø 200 mm	491x405x395 Ø 250 mm	715x529x450 Ø 400 mm	715x529x450 Ø 400 mm	715x529x450 Ø 400 mm	-

* = standard coil  = standard coil information

LTR-2, LTR-3, LTR-4, LTR 6, LTR 7, LTR-7-XL

UNIT:	LTR-2	LTR-3	LTR-4	LTR-6	LTR-7	LTR-7-XL
Width	972 mm	833 mm	1455 mm	1 190 mm	1 510 mm	1 510 mm
Depth	393 mm	480 mm	536 mm	660 mm	707 mm	707 mm
Height	362 mm	510 mm	594 mm	660 mm	720 mm	720 mm
Weight	41 kg	52 kg	85 kg	96 kg	130 kg	130 kg
Duct size	Ø 125 mm	Ø 160 mm	Ø 200 mm	Ø 200 mm	Ø 250 mm	Ø 250 mm
EC fans supply and extract	117 W, 1,05 A	117 W, 1,05 A	163 W, 1,30 A	170 W, 1,22 A	520 W, 3,3 A	545 W, 3,5 A
Control card 5x20 mm Glass tube fuse	T2,0 A	T2,0 A	T2,0 A	T2,0 A	T2,0 A	T2,0 A
Heat exchanger motor with heat protection	5 W, 0,04 A	5 W, 0,04 A	5 W, 0,04 A	5 W, 0,04 A	5 W, 0,04 A	5 W, 0,04 A
Power of standard electrical afterheater coil	400 W	500 W	800 W	2 000 W	4 000 W	4 000 W
Power of optional electrical afterheater coil	-	800 W	-	4 000 W	6 000 W	6 000 W
Mains supply	230 V~/50 Hz 10 A	230 V~/50 Hz 10 A	230V~/50 Hz 10 A	230 V~/50 Hz 16 A	400 V 3~/50 Hz 3x16 A	400 V 3~/50 Hz 3x16 A
Hydronic afterheater location	Built-in	In duct	Built-in	Built-in	Built-in	Built-in
35/25°C total coil power	1,6 kW*	1,8 kW*	-	3,7 kW*	5,3 kW*	7,4 kW*
30/20°C total coil power	-	-	2,6 kW*	4,3 kW	6,3 kW	7,3 kW

F-models

W-models

UNIT:	LTR-2	LTR-3	LTR-4	LTR-6	LTR-7	LTR-7-XL
60/40°C total coil power	1,7 kW	2,3 kW	2,6 kW	3,8 kW	7,1 kW	7,7 kW
Mains supply	230 V~/50 Hz 10 A	230 V~/50 Hz 10 A	230V~/50 Hz 10 A	230 V~/50 Hz 10 A	230 V~/50 Hz 10 A	230 V~/50 Hz 10 A
Pipe connection	15 mm	10 mm	15 mm	22 mm	22 mm	28 mm
Water flow	0,032 l/s	0,04 l/s	0,06 l/s	0,09 l/s	0,13 l/s	0,18 l/s
Water system pressure loss	8,6 kPa	13,7 kPa	4,5 kPa	3,5 kPa	7,0 kPa	4,2 kPa
Kvs value of valve	0,63	0,63	1,0	1,6	2,5	4,0
Valve connection DN	15	15	15	15	15	15
Dimensions of duct coils (w x h x l) mm	-	313x255x356 Ø 160 mm	-	-	-	-
Cooling (CG) coil location	-	In duct	Built-in	Built-in	In duct	In duct
Total coil power	-	1,0 kW	2,0 kW**	2,4 kW	2,1 kW	3,5 kW
Pipe connection	-	22 mm	15 mm	22 mm	22 mm	22 mm
Brine flow	-	0,05 l/s	0,11 l/s**	0,12 l/s	0,11 l/s	0,17 l/s
Water system pressure loss	-	6,3 kPa	16,5 kPa**	2,8 kPa	5,9 kPa	8,47 kPa
Kvs value of valve	-	1,6	1,6	4,0	4,0	4,0
Valve connection DN	-	15	15	15	15	15
Dimensions of duct coil (w x h x l) mm	-	415x330x395 Ø 200 mm	-	-	491x405x395 Ø 250 mm	560x504x276 Ø 315 mm
Total coil power summer/winter	0,95 / 1,8 kW	1,1 / 2,6 kW	1,9 / 3,2 kW	2,3 / 4,7 kW	3,6 / 8,1 kW	3,8 / 8,9 kW
Pipe connection	22 mm	22 mm	22 mm	22 mm	22 mm	22 mm
Brine flow summer/winter	0,05 / 0,10 l/s	0,06 / 0,14 l/s	0,1 / 0,1 l/s	0,13 / 0,25 l/s	0,19 / 0,43 l/s	0,2 / 0,47 l/s
Water system pressure loss	3,8 / 9,9 kPa	4,8 / 18,1 kPa	6,7 / 7,8 kPa	7,6 / 32,9 kPa	6,6 / 27,7 kPa	7,1 / 35,5 kPa
Kvs value of valve	4,0	4,0	4,0	4,0	6,3	6,3
Valve connection DN	15	15	20	20	25	25
Dimensions of duct coil (w x h x l) mm	415x330x395 Ø 200 mm	415x330x395 Ø 200 mm	491x405x395 Ø 250 mm	491x405x395 Ø 250 mm	715x529x450 Ø 400 mm	715x529x450 Ø 400 mm

* = standard coil  = standard coil information ** = 40% Ethylene-Glycol solution

DIMENSIONAL DRAWINGS

EN

Pinion right hand

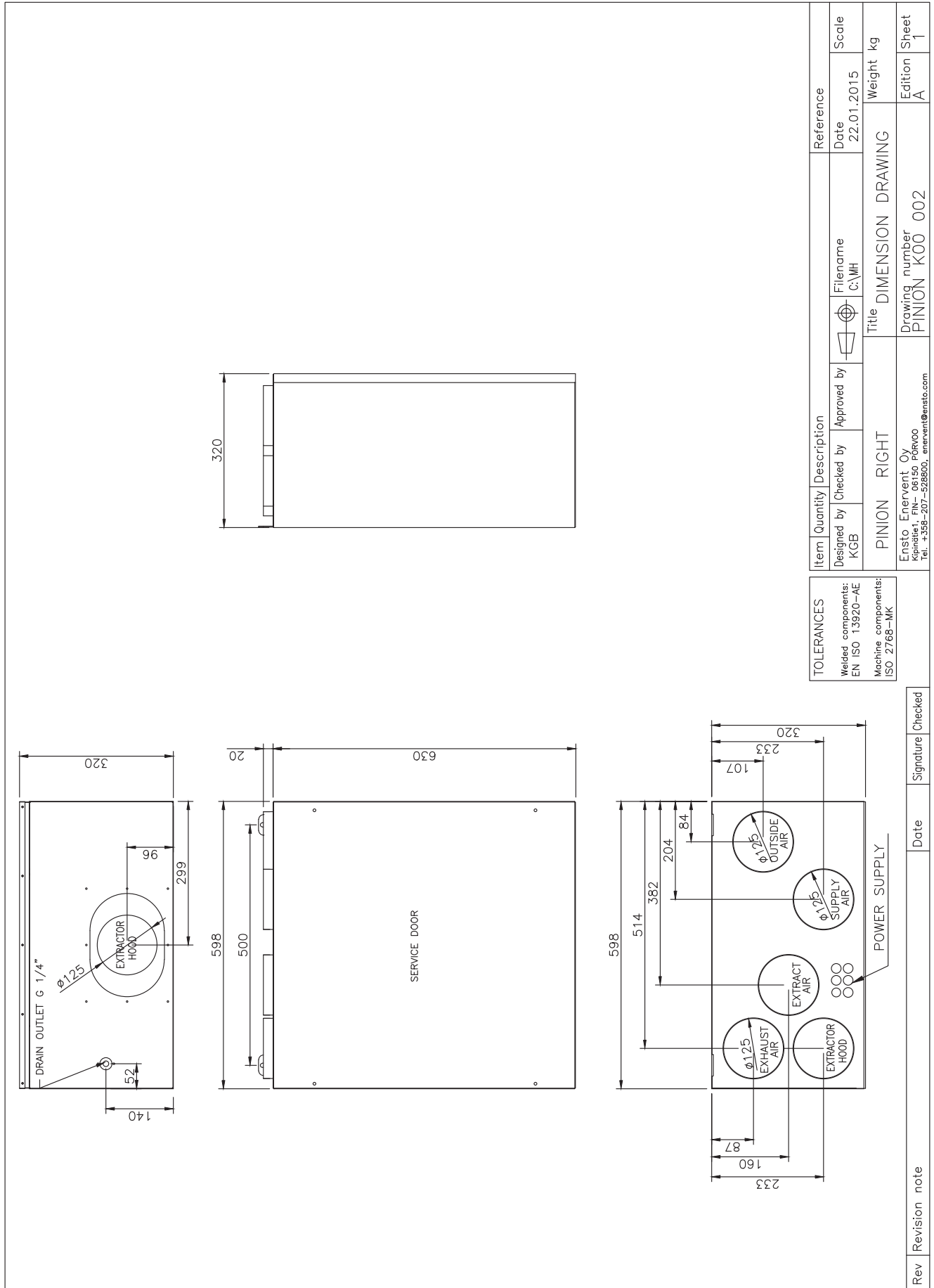

TOLERANCES
 Welded components:
 EN ISO 13920-AE
 Machine components:
 ISO 2768-MK

Item	Quantity	Description	Reference
Designed by	Checked by	Approved by	Date
KGB			22.01.2015
Title			Scale
DIMENSION DRAWING			Weight kg
Drawing number			Edition
PINION K00 002			A
Sheet			1

Ensto, Enervent Oy
 Puhelin: +358-207-928600, faksi: +358-207-928601, email: enervent@ensto.com

Rev	Revision note	Date	Signature	Checked

Pinion left hand

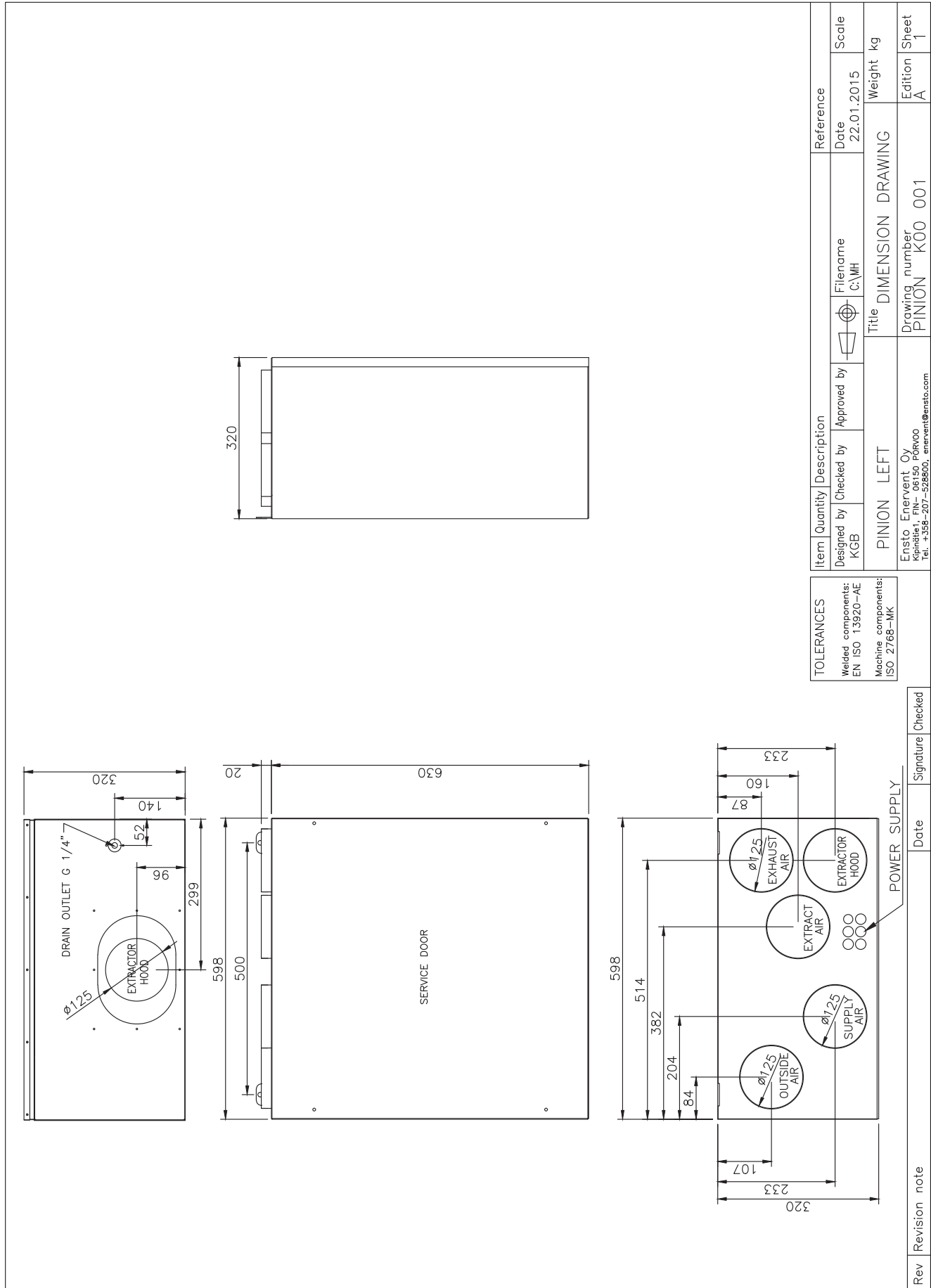

TOLERANCES
 Welded components:
 EN ISO 13920-AE
 Machine components:
 ISO 2768-MK

Item	Quantity	Description	Reference
Designed by	Checked by	Approved by	Date
KGB	KGB		22.01.2015
Filename			Scale
C:\WH			
Title			Weight
DIMENSION DRAWING			kg
Drawing number			Edition
PINION K00 001			A
Sheet			1

Ensto Ervent Oy
 Kipinätel. FIN-06150 PORVOO
 Tel. +358-207-928600, ervent@ensto.com

Rev	Revision note	Date	Signature	Checked

Pingvin right hand

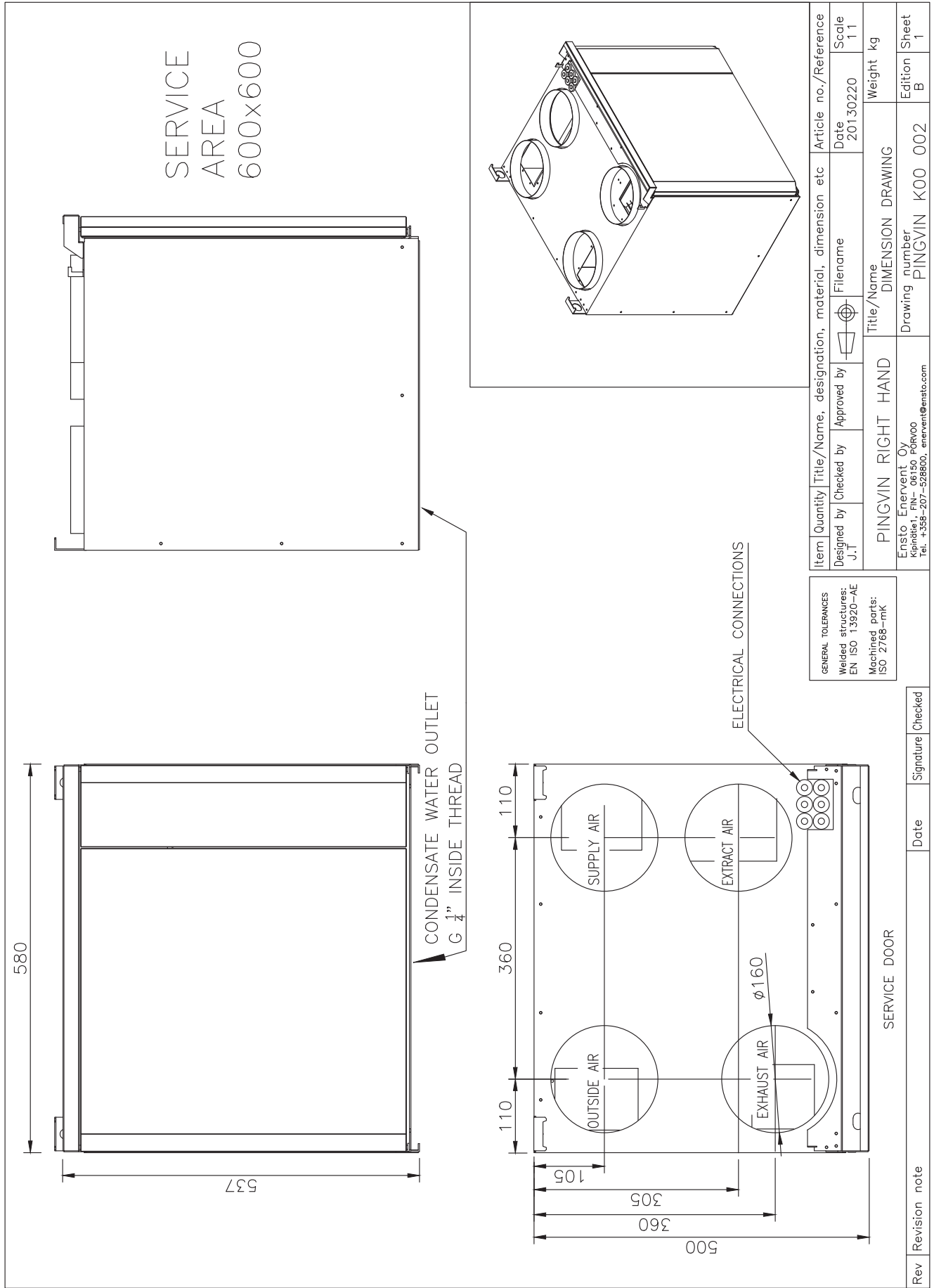

Pingvin XL right hand

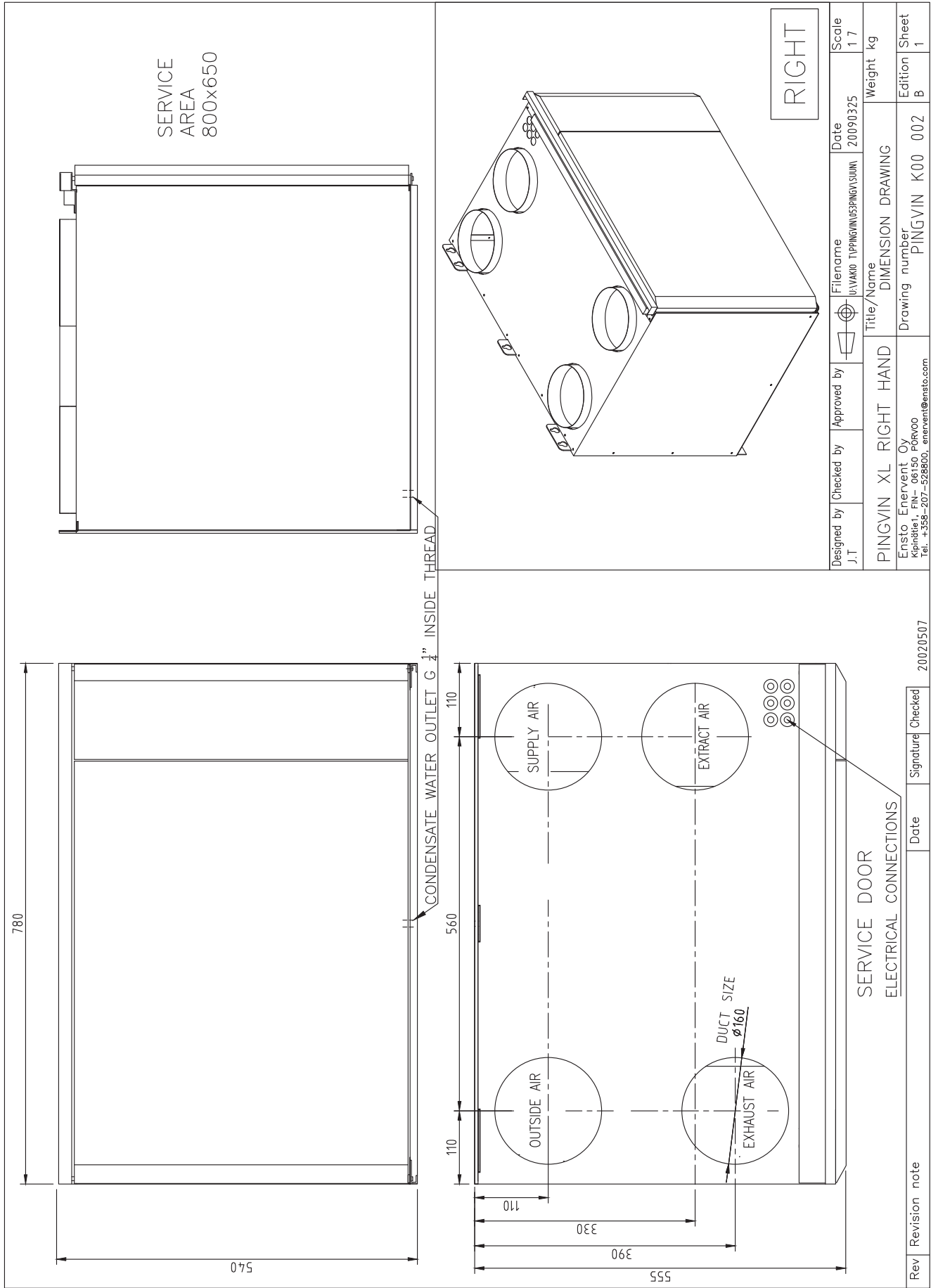

Designed by J.T	Checked by	Approved by	Filename U:\VAKIO TYPPING\IN\053PINGVIN\SUUN	Date 20090325	Scale 1:1
PINGVIN XL RIGHT HAND			Title/Name DIMENSION DRAWING	Weight kg	Edition B
Ernstö, Ervarent Oy Kajantie 1, FIN-00400, PORVOO Tel. +358-207-528800, ernstent@ernsto.com			Drawing number PINGVIN K00 002	Sheet 1	

Rev	Revision note	Date	Signature	Checked	20020507
-----	---------------	------	-----------	---------	----------

Pingvin XL left hand

780

540

560

CONDENSATE WATER OUTLET G 1/4" INSIDE THREAD

110

330

390

555

110

SUPPLY AIR

EXTRACT AIR

OUTSIDE AIR

EXHAUST AIR

DUCT SIZE ø160

SERVICE AREA
800x650

LEFT

Designed by J.T	Checked by	Approved by	Filename L:\VARD TYPING\N53PINGVIN\SDUM	Date 20090325	Scale 1:1
PINGVIN XL LEFT HAND			Title/Name DIMENSION DRAWING	Weight kg	Sheet 1
Ensto - Energvent Oy Mannerintie 10, Pori Fin. -055-207-528800, energvent@ensto.com			Drawing number PINGVIN XL 005	Edition A	Sheet 1

Rev	Revision note	Date	Signature	Checked	20020507
-----	---------------	------	-----------	---------	----------

Pelican

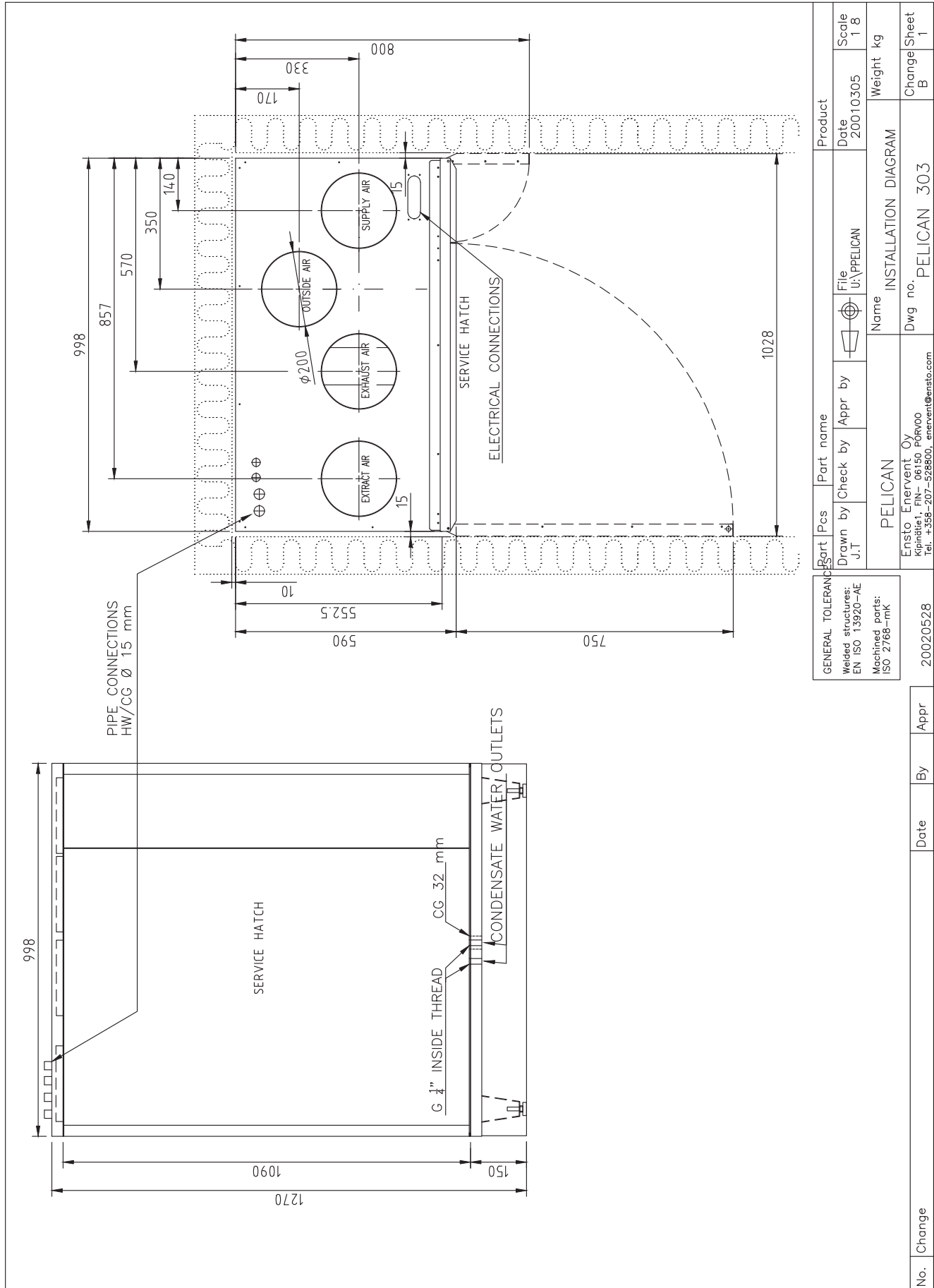

GENERAL TOLERANCES		Part		Pcs		Part name		Product	
Welded structures: EN ISO 13920-AE		Drawn by	Check by	Appr by	File	U:\PELICAN		Date	Scale
Machined parts: ISO 2768-mK		J.T					INSTALLATION DIAGRAM	20010305	1:8
20020528		PELICAN		Name		Dwg no.		Weight	Change
		Ensto, Enervent Oy Kipinäkatu 10 00180 FORVOO Tel. +358-207-528800, enervent@ensto.com		PELICAN 303		1028		kg	Sheet
No.		Change		Date		By		Appr	

Pegasos (XL) / Twintropic

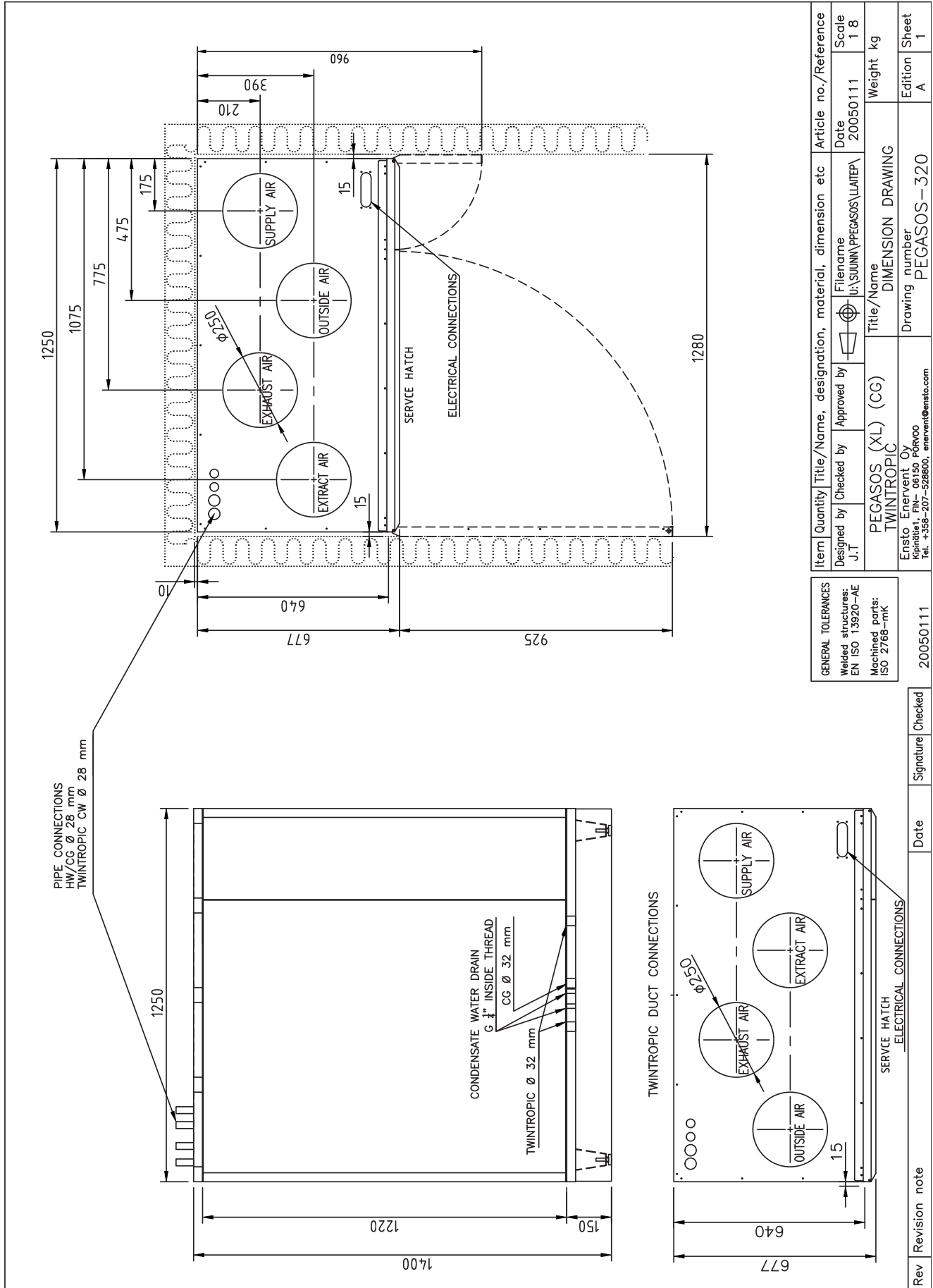

Item	Quantity	Title/Name, designation, material, dimension etc	Article no./Reference
Designed by	Checked by	Approved by	File name
J.T	J.T		U:\SUUNN\PEGASOS\LLATEPA
PEGASOS (XL) (CG) TWINTROPIC Title/Name DIMENSION DRAWING			Date 20050111 Scale 1:8 Weight kg Edition A Sheet 1
GENERAL TOLERANCES Welded structures: EN ISO 13920-AE Machined parts: ISO 2768-mK			Drawing number PEGASOS-320
Ensto Energyvent Oy Keskitalo, FIN-00515, Oulunkatu 1 Tel. +358-207-528800, energyvent@ensto.com			Article no./Reference 20050111
Rev	Revision note	Signature	Checked
			Date

Pallas

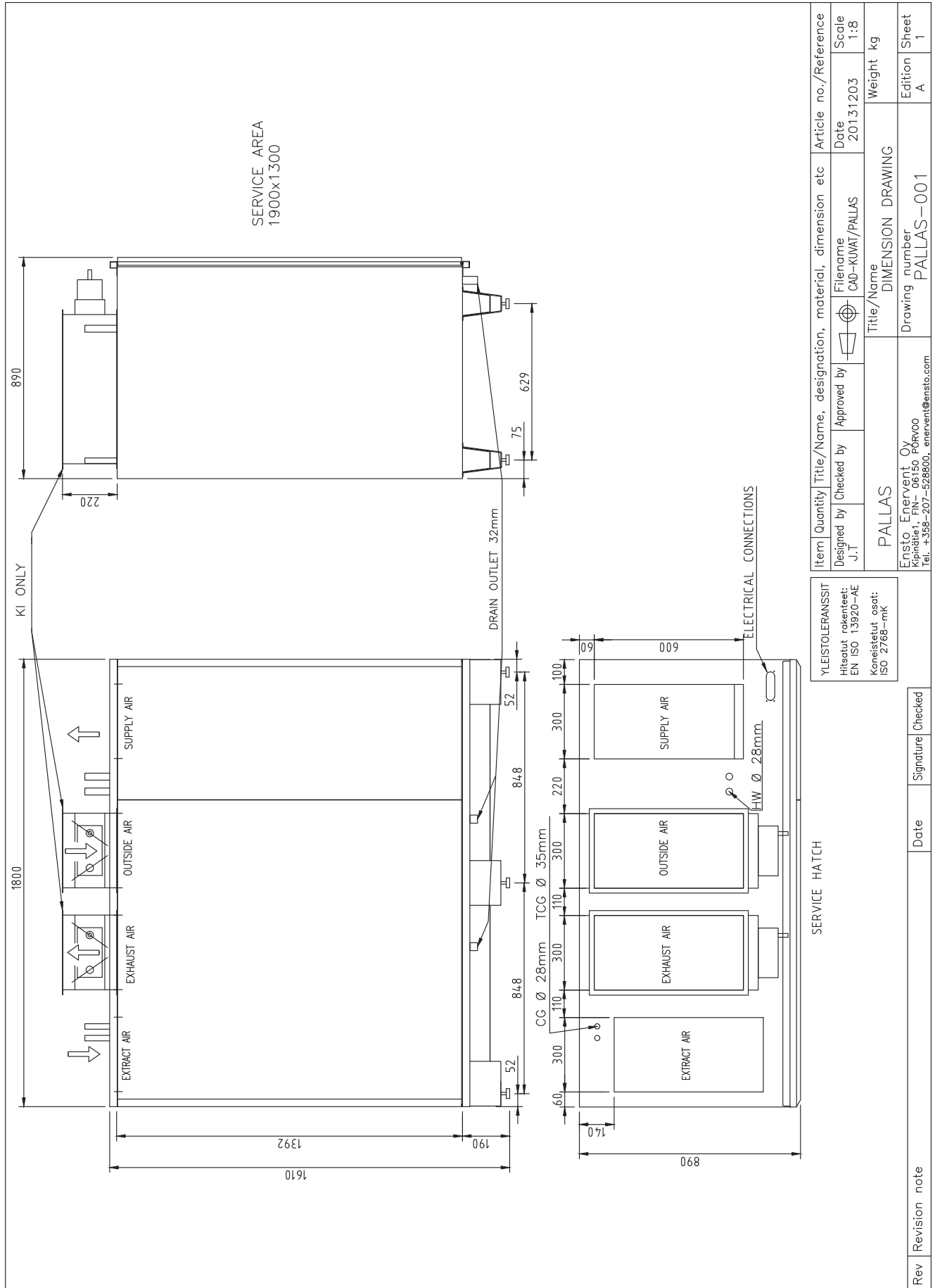

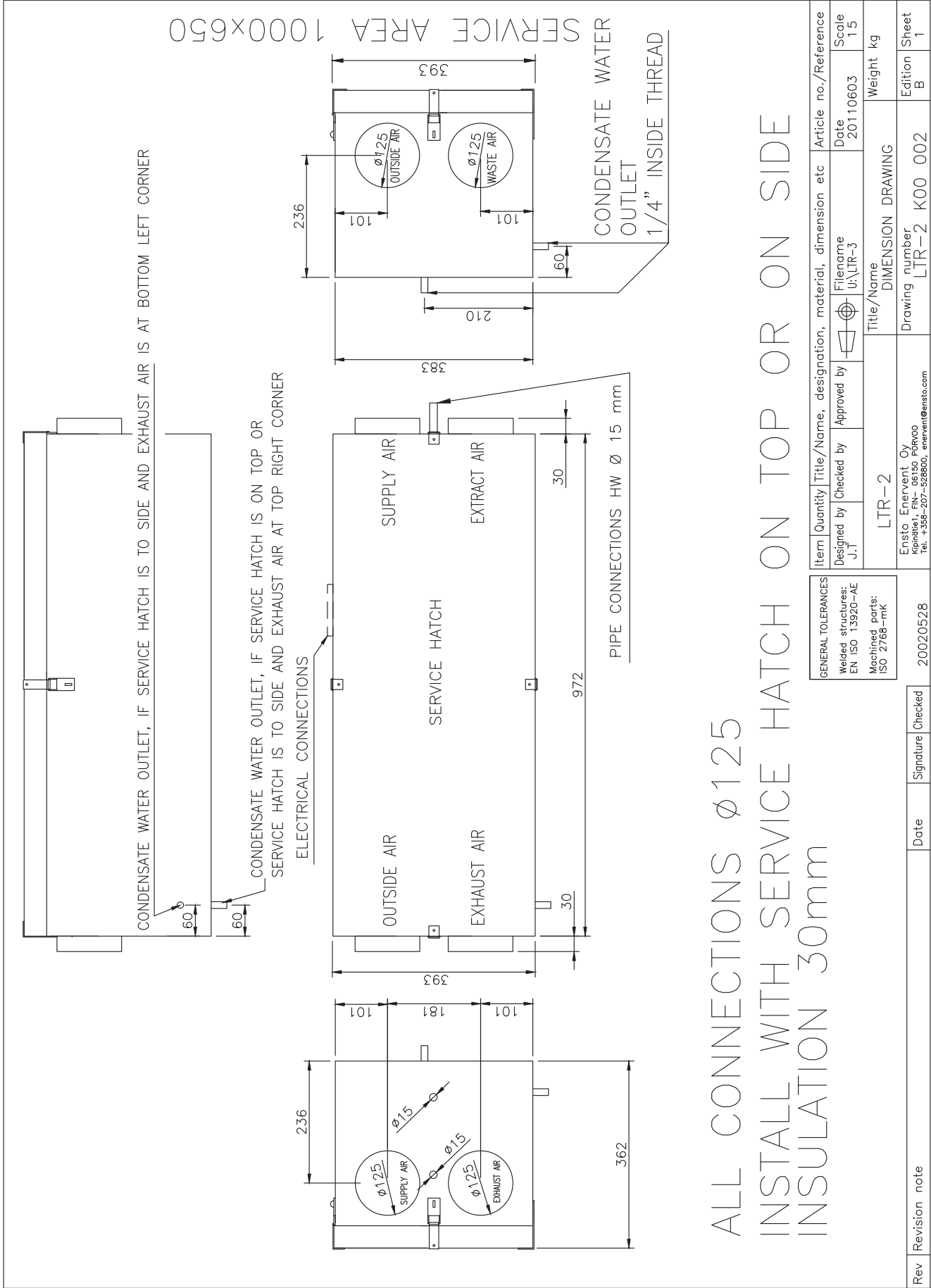

ALL CONNECTIONS Ø125
 INSTALL WITH SERVICE HATCH ON TOP OR ON SIDE
 INSULATION 30mm

GENERAL TOLERANCES Welded structures: EN ISO 13920-AE Machined parts: ISO 2768-mk	Item	Quantity	Title/Name, designation, material, dimension etc	Article no./Reference
	Designed by J.T	Checked by	Approved by	File name U:\LTR-3
	LTR-2			Title/Name DIMENSION DRAWING
	Ersto, Ervent Oy Kivimäentie 10 FIN-00010 Tel. +358-207-528800, ervent@ersto.com			Drawing number LTR-2 K00 002
20020528	Signature	Checked	Date	Revision note
				Weight kg
				Edition B
				Scale 1:5
				Sheet 1

LTR-3

SERVICE AREA 1000x650

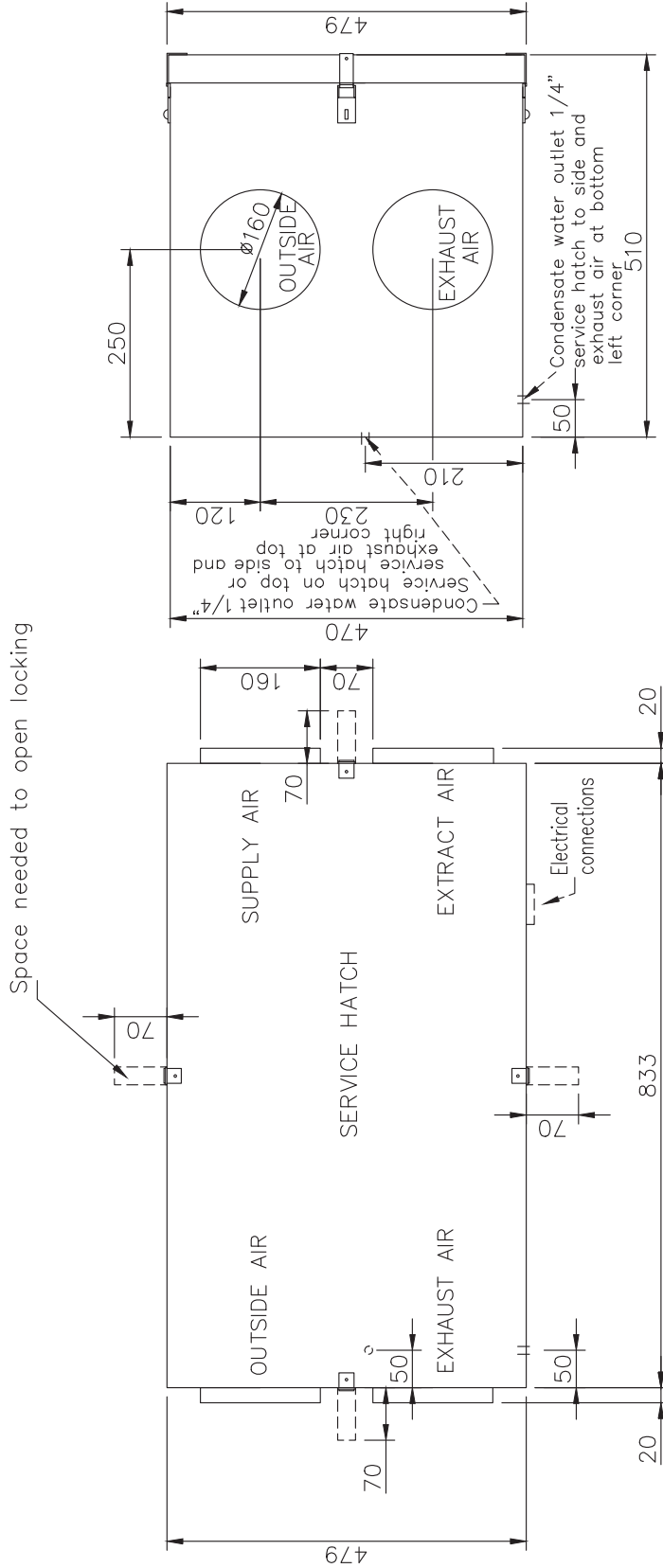

ALL CONNECTIONS $\phi 160$
 25mm INSULATION
 INSTALL WITH SERVICE HATCH ON TOP OR TO SIDE

No	Change	Date	By	Appr	Part Pcs		Part name		Product	
					LTR-3		DIMENSION DRAWING		Weight kg	
Ensto, Enervent Oy Kinnula, Finland, Pöytäkuo Tel. +358-207-528800, enervent@ensto.com					Dwg no		2,032,006		Change Sheet	
					J.T		File		Date 20100223 Scale	
					Condensate water outlet 1/4" service hatch on top or side and exhaust air at top right corner		t:\2\Small electric appliance\032LTR3\1:6		1:6	
					Condensate water outlet 1/4" service hatch on top or side and exhaust air at bottom left corner				D	
					Service hatch on top or side and exhaust air at top right corner				1	
					Service hatch on top or side and exhaust air at top right corner				D	

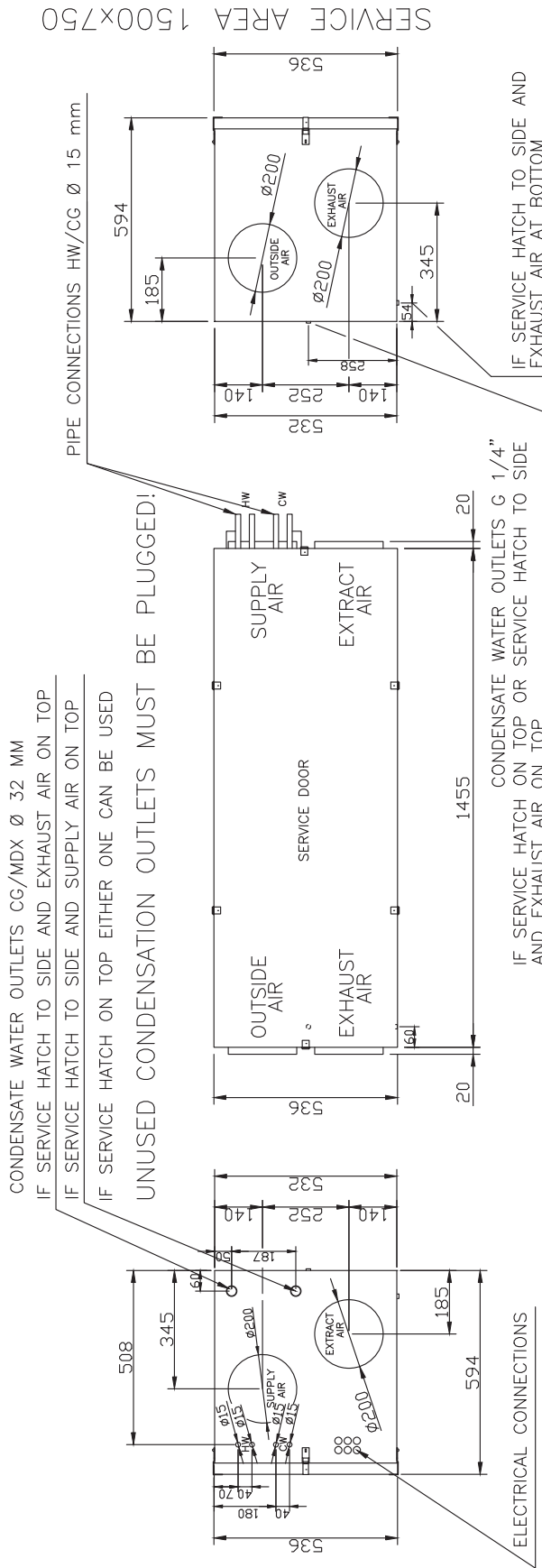

ALL CONNECTIONS Ø200
 INSTALL WITH SERVICE HATCH ON TOP OR ON SIDE
 INSULATION 30mm

Rev	Revision note	Date	Signature	Checked	TOLERANCES Welded components: EN ISO 13920-AE Machine components: ISO 2768-MK	Item Quantity Description LTR - 4 HW CW		Reference Title DIMENSION DRAWING		Drawing number LTR 4 - 003	Edition A	Sheet 1
	Designed by KGB	Checked by KGB	Approved by C:WH	Filename C:WH		Date 22.10.2014	Scale 1:1	Weight kg	Reference Date 22.10.2014	Title DIMENSION DRAWING	Drawing number LTR 4 - 003	Edition A

Ensto - Energiverk
 Kipinäntie 10, 00600
 Espoo, Finland
 Tel. +358-207-528800, energiverk@ensto.com

LTR-6 dimensional drawing 50 mm

SERVICE AREA 1400x800

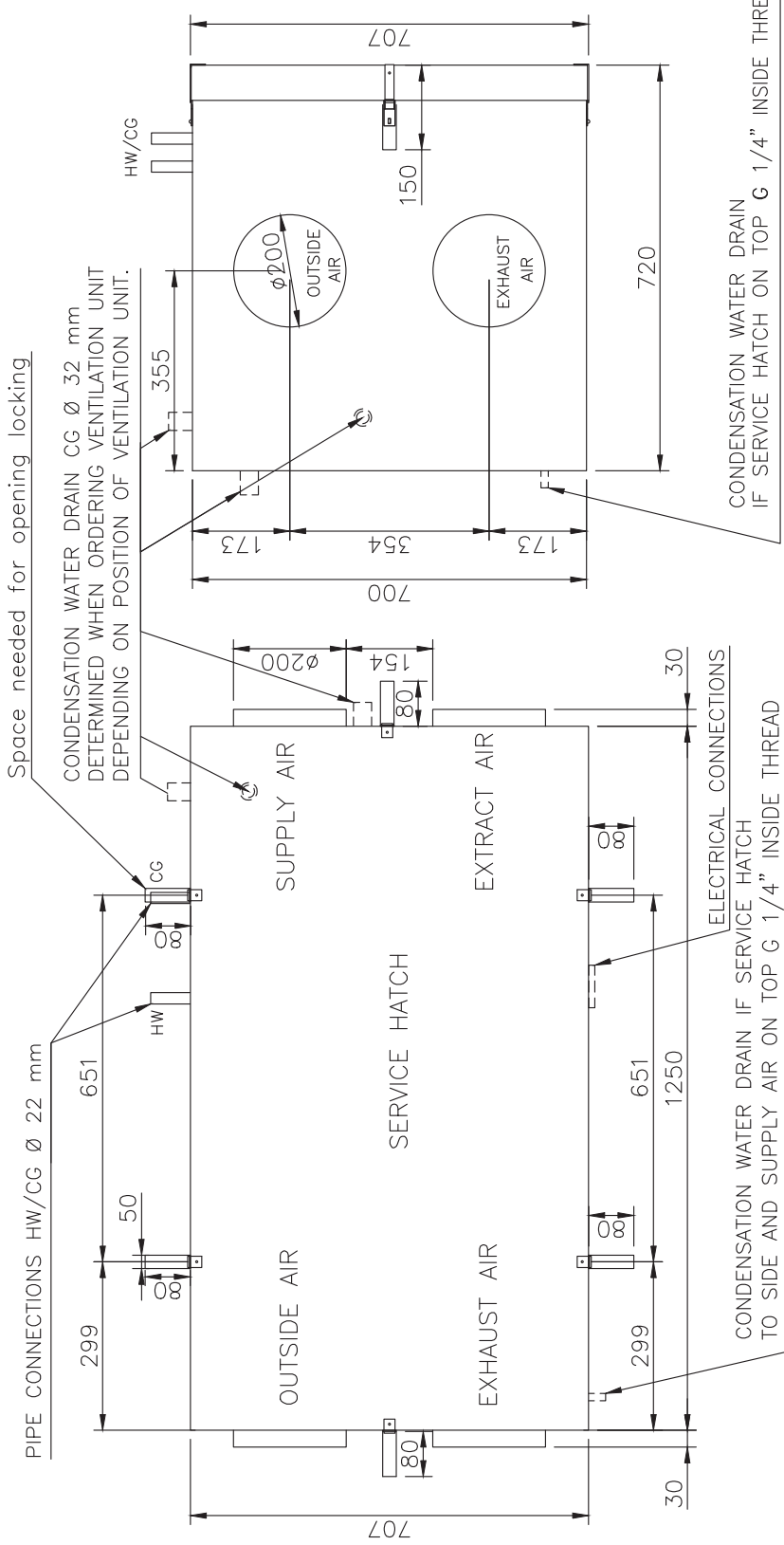

ALL CONNECTIONS $\phi 200$
INSULATION 50mm
INSTALL WITH SERVICE HATCH ON TOP OR TO SIDE

GENERAL TOLERANCES		Part Pcs		Part name		Product	
Welded structures: EN ISO 13920-AE		Drawn by	Check by	Appr by	File	Date	Scale
Machined parts: ISO 2768-mk		JT			t:\2 Small electric appliance\litr6	19970527	1:6
		LTR-6 50 mm ISOLATION				Name DIMENSION DRAWING	
		Ensto, Enervent Oy Tampere, Finland, P.O. Box Tel. +358-207-528800, enervent@ensto.com				Dwg no. 2,007,039	
No.	Change	Date	By	Appr			
					Weight kg		
					Change Sheet		
					A 1		

LTR-7 (XL)

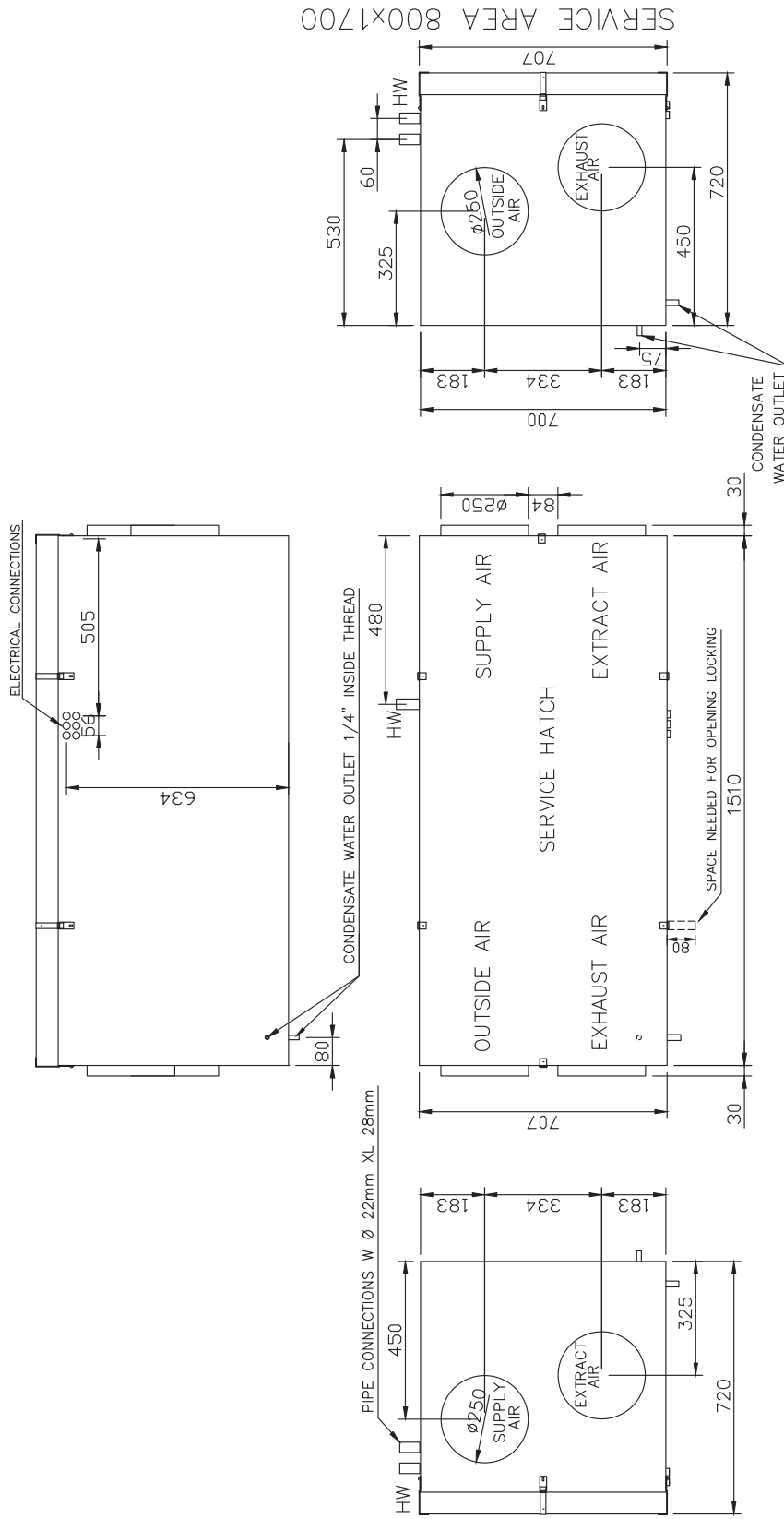

SERVICE AREA 800x1700

ALL CONNECTIONS $\phi 250$
 50mm INSULATION PV-IPL (mineral wool)
 INSTALL WITH SERVICE HATCH ON TOP OR TO THE SIDE WITH SUPPLY AIR ON TOP

GENERAL TOLERANCES		Part		Pcs		Part name		Product	
Welded structures: EN ISO 13920-AE		Drawn by	Check by	Appr by	File	Date	Scale		Sheet
Machined parts: ISO 2768-mk		J.T			U:\AK101\LTR-S\007\LTR7	20030526	1 8		1
		LTR-7 (XL)		Name		DIMENSION DRAWING		Weight kg	
				Ensto, Enervent Oy		Dwg no.		Change	
				Espinaite, J.T. - 00500 Pdraco		LTR 7-001		B	
				Tel. +358-207-328801, enervent@ensto.com					
No.	Change	By	Appr	Date	20020822				

WIRING DIAGRAMS

EN

MD basic external connections

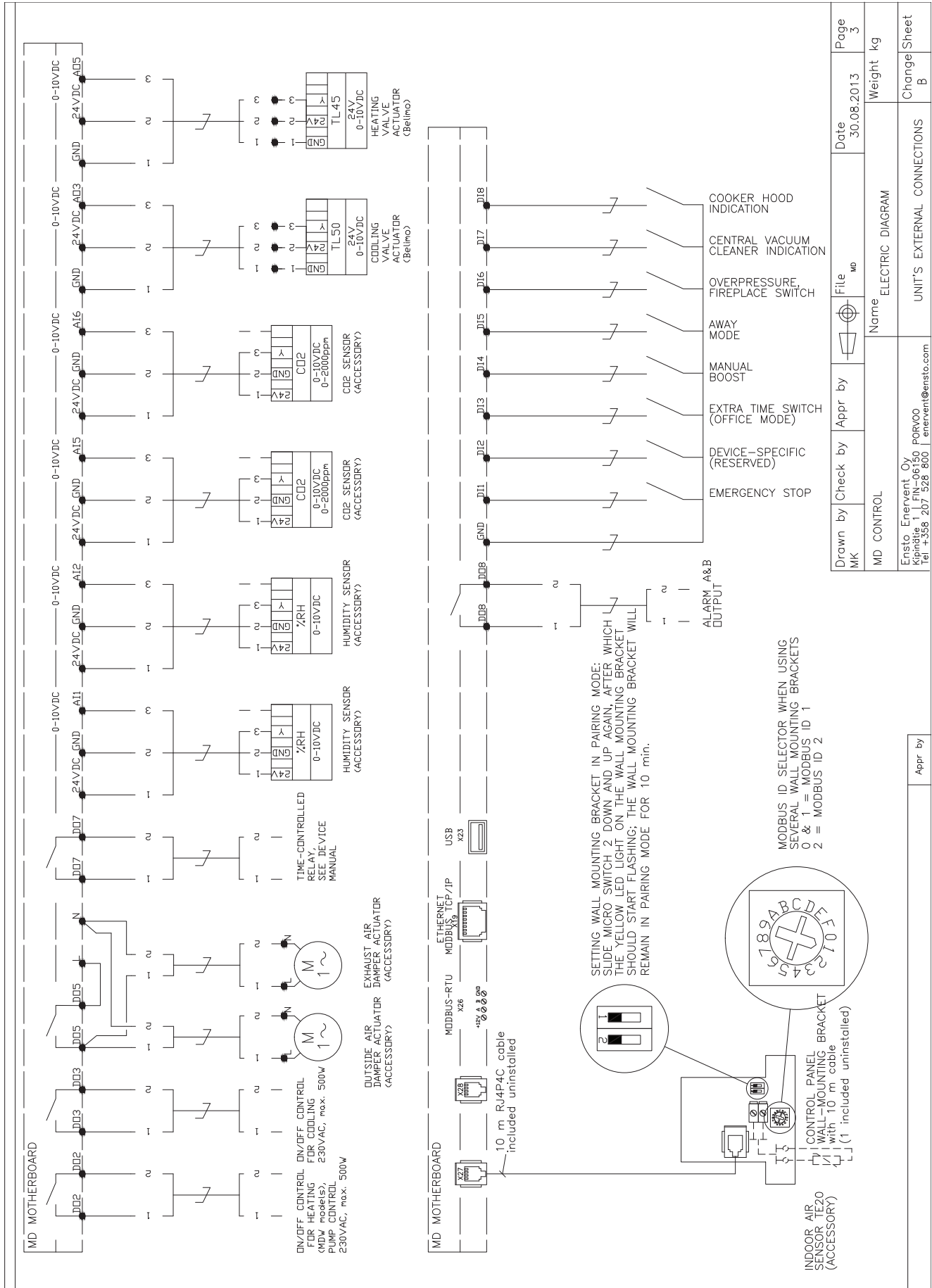

Drawn by	Check by	Appr. by	Date	Page
MK			30.08.2013	3
Name			File	Weight
MD CONTROL			MD	kg
Ersto, Ervent Oy, Pori 80000, Finland Tel: +358 207 928 800 ervent@ersto.com			ELECTRIC DIAGRAM	
			UNIT'S EXTERNAL CONNECTIONS	
			Change	Sheet
			B	

MD HRC connection

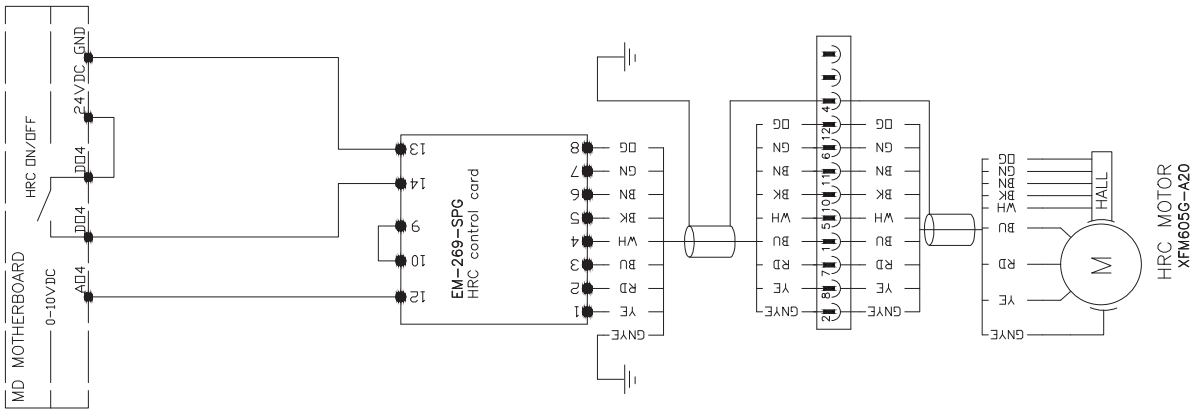

- WIRE COLOURS
- BLACK - BK
 - BROWN - BN
 - RED - RD
 - ORANGE - OG
 - YELLOW - YE
 - GREEN - GN
 - BLUE - BU
 - GREY - GY
 - WHITE - WH

Drawn by MK	Check by	Appr by	File MD	Appr by 30.08.2013	Page 2
MD Control HRC schematic	Name ELECTRIC DIAGRAM			Weight kg	Change A
Ensto Enervent Oy Kipinätie 1, FIN-06150 PORVOO Tel. +358 207 328 600 enervent@ensto.com			AHU UNIT'S INTERNAL CONNECTIONS		Sheet A 1

Appr by

MD electrical after-heater 1~

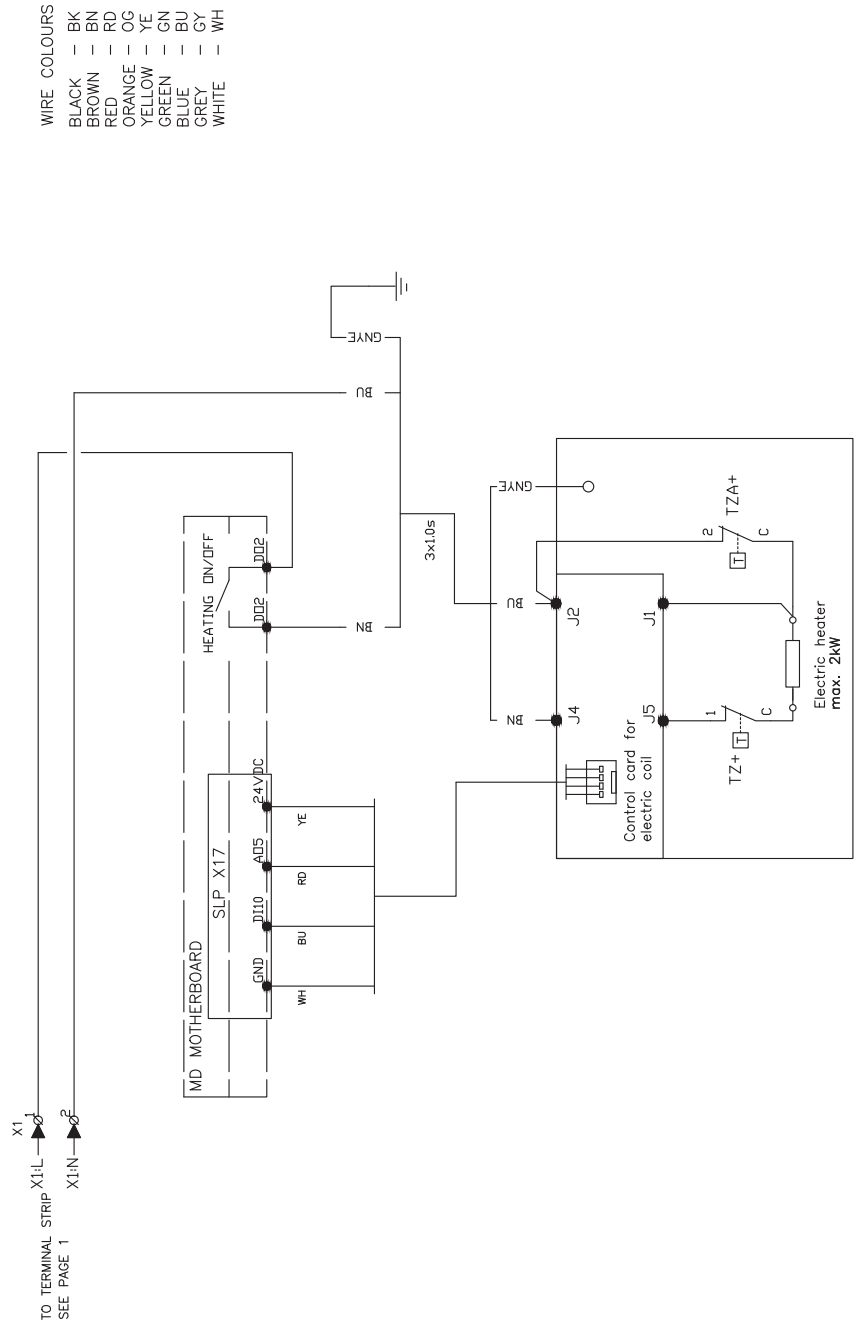

Drawn by MK	Check by	Appr by	File MD	Date 30.08.2013	Page 2
MD Control Electric heater ≤ 2 kW connections			Name ELECTRIC DIAGRAM	Weight kg	Change B
Ensto, Enervent Oy Kivimäenkatu 8 01300 Vammala Tel. +358 207 328 800 enervent@ensto.com			UNIT'S INTERNAL CONNECTIONS		

Appr by

MD electrical after-heater 2~

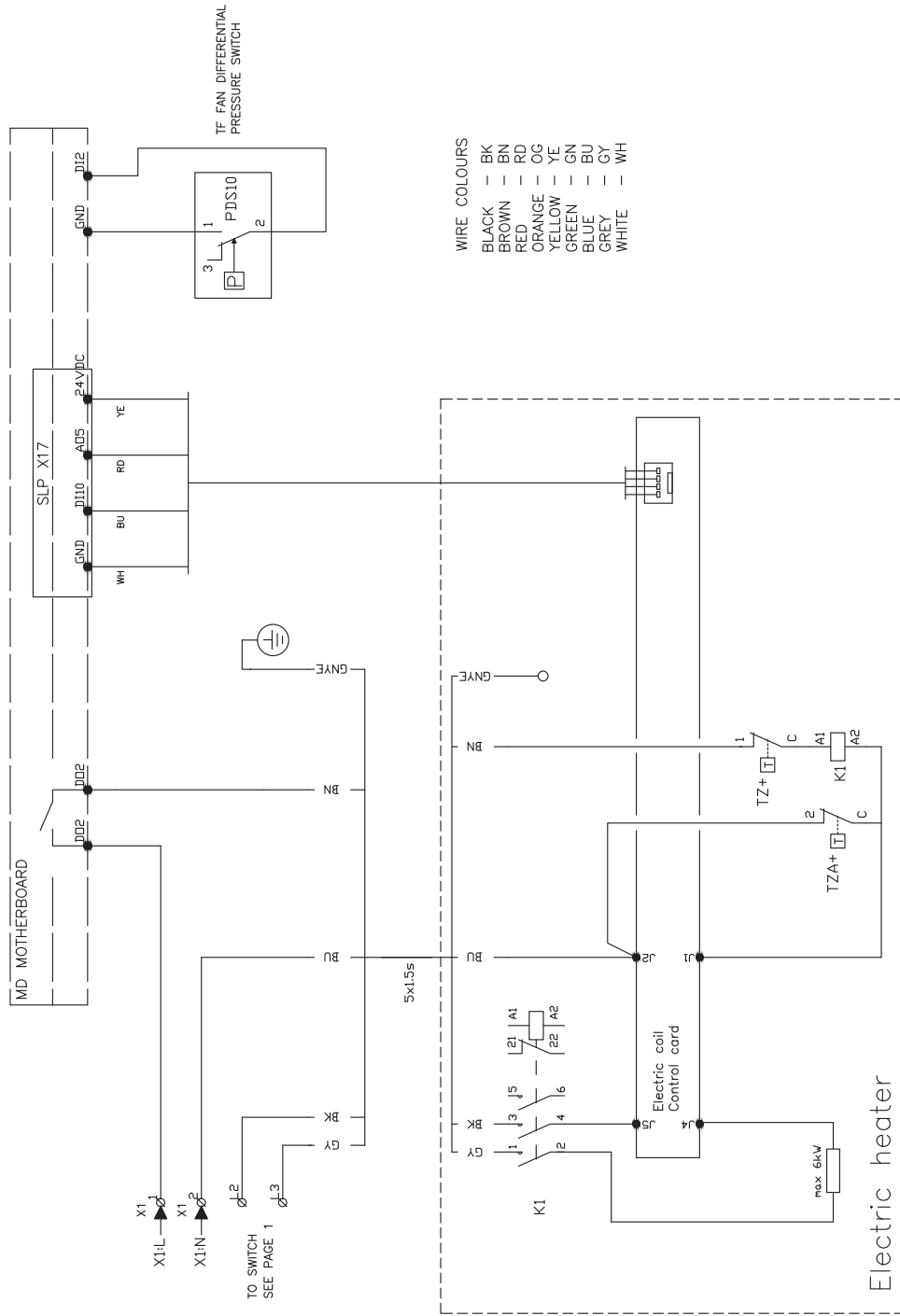

Drawn by	Check by	Appr by	File	Date	Page
MK			mo	17.01.2014	2
Name			ELECTRIC DIAGRAM		
MD CONTROL			ELECTRIC DIAGRAM		
Electric coil > 2kW connections			Weight kg		
Ensto Enervent Oy			Change Sheet		
Kipinätie 1 FIN-06150			D		
Tel +358 207 528 800 enervent@ensto.com			2		

Appr by

MD PREHEATER ELECTRIC DIAGRAMS (CHG/AGH)

MD water-circulating preheater/precooler connections

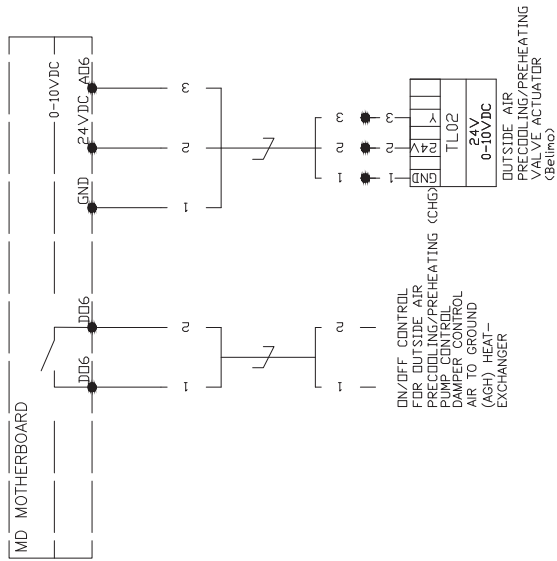

Drawn by MK	Check by	Appr by	File MD	Date 02.09.2013	Page 3
MD control CHG/AGH CONNECTIONS	Name ELECTRIC DIAGRAM		Weight kg		
Ensto Enervent Oy Kipinätie 1, FIN-06150 PORVOO Tel. +358 207 328 800 enervent@ensto.com			AHU	UNIT'S EXTERNAL CONNECTIONS	Change A
Appr by					Sheet 2

MD electrical preheater 1~

WIRE COLOURS
 BLACK — BK
 BROWN — BN
 RED — RD
 ORANGE — OC
 YELLOW — YE
 GREEN — GN
 BLUE — BU
 GREY — GY
 WHITE — WH

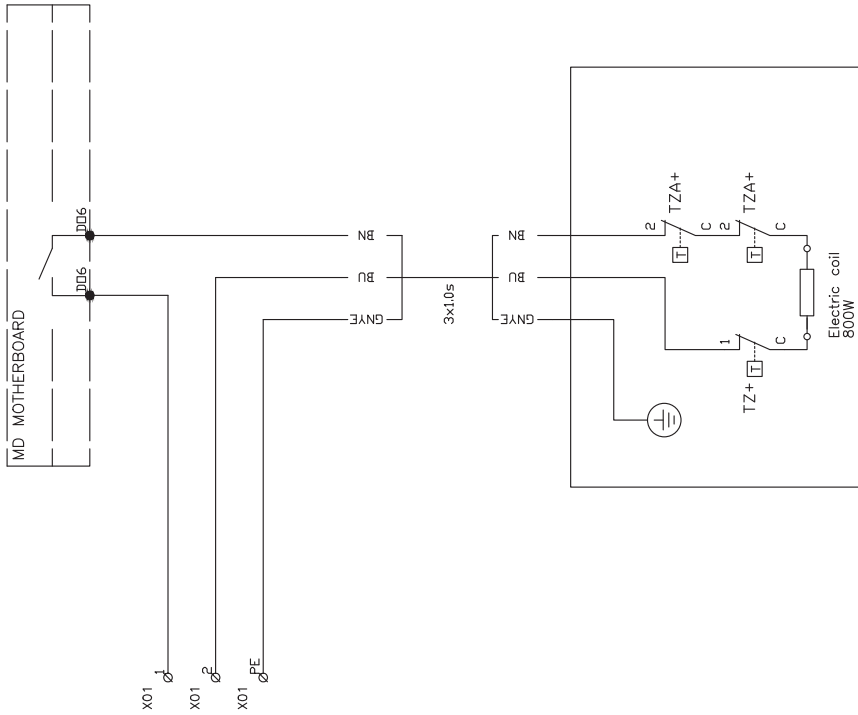

Drawn by JP	Check by	Appr by	File md	Date 24.09.2014	Page 2
MD CONTROL Electric preheater, THERM—controlled			Name ELECTRIC DIAGRAM	Weight kg	Change Sheet
Ensto Enervent Oy Kipinätie 1 FIN-06150 PORVOO Tel +358 207 528 800 enervent@ensto.com			UNIT'S INTERNAL CONNECTIONS		3

Appr. by

MD electrical preheater 2~

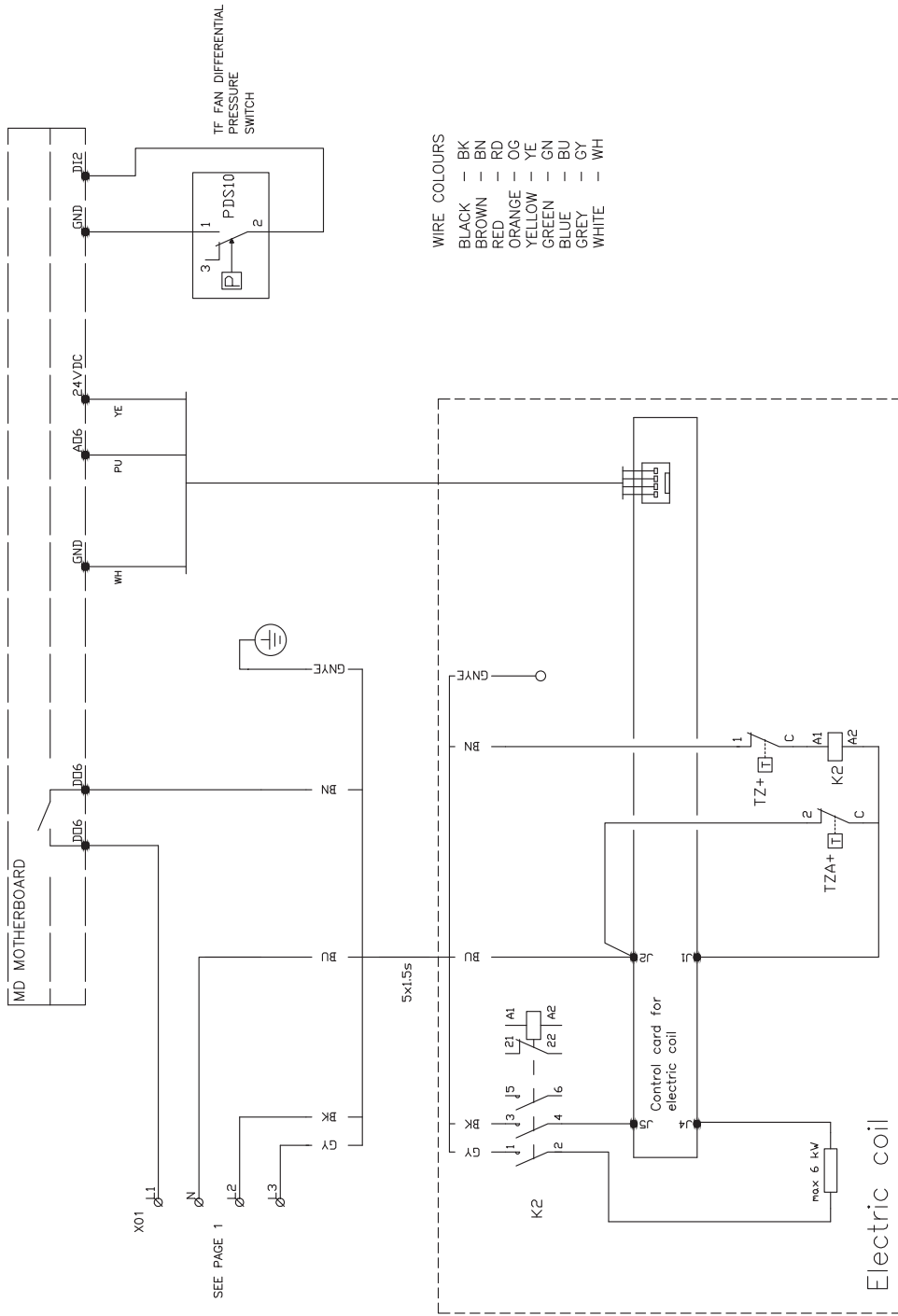

Drawn by MK	Check by	Appr by	File MD	Date 16.01.2014	Page 2
Name ELECTRIC DIAGRAM			Weight kg		
MD CONTROL Electric preheater > 2 kW			Change B		
Ensto Enervent Oy Kipinäkatu 16 18100 Tel: +358 207 528 800 enervent@ensto.com			Sheet 3		

Appr by

MD TCG with absolute humidity logging function

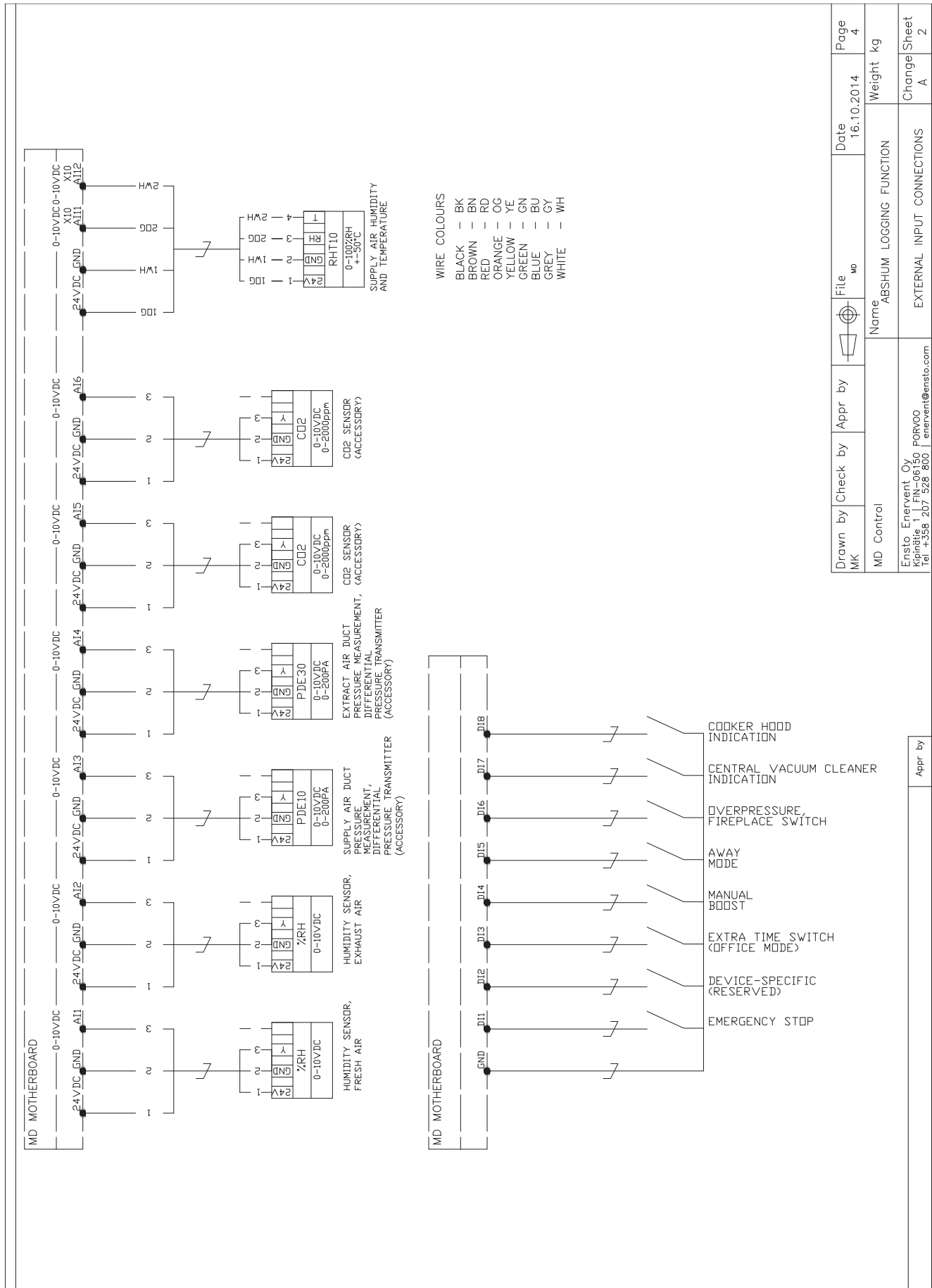

Drawn by MK	Check by	Appr by	File md	Date 16.10.2014	Page 4
MD Control	Name ABSHUM LOGGING FUNCTION			Weight kg	Change A
Ersto, Ervennt, Oy Kipnnt, 86400 POrV000 Tel: +358 207 328 800 ervent@ersto.com			EXTERNAL INPUT CONNECTIONS		
				Sheet 2	

MD Pallas HRC and electrical after-heater connections

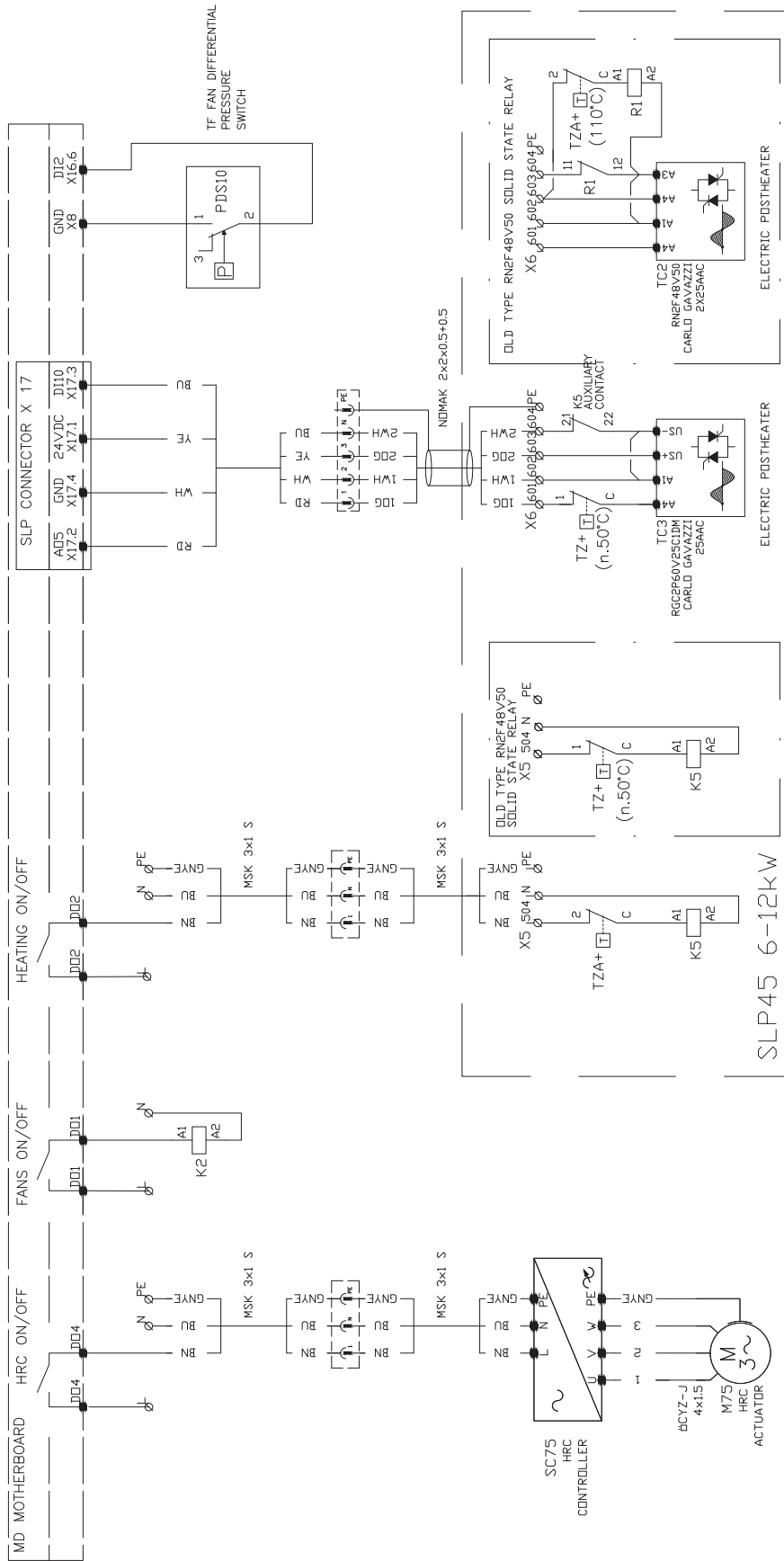

- WIRE COLOURS
- BLACK — BK
 - BROWN — BN
 - RED — RD
 - ORANGE — OG
 - YELLOW — YE
 - GREEN — GN
 - BLUE — BU
 - GREY — GY
 - WHITE — WH

Drawn by JP	Kontrolliered Appr by	File MD	Date 24.03.2015	Page 2
MD CONTROL HRC AND EHC CONTROL		Name UNIT'S INTERNAL CONNECTIONS	Weight kg	
		AHU PALLAS	Change B	Sheet 1
Appr by				

MD Pallas fan and electrical after-heater power supply

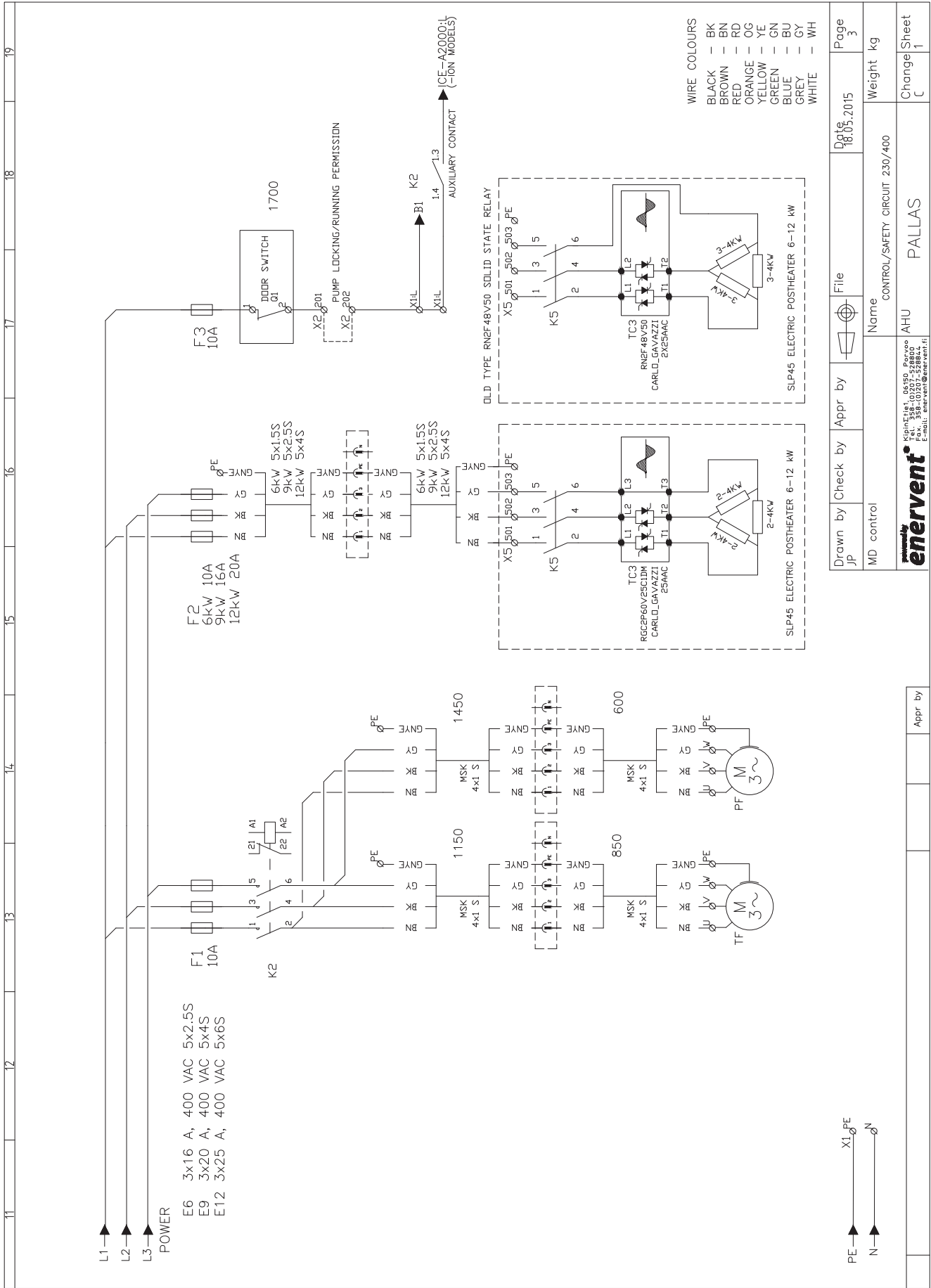

Drawn by jp	Check by MD control	Appr by	File 	Date 18.05.2015	Page 3
Name CONTROL/SAFETY CIRCUIT 230/400			Weight kg		
AHU PALLAS			Change c 1		
Kinnaird Ltd. 05455 558-10257-52800 Fax: 358-10250-652884.4 E-mail: enervent@enervent.fi			Sheet 1		

TWIN TROPIC DIFFERING ELECTRIC DIAGRAMS

MD TwinTropic external connections

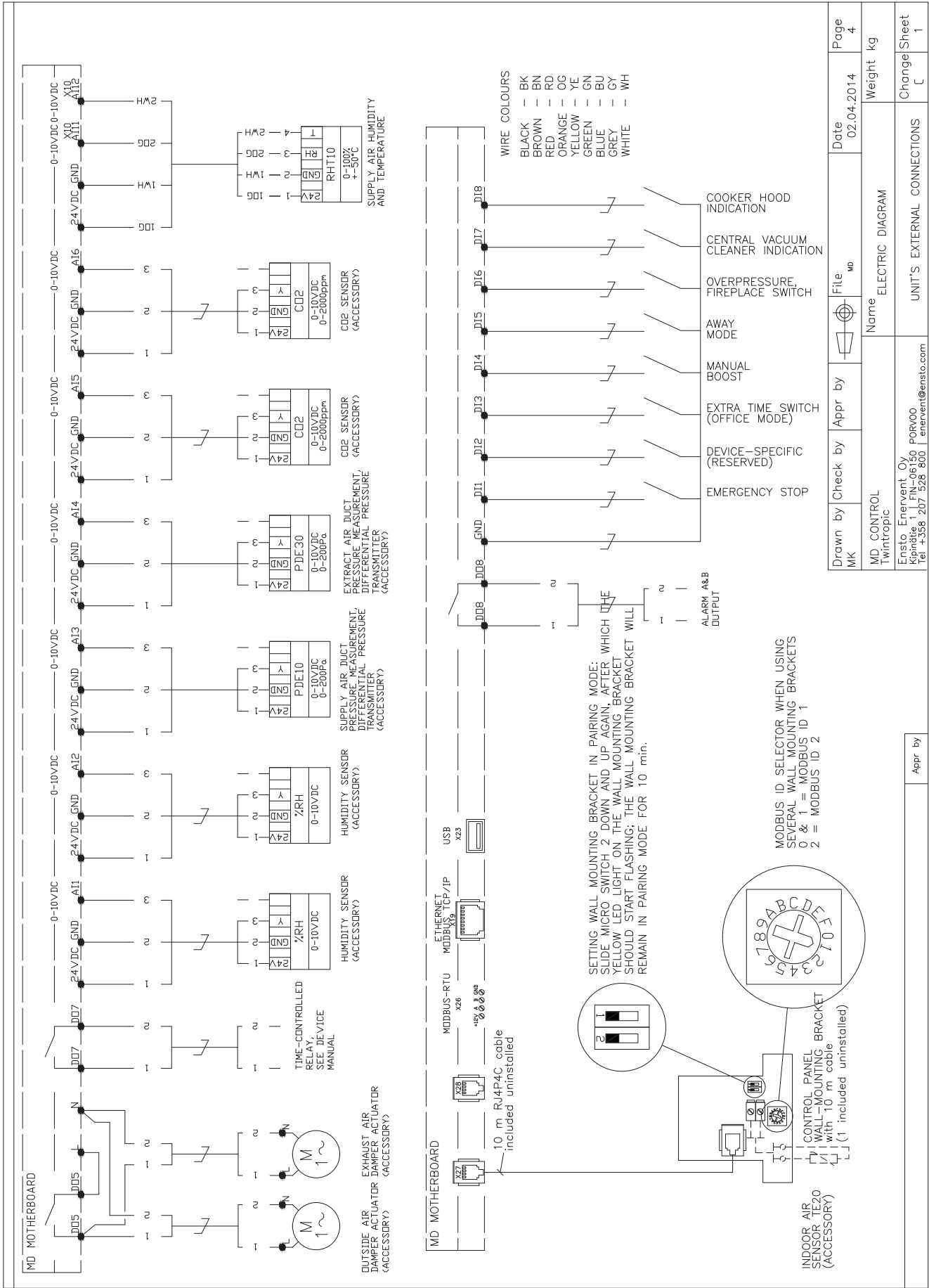

MD TwinTropic HRC connections

- WIRE COLOURS
 BLACK — BK
 BROWN — BN
 RED — RD
 ORANGE — OG
 YELLOW — YE
 GREEN — GN
 BLUE — BU
 GREY — GY
 WHITE — WH

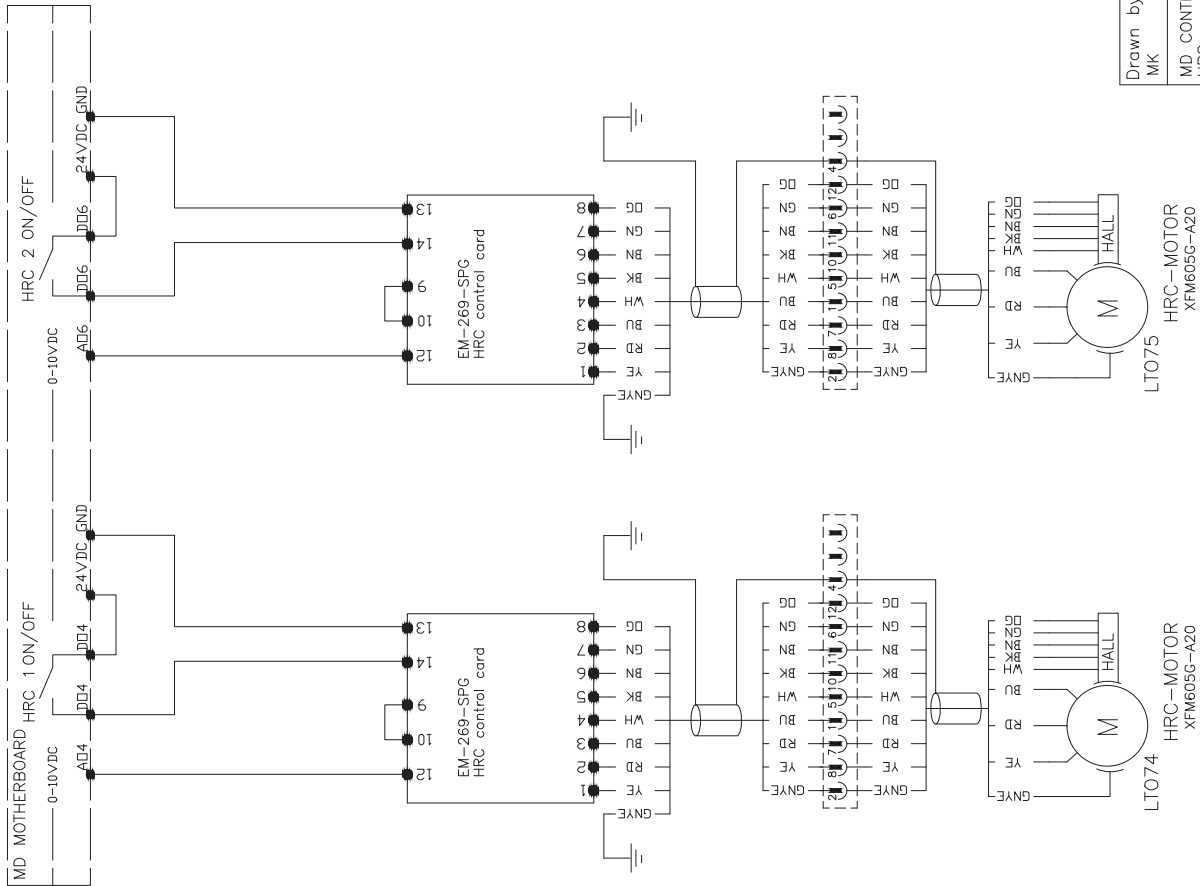

Drawn by MK	Check by	Appr by	File mb	Date 09.01.2014	Page 2
Name ELECTRIC DIAGRAM			Weight kg		
MD CONTROL HRC connections, Twin Tropic			UNIT'S INTERNAL CONNECTIONS		
Ensto Enervent Oy Kipinäkatu 6 18100 Tel: +358 207 328 800 enervent@ensto.com			Change Sheet A		

Appr by

MD TwinTropic water-circulating cooling connections

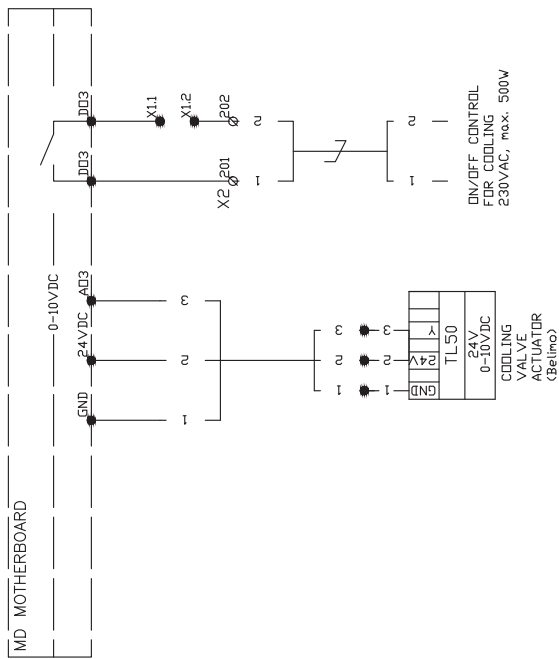

⌋ = ON SITE WIRING AND CONNECTION (EC)

Drawn by MK	Check by	Appr by	File MP	Date 02.04.2014	Page 3
MD CONTROL Twin Tropic CW(-E)			Name ELECTRIC DIAGRAM	Weight kg	Change C
Ensto, Ervent Oy Puhokatu 9 00100 Helsinki Tel: +358 207 528 800 ervent@ensto.com			INTERNAL/EXTERNAL CONNECTIONS		Sheet 1

Appr by

MISCELLANEOUS ELECTRICAL CONNECTIONS

MD cooker hood and central vacuum cleaner indication connections

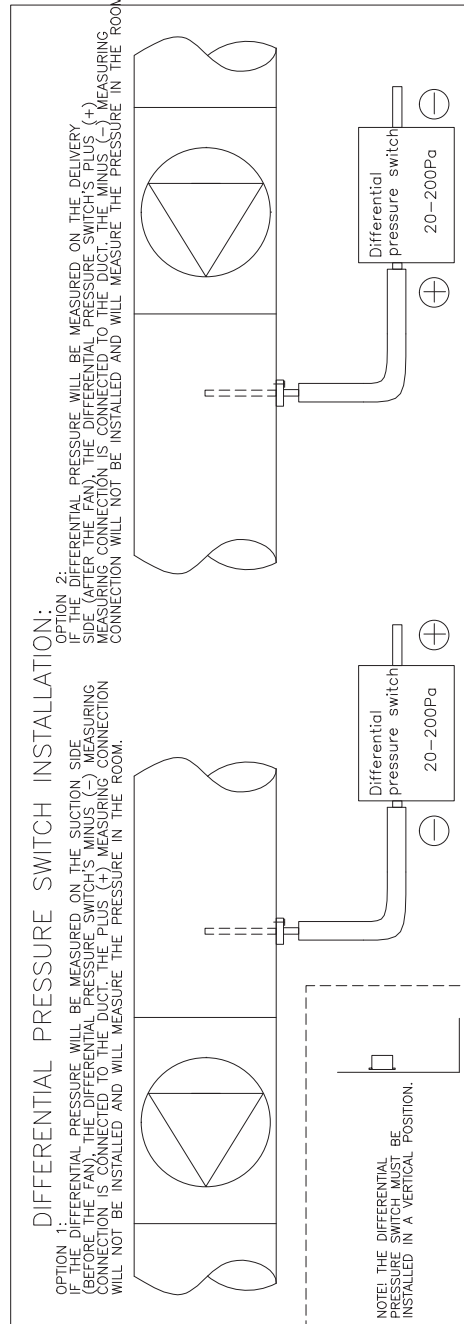
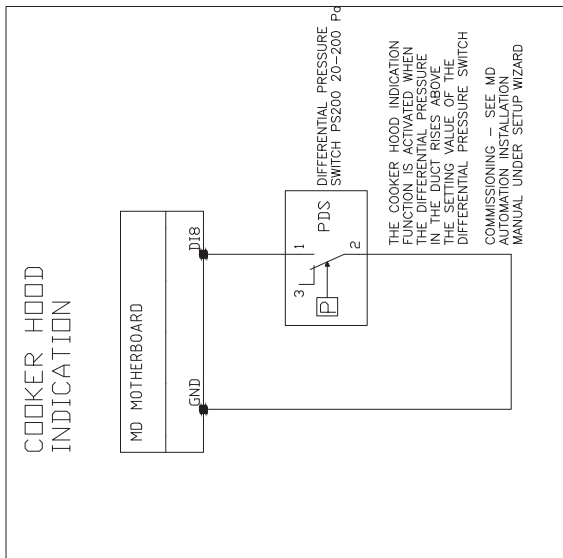
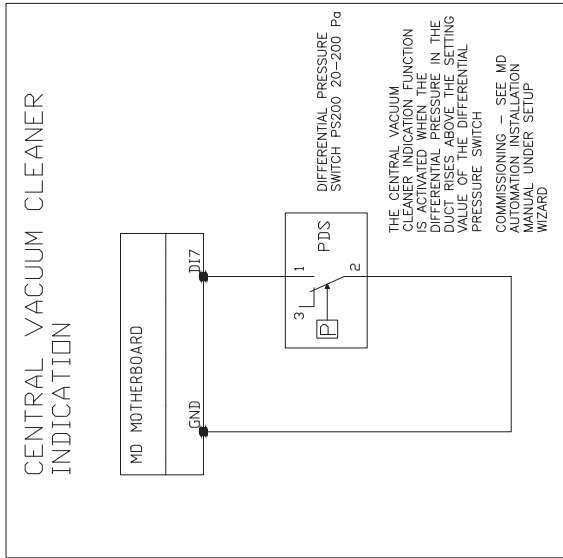

Drawn by MK	Check by	Appr by	File	Date 25.11.2013	Page 1
MD CONTROL Cooker hood and central vacuum cleaner indication			Nome	ELECTRIC DIAGRAM	Weight kg
Ensto, Ervent Oy Puhuriplaza 1 00100 181-1356 207 528 800 ervent@ensto.com			AHU		Change Sheet A

Appr by

MD duct pressure connection

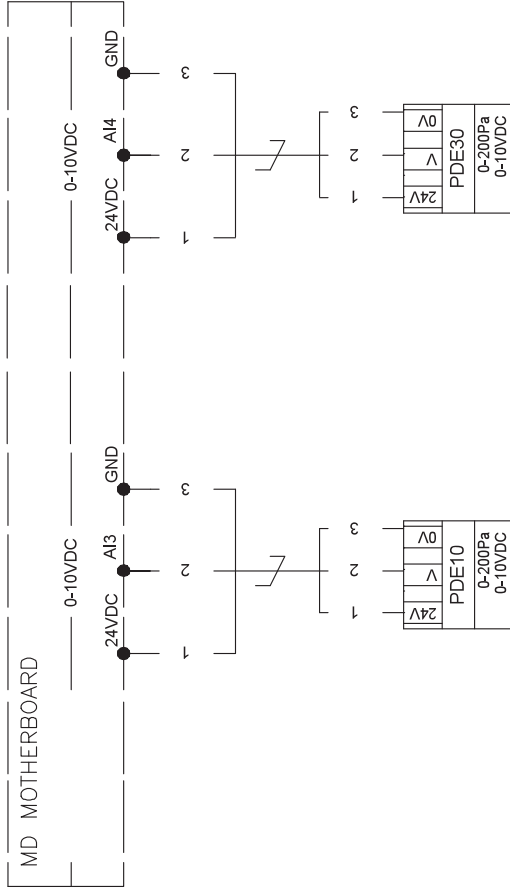

SUPPLY AIR DUCT PRESSURE MEASUREMENT, DIFFERENTIAL PRESSURE TRANSMITTER

EXTRACT AIR DUCT PRESSURE MEASUREMENT, DIFFERENTIAL PRESSURE TRANSMITTER

Drawn by MK	Check by	Appr by	File KANAKPANE	Date 12.12.2013	Page 1
MD CONTROL DIFFERENTIAL PRESSURE TRANSMITTER CONNECTION			Name ELECTRIC DIAGRAM		
Ensto Enervent Oy Kivimäenkatu 1 FIN-06150 PORVOO Tel. +358 207 328 800 enervent@ensto.com			AHU DUCT PRESSURE		
				Weight kg	Change Sheet A

Appr by

MD duct pressure installation

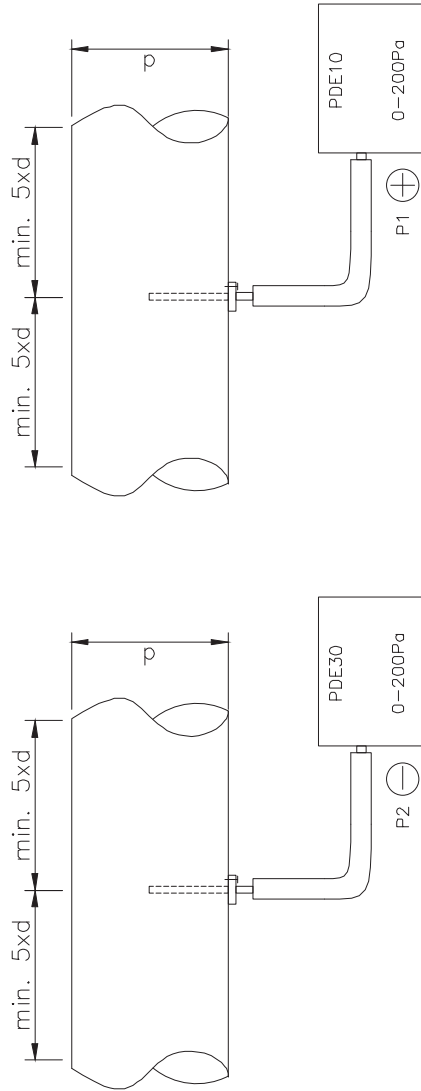
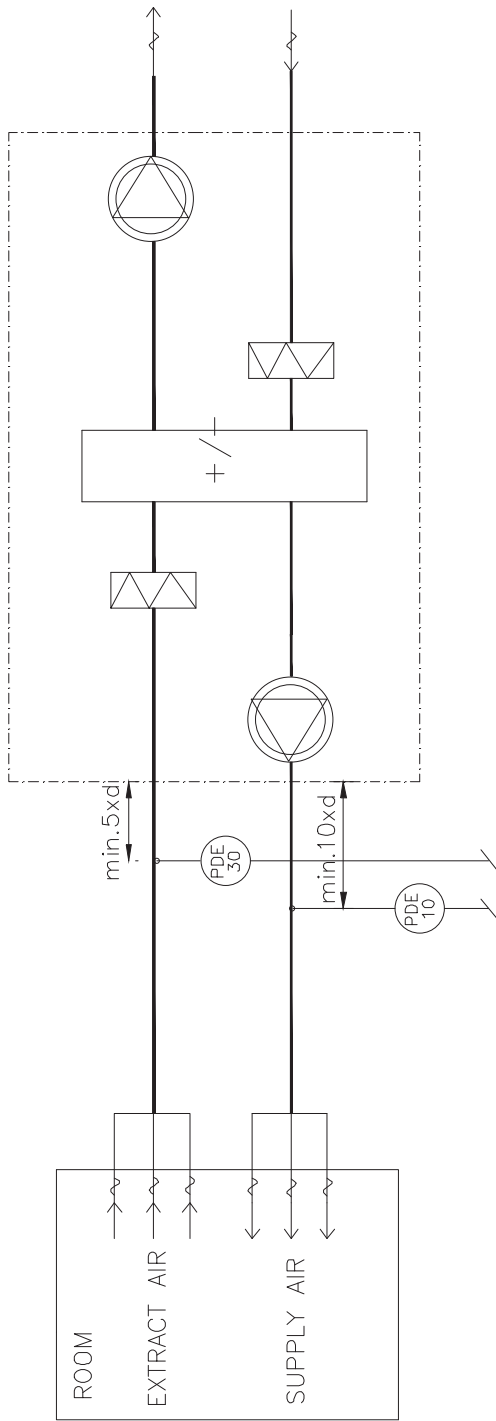

Drawn by	Check by	Appr by	File	Date	Page
MK				12.12.2013	
Name			Weight kg		
DUCT PRESSURE MEASUREMENT			Change Sheet		
AHU			A		
Ensto, Enervent Oy Kipinätie 1, PL 06150 PORVOO Tel. +358 207 328 800 enervent@ensto.com			1		

Appr by

MD filter guard connection

WIRE COLOURS
 BLACK — BK
 BROWN — BN
 RED — RD
 ORANGE — OG
 YELLOW — YE
 GREEN — GN
 BLUE — BU
 GREY — GY
 WHITE — WH

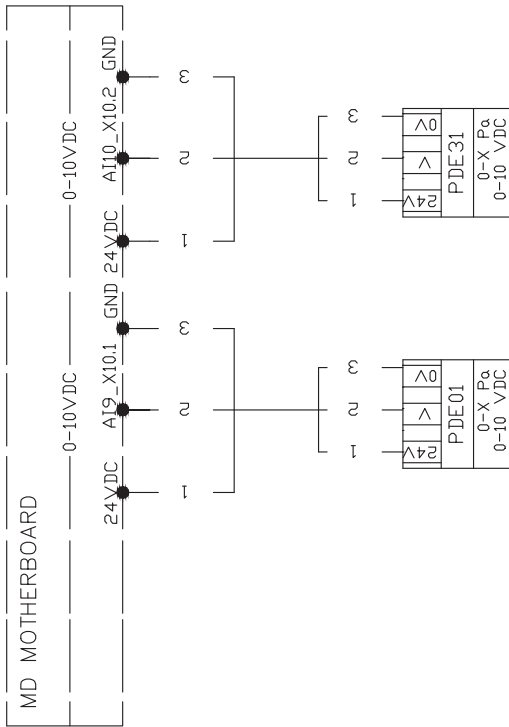

SUPPLY AIR FILTER
 PRESSURE MEASUREMENT,
 DIFFERENTIAL PRESSURE
 TRANSMITTER

EXTRACT AIR FILTER
 PRESSURE MEASUREMENT,
 DIFFERENTIAL PRESSURE
 TRANSMITTER

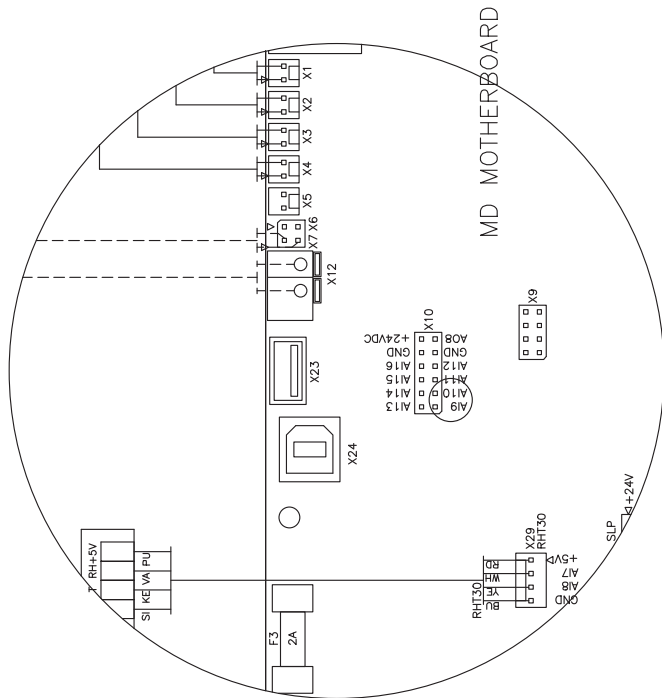

Drawn by MK	Check by	Appr by	File Suodinnvanti	Date 28.05.2014	Page 1
Name ELECTRIC DIAGRAM			Weight kg		
Name DIFFERENTIAL PRESSURE TRANSMITTER CONNECTION			Change C		
Ersto: Ernent Oy Puhelin: 09 8660 800 Faksi: 09 8660 800 Tiedot: 207 528 800 erivent@erasto.com			Sheet FILTER GUARD		

Appr by

PRINCIPAL DIAGRAMS

MD HW principle scheme

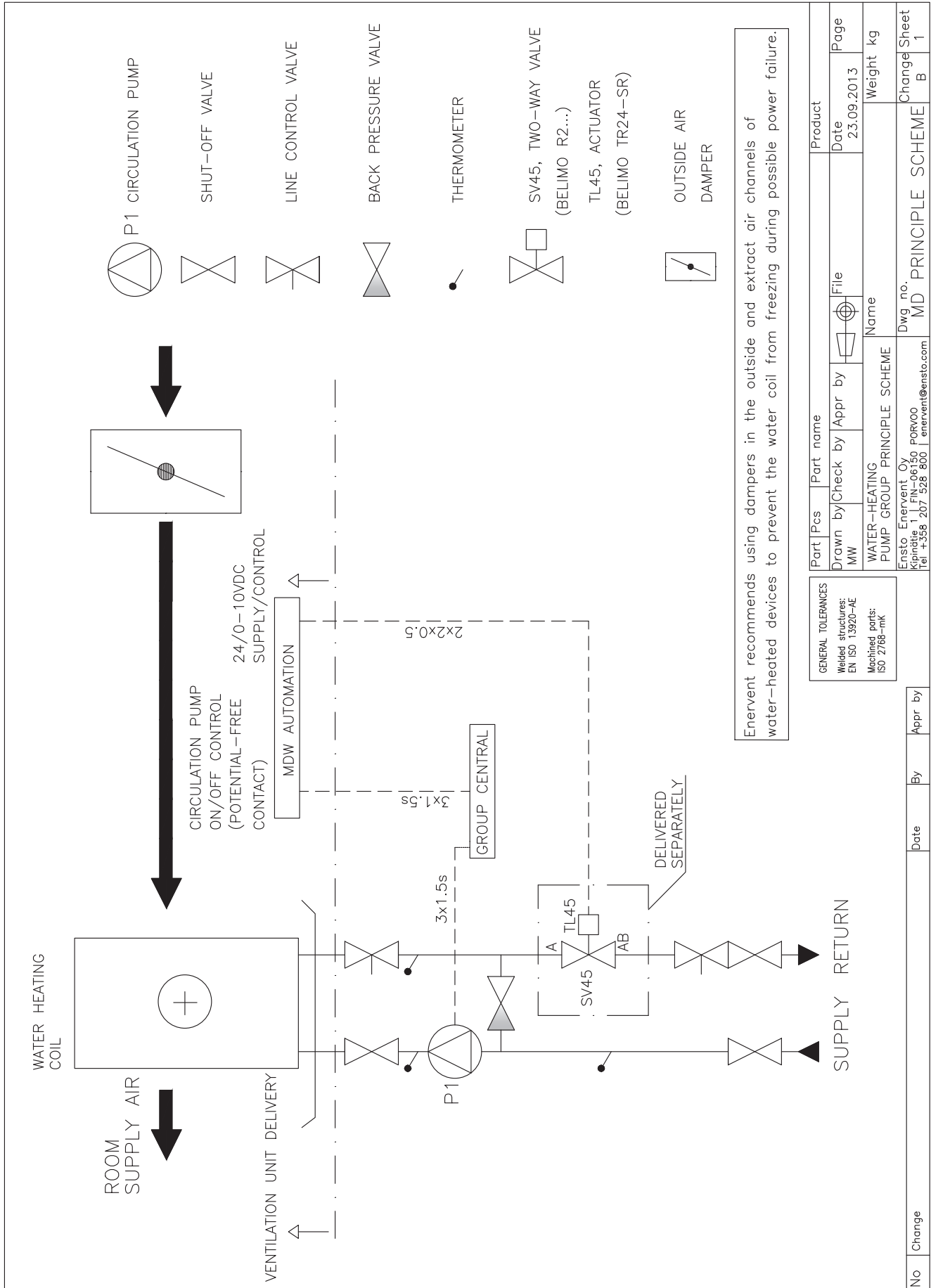

MD CG principle scheme 1

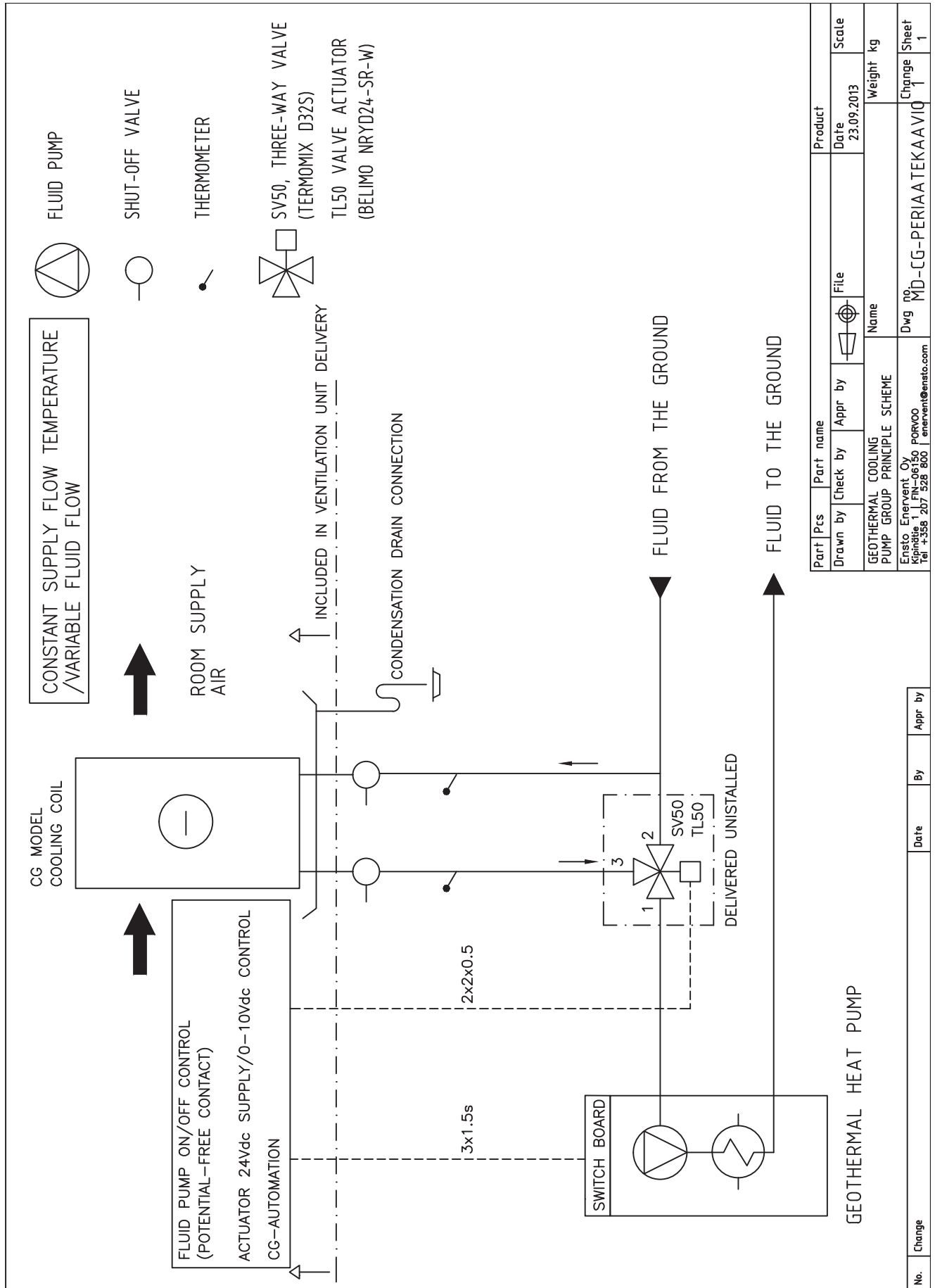

Part	Pts	Part name	Product
Drawn by	Check by	Appr by	Date
			23.09.2013
GEO THERMAL COOLING PUMP GROUP PRINCIPLE SCHEME			Scale
Name			Weight kg
Ensto - Ervent Oy, Puhokatu 10, PO BOX 51, FIN-00050 HELSINKI, FINLAND			Change Sheet
Tel: +358 207 528 800 ervent@ensto.com			1
Dwg No. MD-CG-PERIAATEKAAVIO			

No.	Change	Date	By	Appr by

MD CG principle scheme 2

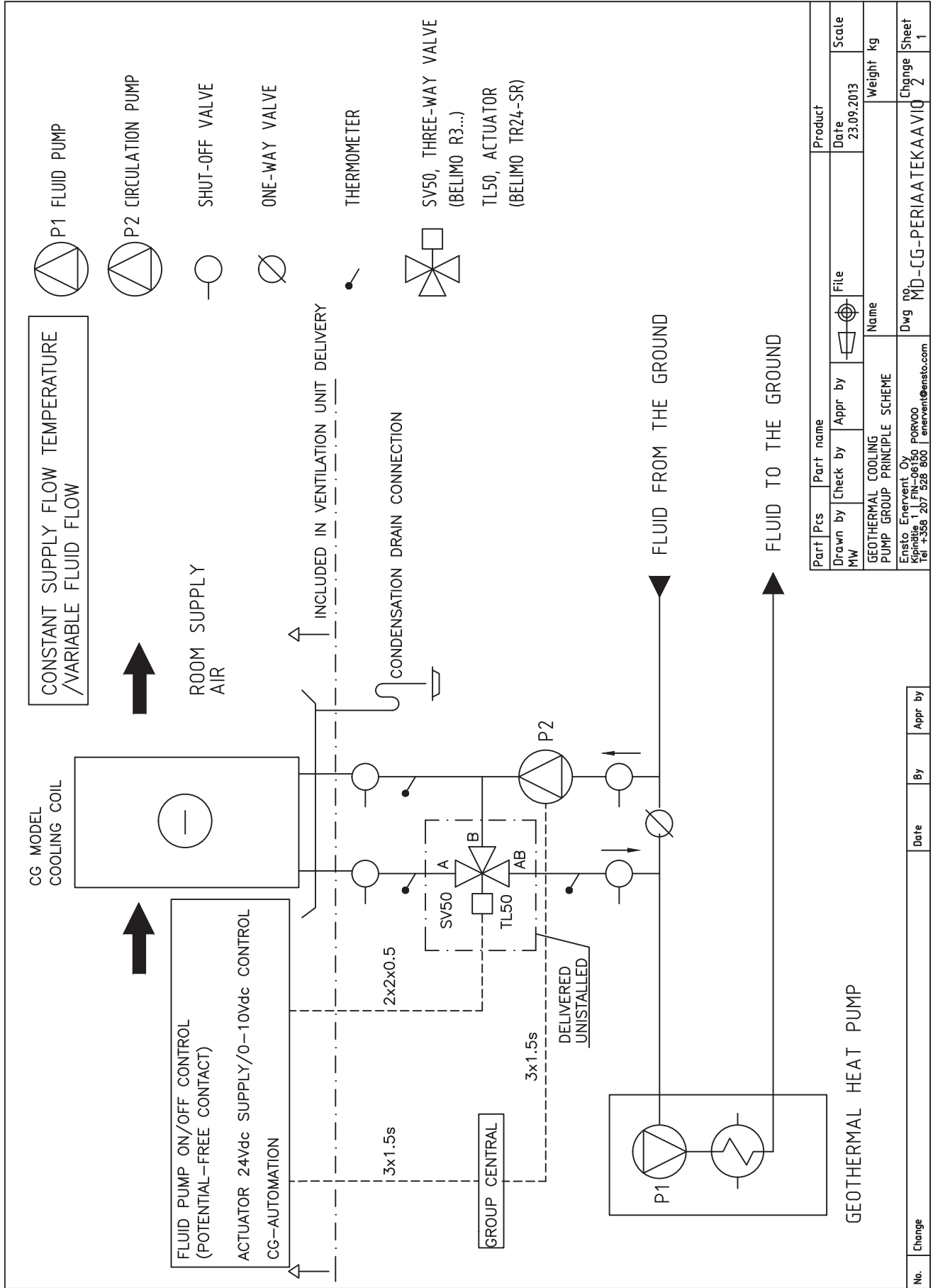

Part	Pcs	Part name	Product
Drawn by	Check by	Appr by	Date
MW			23.09.2013
GEOHERMAL COOLING PUMP GROUP PRINCIPLE SCHEME			Scale
Name			Weight kg
Ensto Enervent Oy			Change
Kipinietie 1, FIN-06150 PORVOO			Sheet
Tel. +358 207 528 800 enervent@ensto.com			1
Dwg no MD-CG-PERIAATEKAAVIO			2

No.	Change	Date	By	Appr by

MD CG principle scheme 4

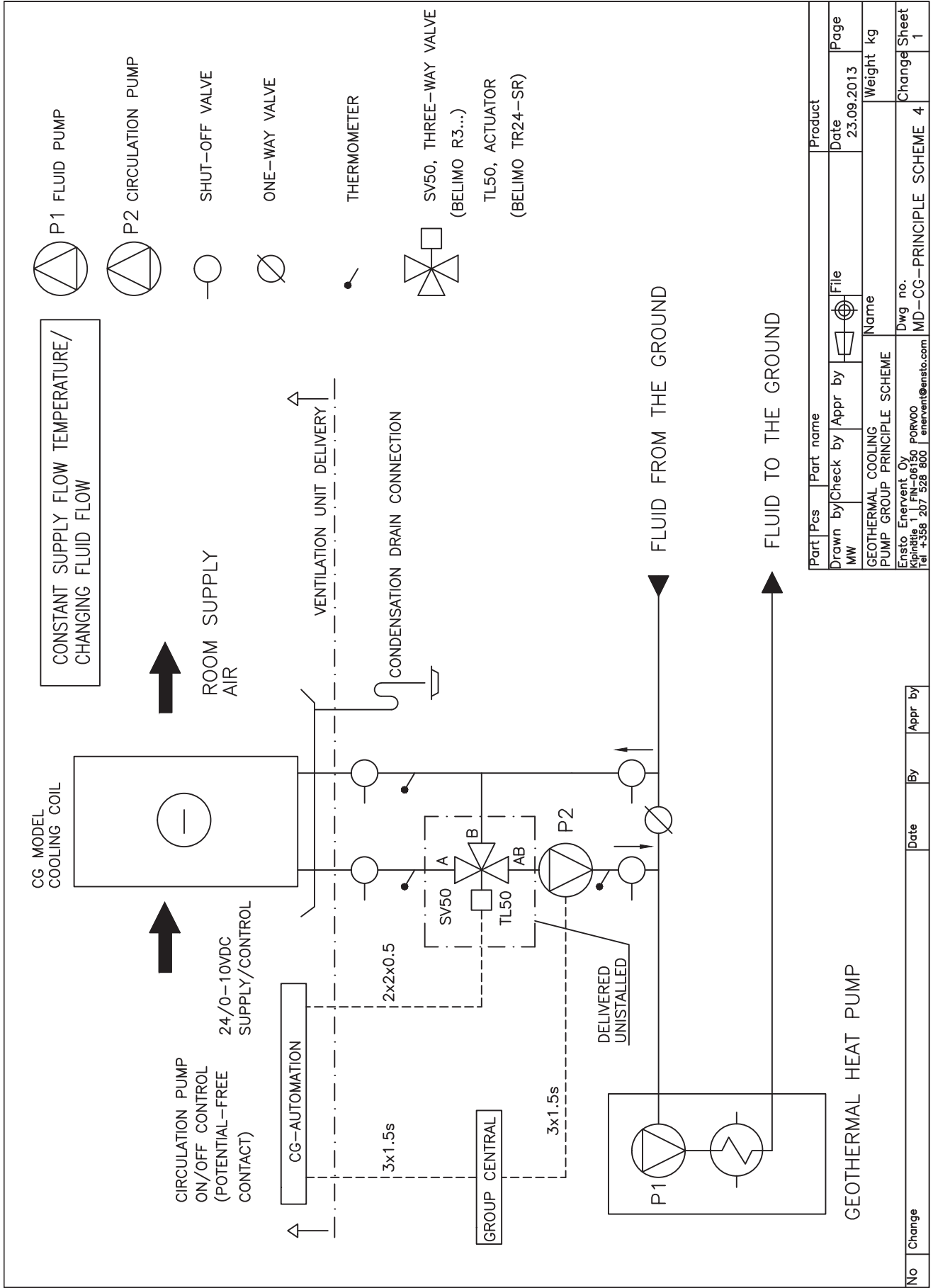

Part	Pcs	Part name	Product
Drawn by	Check by	Appr by	File
MW			
GEOHERMAL COOLING PUMP GROUP PRINCIPLE SCHEME			Date
Name			23.09.2013
Ensto Enervent Oy			Weight kg
Kipinttie 1, FIN-06150 PORVOO			Change Sheet
Tel. +358 207 528 800 enervent@ensto.com			4
Dwg no. MD-CG-PRINCIPLE SCHEME			1

No	Change	By	Date	Appr by

MD CG principle scheme 5

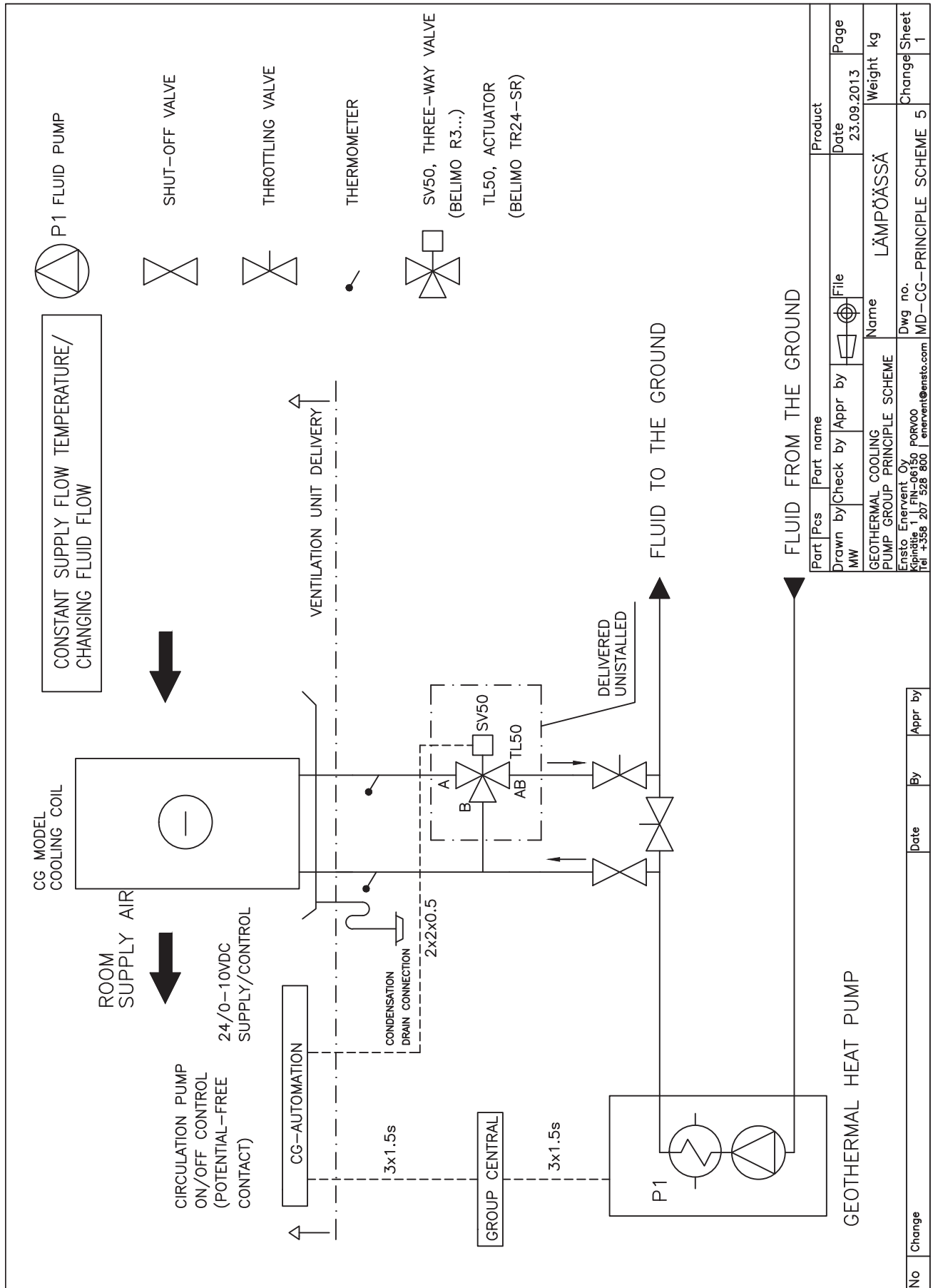

MD CHG principle scheme ground loop

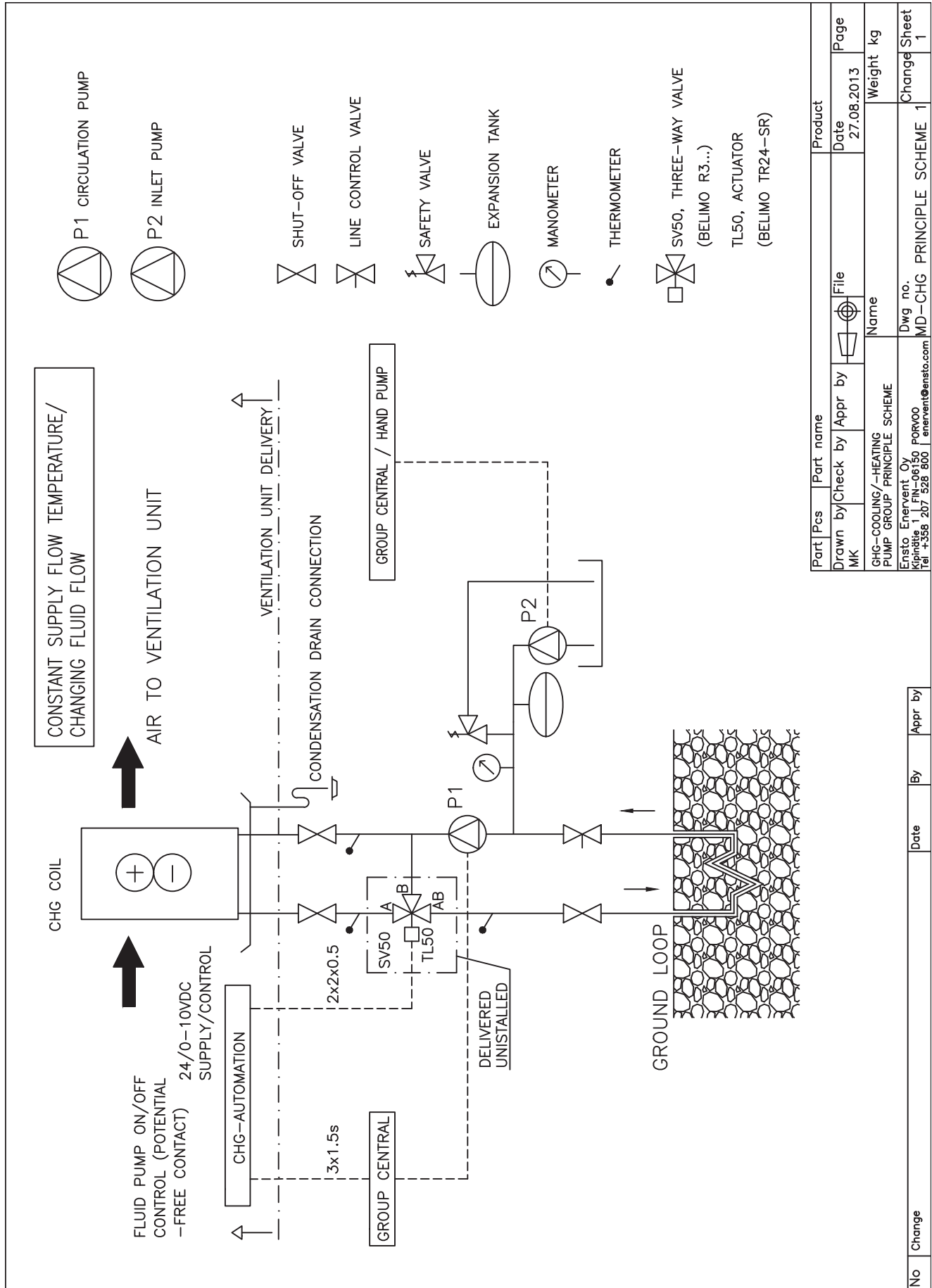

Part	Pcs	Part name	Product
Drawn by	Check by	Appr by	File
MK			
GHG-COOLING/-HEATING PUMP GROUP PRINCIPLE SCHEME		Name	Weight kg
Ernst Energy Oy		Dwg no.	Change
Ernst Energy Oy		MD-CHG PRINCIPLE SCHEME 1	Sheet
Tel: +358 207 528 800 ernst@ernst.com			1

No	Change	Date	By	Appr by

MD CHG principle scheme heat exchanger

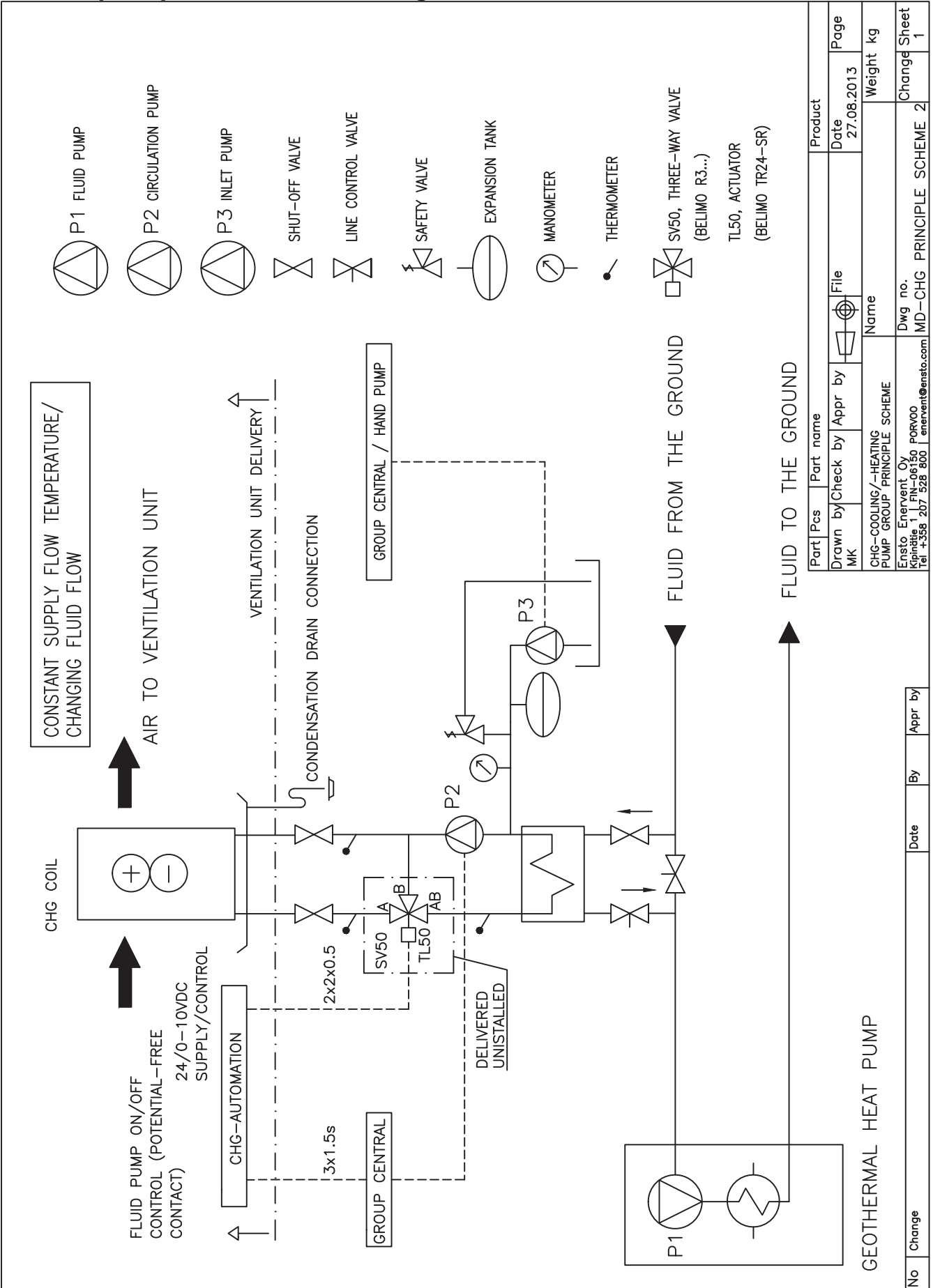

No	Change	Date	By	Appr by

Part	Pcs	Part name	Product
Drawn by	Check by	Appr by	Date
MK			27.08.2013
File		Page	
Name		Weight kg	
Name		Change Sheet	
Dwg no.		1	
Ersto Enervent Oy		MD-CHG PRINCIPLE SCHEME 2	
Kipinkitie 1 FIN-06150 PORVOO			
Tel. +358 207 528 800 enervent@enstersto.com			

MD CW principle scheme

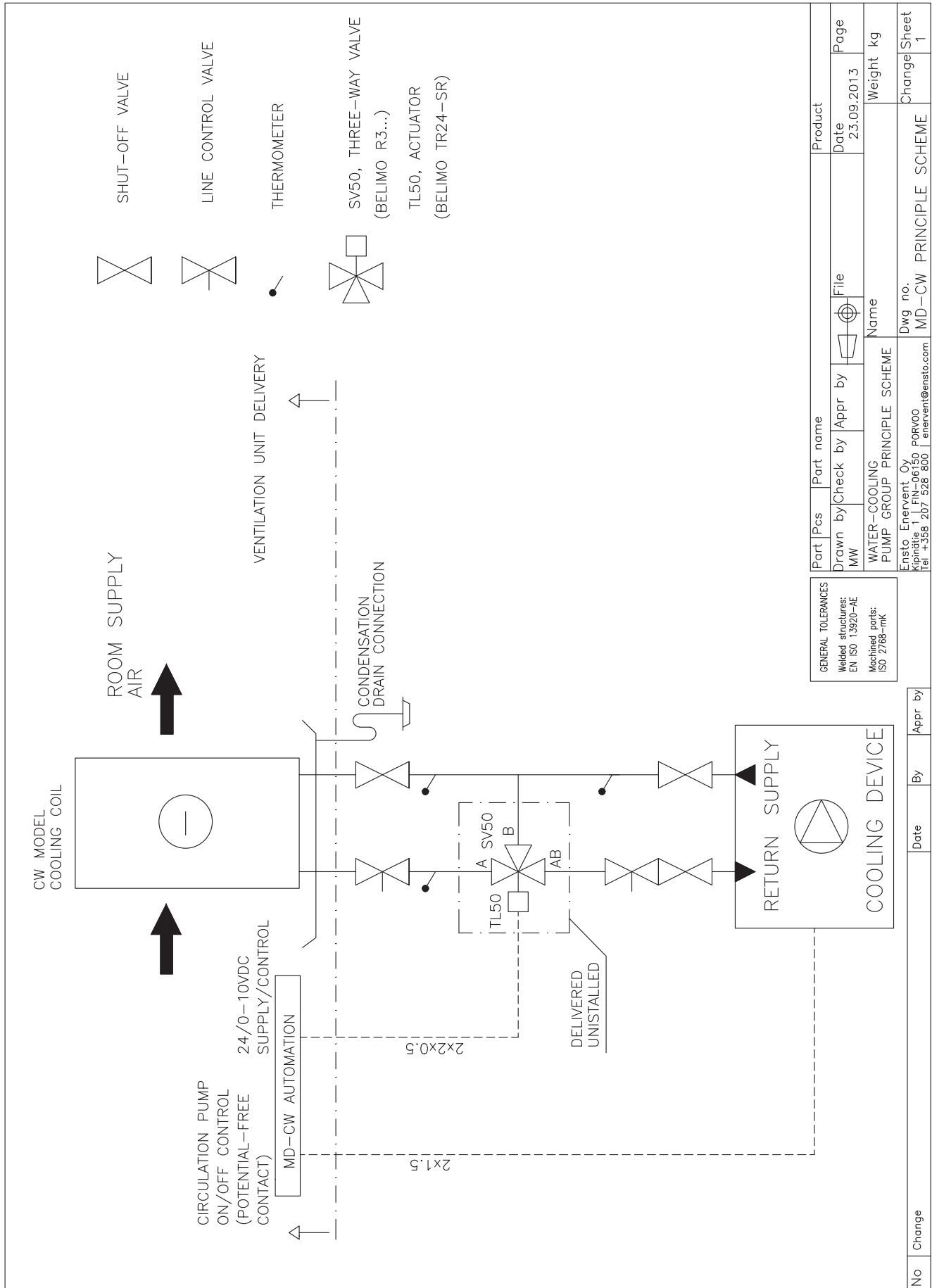

GENERAL TOLERANCES
 Welded structures:
 EN ISO 13920-AE
 Machined parts:
 ISO 2768-mK

Part	Pcs	Part name	Product
Drawn by	Check by	Appr by	Date
MW			23.09.2013
WATER-COOLING PUMP GROUP PRINCIPLE SCHEME			Page
Name			Weight kg
Ensto Energyvent Oy Kopinkatu 1, P.O. Box 150 Tel. +358 207 528 800 energyvent@ensto.com			Change Sheet
Dwg no. MD-CW PRINCIPLE SCHEME			1

Pallas MD TCG principle scheme

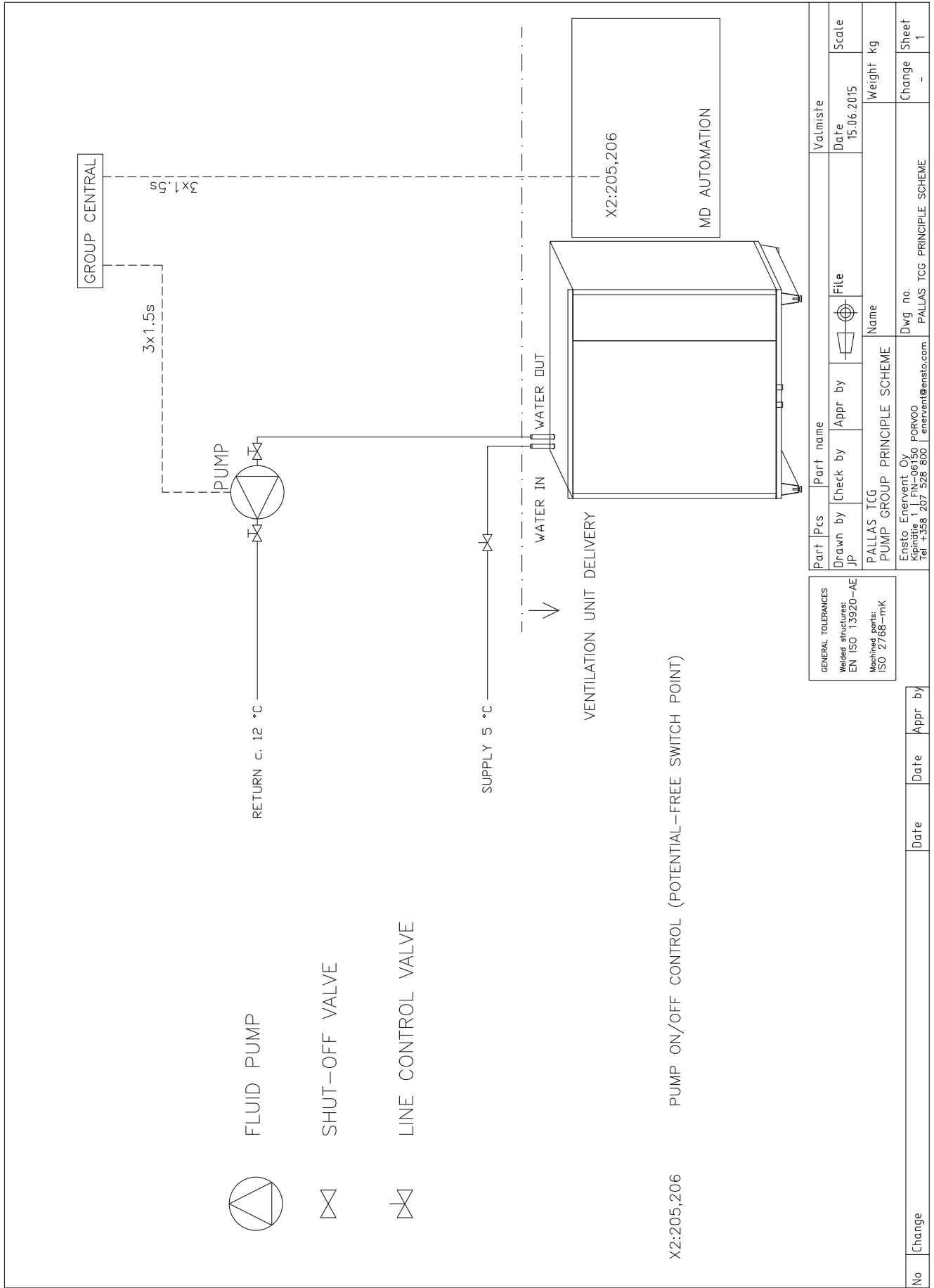

Pandion MD TCG principle scheme 2

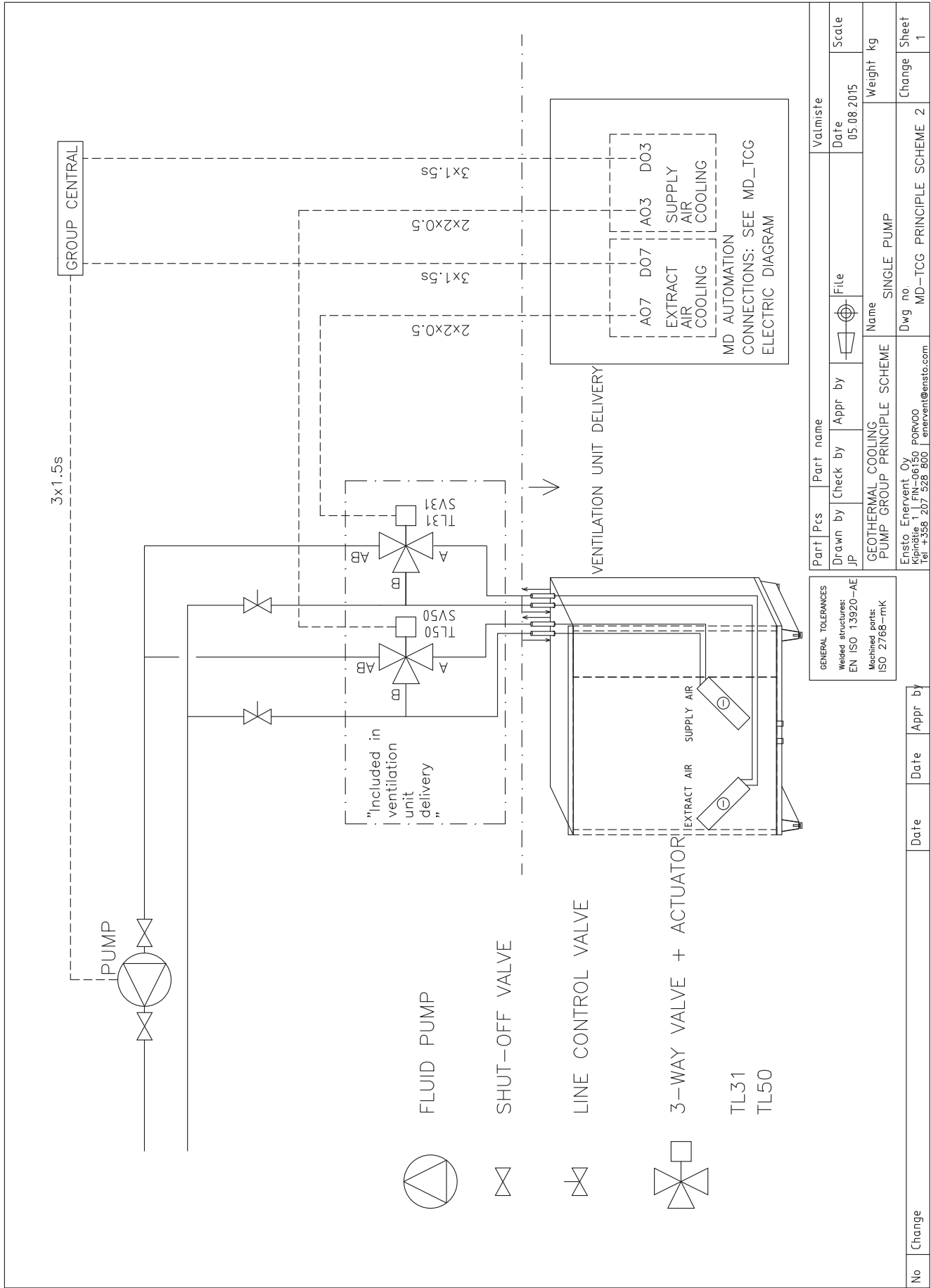

CONTROL DIAGRAMS

EN

ANTURIT / GIVARE / SENSORS / FÜHLER MD

TE01	= Ulkoilma / Uteluft / Outside air / Frischluft
TE02	= Ulkoilma esilämmittimen jälkeen / Uteluft efter förvärmare / Outside air after preheater / Frischluft nach vorwärmer
TE05	= LTO jälkeinen tuloilma / Tilluft efter VVX / Supply after HRW / Zuluft nach WRG
TE07 (Dehum)	= Tuloilma kuivatuksen jälkeen / Tilluft efter avfuktning / Supply after dehumidification / Zuluft nach entfeuchtung
TE10	= Tuloilma / Tilluft / Supply air / Zuluft
TE20	= Huonelämpötila / Rumstemperatur / Room temperature / Raumtemperatur
TE30	= Poistoilma / Frånluft / Extract air / Abluft
TE31 (HP)	= Poistoilmapatterin jälkeinen / Efter frånluftbatteri / Exhaust air after coil / WRG fortluft
TE32	= Jäteilma / Avluft / Waste air / Fortluft
TE45 (MDW)	= Paluuvesi / Returvatten / Return water / Rücklauf
TE46 (CGW)	= CG jäätymisvaara / CG frysskydd / CG freeze protection / CG frostschutz
TE50 (HP)	= Esilämmitetty poistoilma / Förmärmd avluft / Preheated extract air / Forgewärmt abluf
TE51 (HP Oceanic)	= Poistoilma LTO:n jälkeen / Avluft efter VVX / Extract air after HRW / Abluft nach WRG
TE62 (MDX)	= Kylmäaine lämpötila / Kylmedel temperatur / Refrigerant temperature / Kältemittel temperatur
TE80 (Aqua)	= Varaajan lämpötila / Värmeackumulator temperatur / Heat accumulator temperature / Wärmespeicher temperatur
RH10 (Dehum)	= Tuloilma %RH / Tilluft %RH / Supply air %RH / Zuluft %RH
%RH30	= Poisto %RH / Frånluft %RH / Extract air %RH / Abluft %RH
%RH07 (Dehum)	= Tulo %RH kuivatuksen jälkeen / Tilluft %RH efter avfuktning / Supply %RH after dehumidification / Zuluft %RH nach entfeuchtung
PDE10	= Tulo paine-ero / Tilluft tryck differens / Supply pressure difference / Zuluft druckdifferenz
PDS10 (MDE >3kW)	= Tulo painevahti / Tilluft tryckvakt / Supply pressure switch / Zuluft druckschalter
PDE30	= Poisto paine-ero / Frånluft tryck differens / Extract pressure difference / Abluft druckdifferenz

MD ADJUSTMENT CHARTS

MDE-(CG)

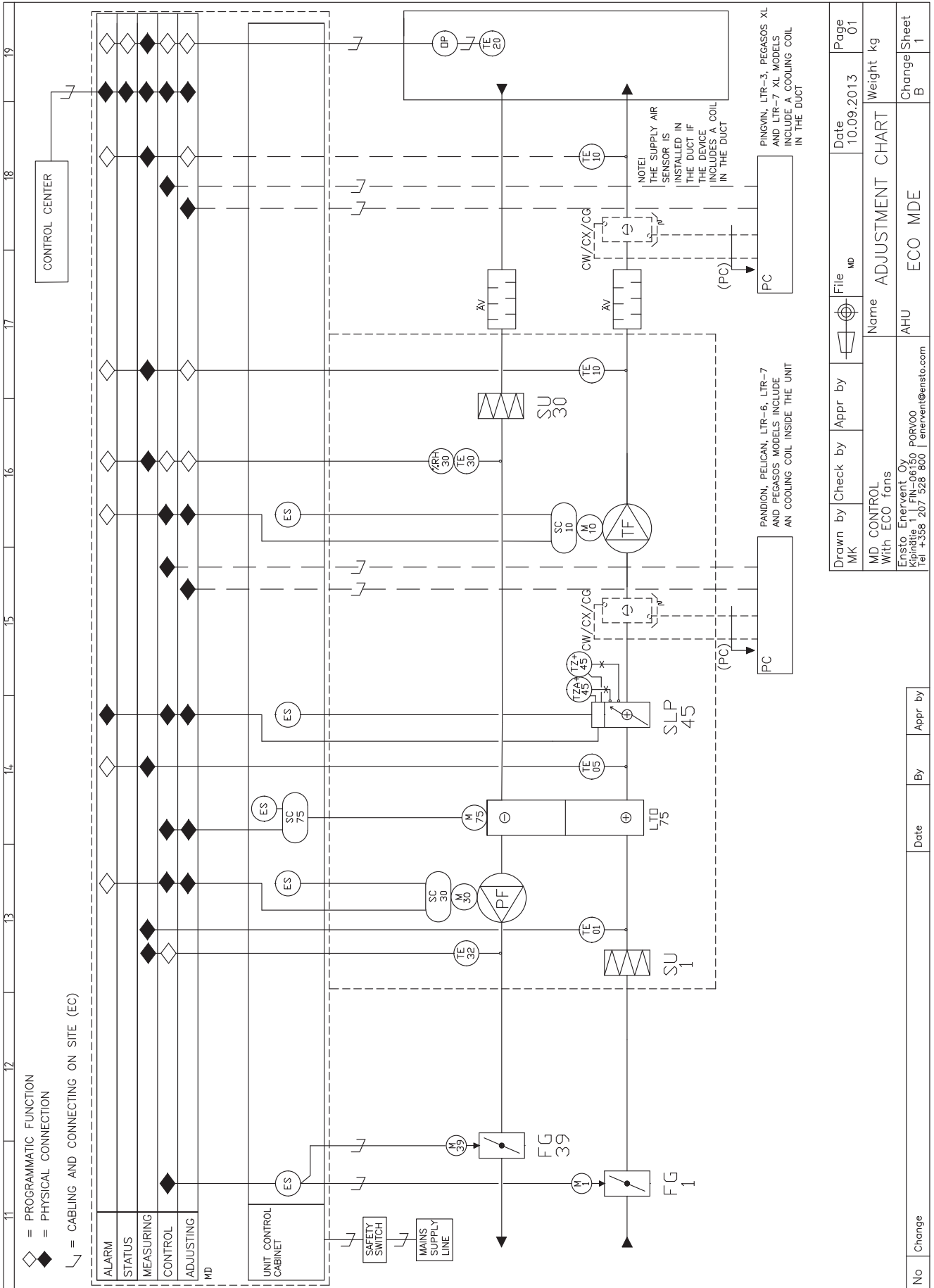

Drawn by	Check by	Appr by	File	Date	Page
MK			md	10.09.2013	01
MD CONTROL With ECO fans			Name	ADJUSTMENT CHART	
Ensto: Ervervent Oy, Pori 00000, Finland Kipinietie 207, 525 600 ervent@ensto.com			AHU	ECO MDE	Change Sheet
No	Change	By	Date	Appr by	Weight kg
					B 1

MDW-(CG)(CHG)

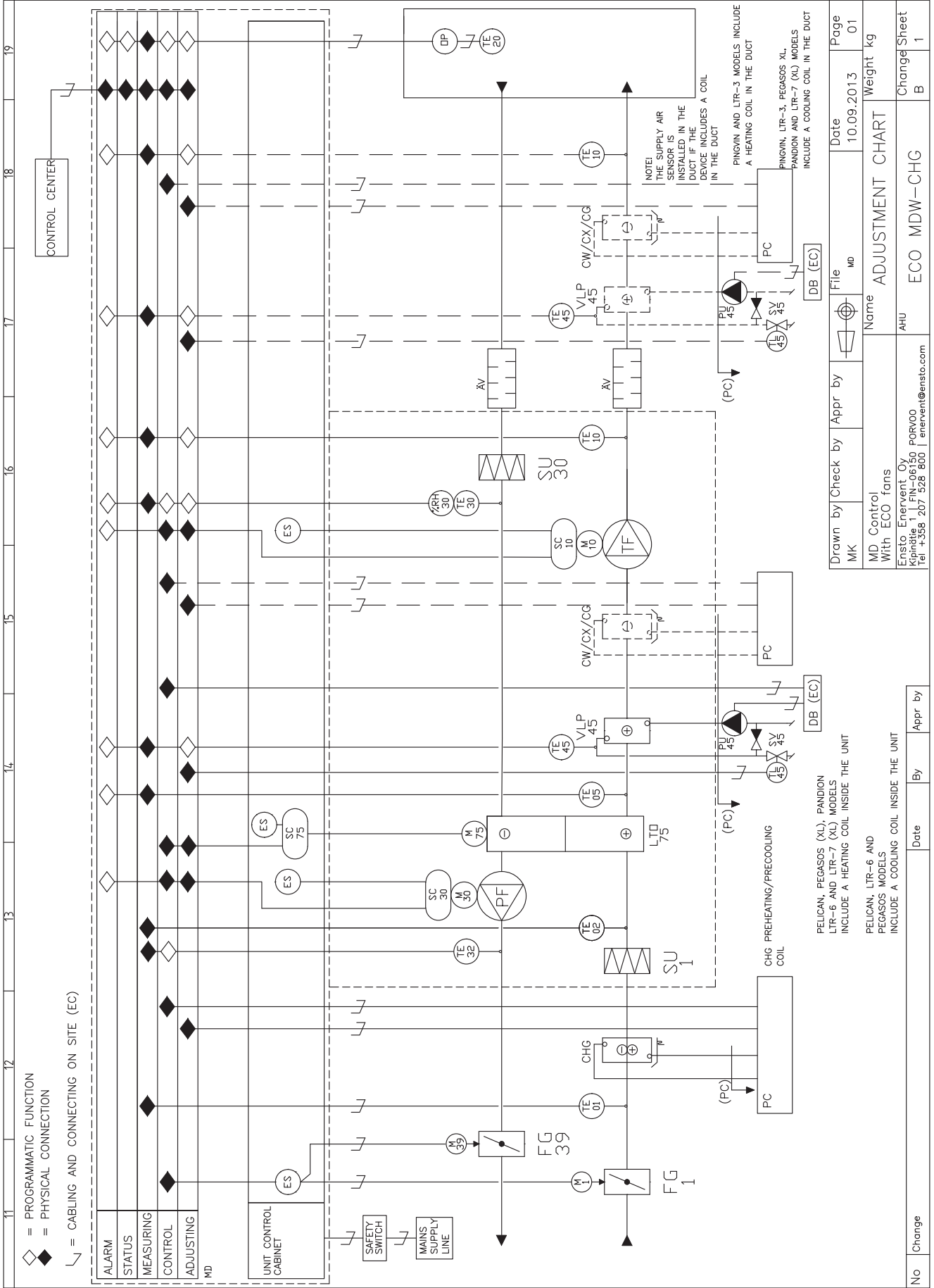

Drawn by	Check by	Appr by	Date	Page
MK	MD	md	10.09.2013	01
Name			Weight	kg
MD Control With ECO fans			B	1
Ensto Enervent Oy, Pöyröväkyläntie 1, FIN-06150 Kiparski, Tel: +358 207 528 800 enervent@ensto.com			Change Sheet	
AHU			ECO MDW-CHG	

No	Change	Date	By	Appr by
PELICAN, PEGASOS (XL), PANDION LTR-6 AND LTR-7 (XL) MODELS INCLUDE A HEATING COIL INSIDE THE UNIT				
PELICAN, LTR-6 AND PEGASOS MODELS INCLUDE A COOLING COIL INSIDE THE UNIT				

MD MDCG-W

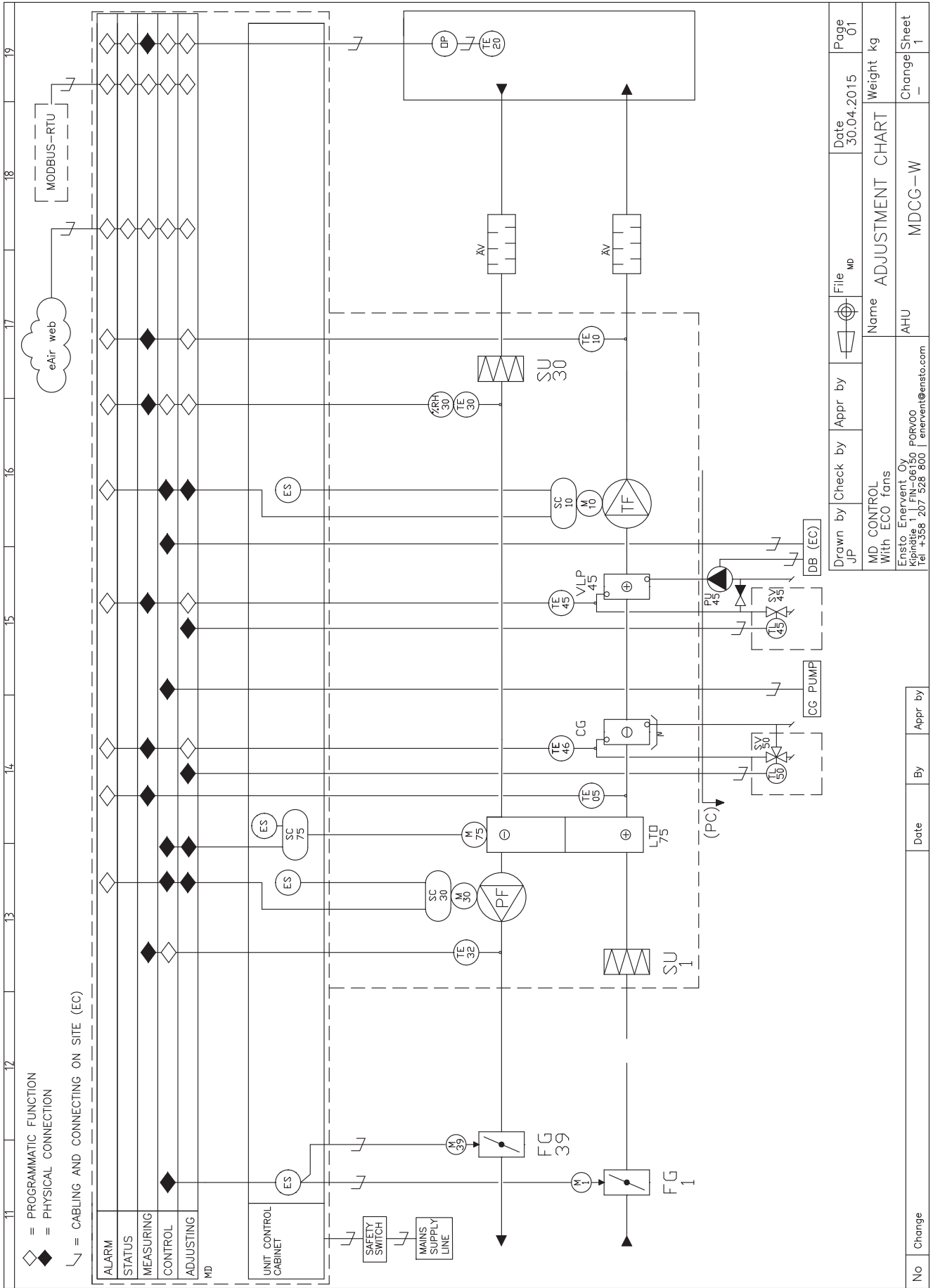

Drawn by	Check by	Appr by	File	Date	Page
JP			MD	30.04.2015	01
Name			ADJUSTMENT CHART		
Name			AHU		
Ensto, Enervent Oy Pöytäkatu 10 00100 Helsinki Tel: +358 207 528 800 enervent@ensto.com			MDCG-W		
No	Change	Date	By	Appr by	Weight kg
					Change Sheet
					1

PALLAS ADJUSTMENT CHARTS

Pallas switch board

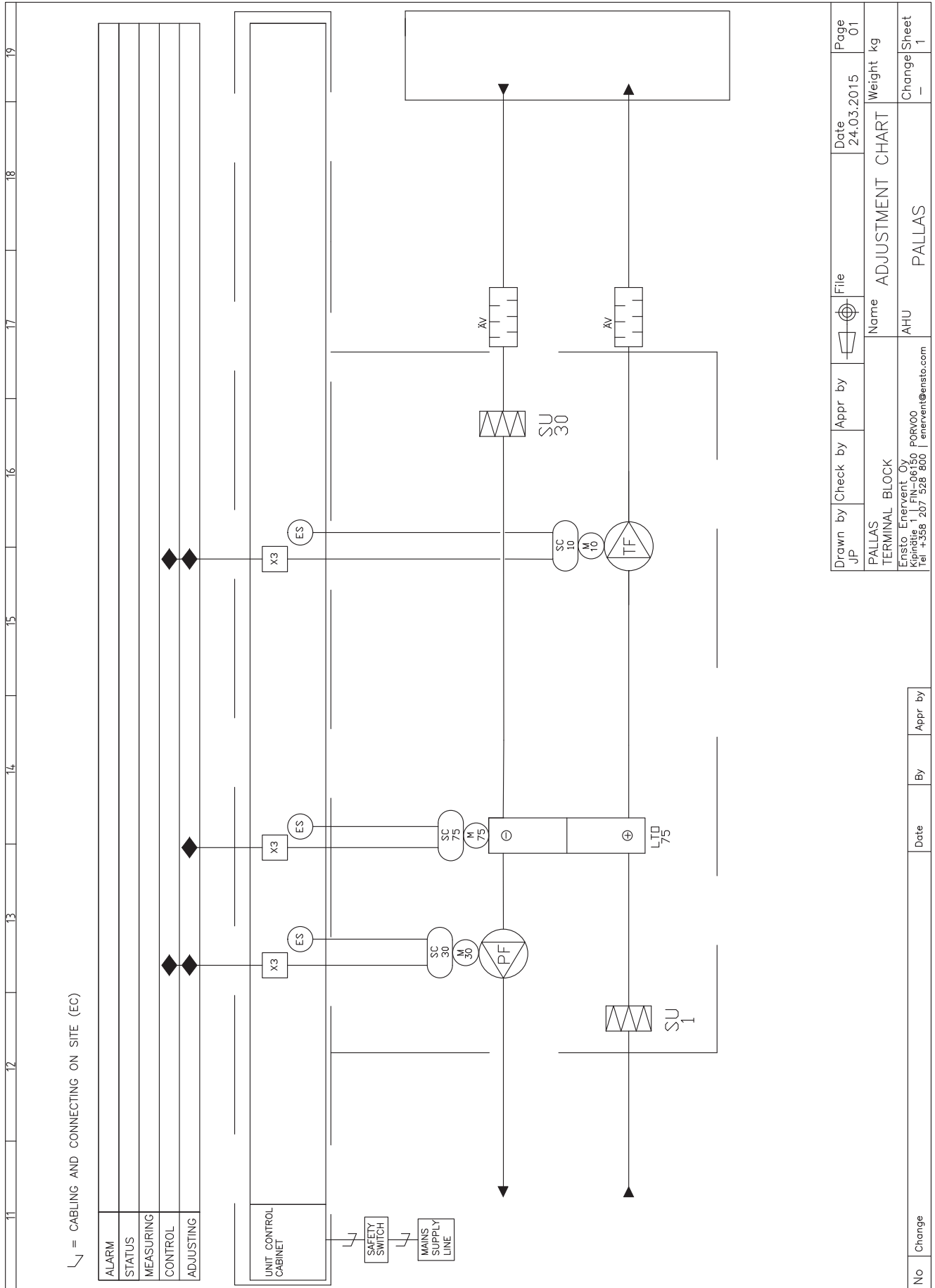

Drawn by JP	Check by	Appr by	File	Date 24.03.2015	Page 01
PALLAS TERMINAL BLOCK			Name ADJUSTMENT CHART	Weight kg	Change Sheet
Eristo Enervent Oy Kivinkuja 1, FIN-06150 PORVOO Tel. +358 207 528 800 enervent@eristo.com			AHU	PALLAS	1

No	Change	Date	By	Appr by

MD Pallas MDE-CG

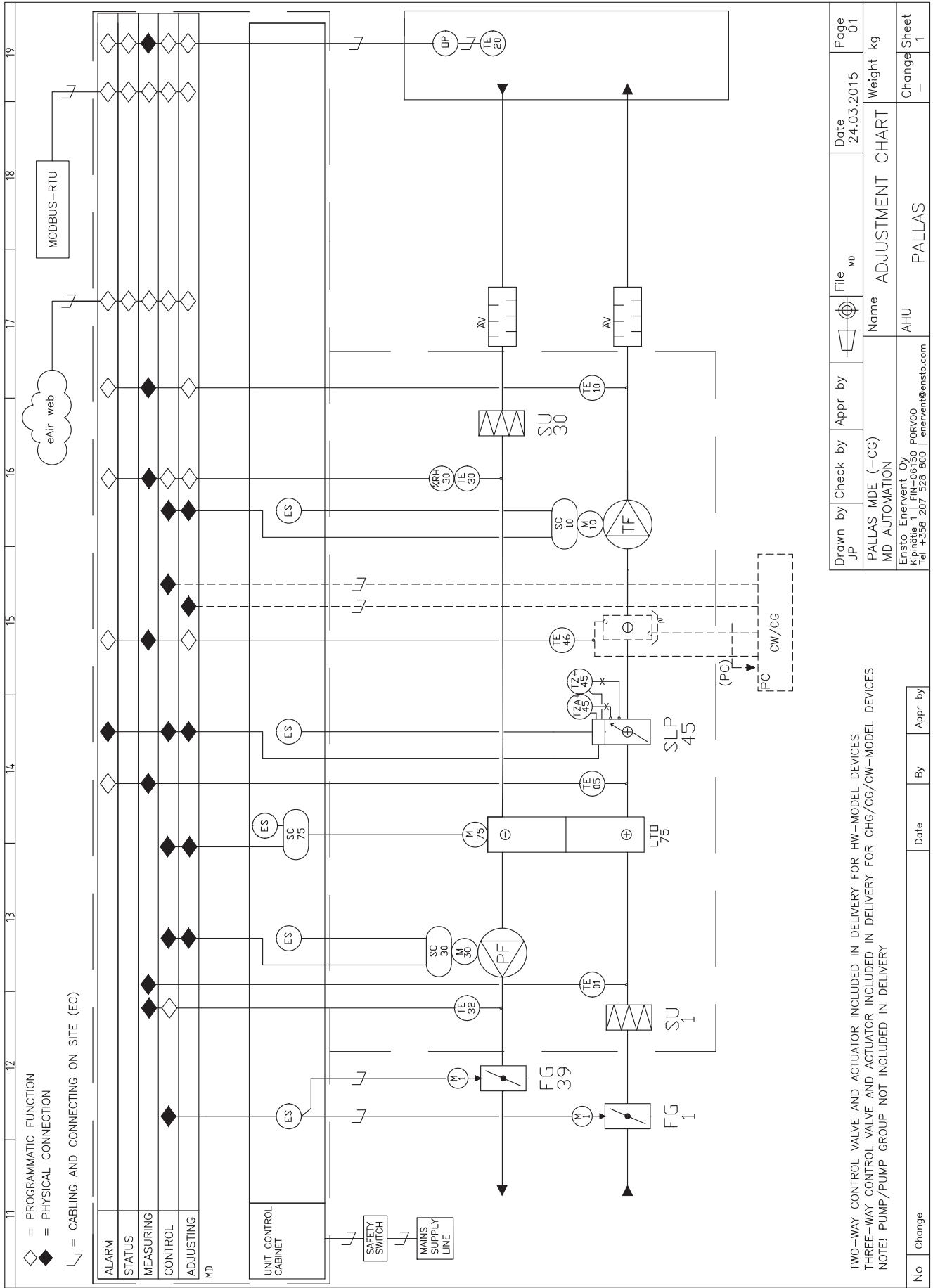

Drawn by	Check by	Appr by	File	Date	Page
JP	PALLAS MDE (-CG)		MD	24.03.2015	01
MD AUTOMATION	Name	Weight	Change	Sheet	
Ensto Enervent Oy Kipinätie 1 FIN-06150 PORVOO tel. +358 207 528 800 enervent@ensto.com	AHU	kg	—	1	

TWO-WAY CONTROL VALVE AND ACTUATOR INCLUDED IN DELIVERY FOR HW-MODEL DEVICES					
THREE-WAY CONTROL VALVE AND ACTUATOR INCLUDED IN DELIVERY FOR CHG/CG/CW-MODEL DEVICES					
NOTE! PUMP/PUMP GROUP NOT INCLUDED IN DELIVERY					
No	Change	Date	By	Appr by	

MD Pallas MDW-CG

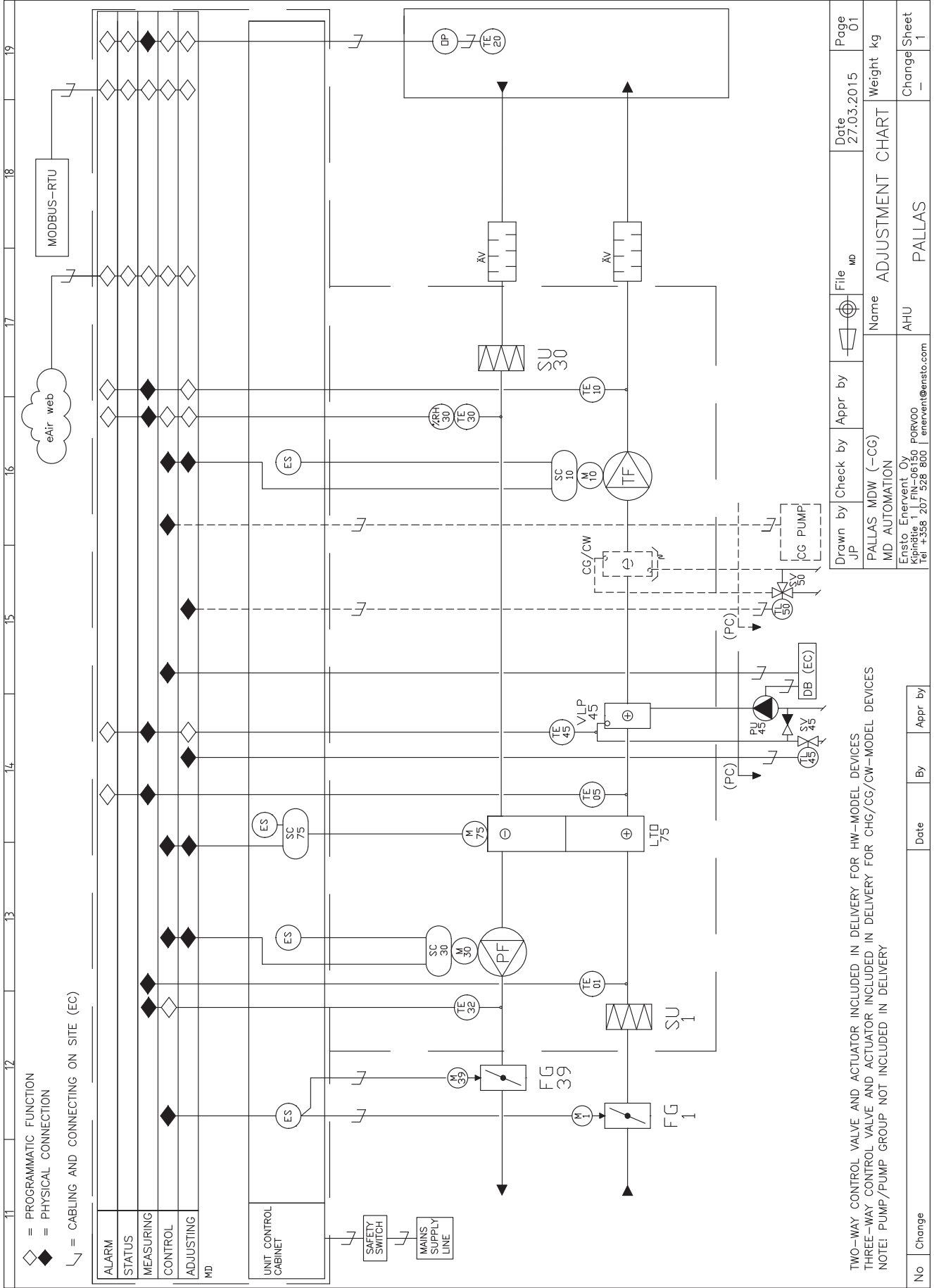

MD Pallas MDCG-E

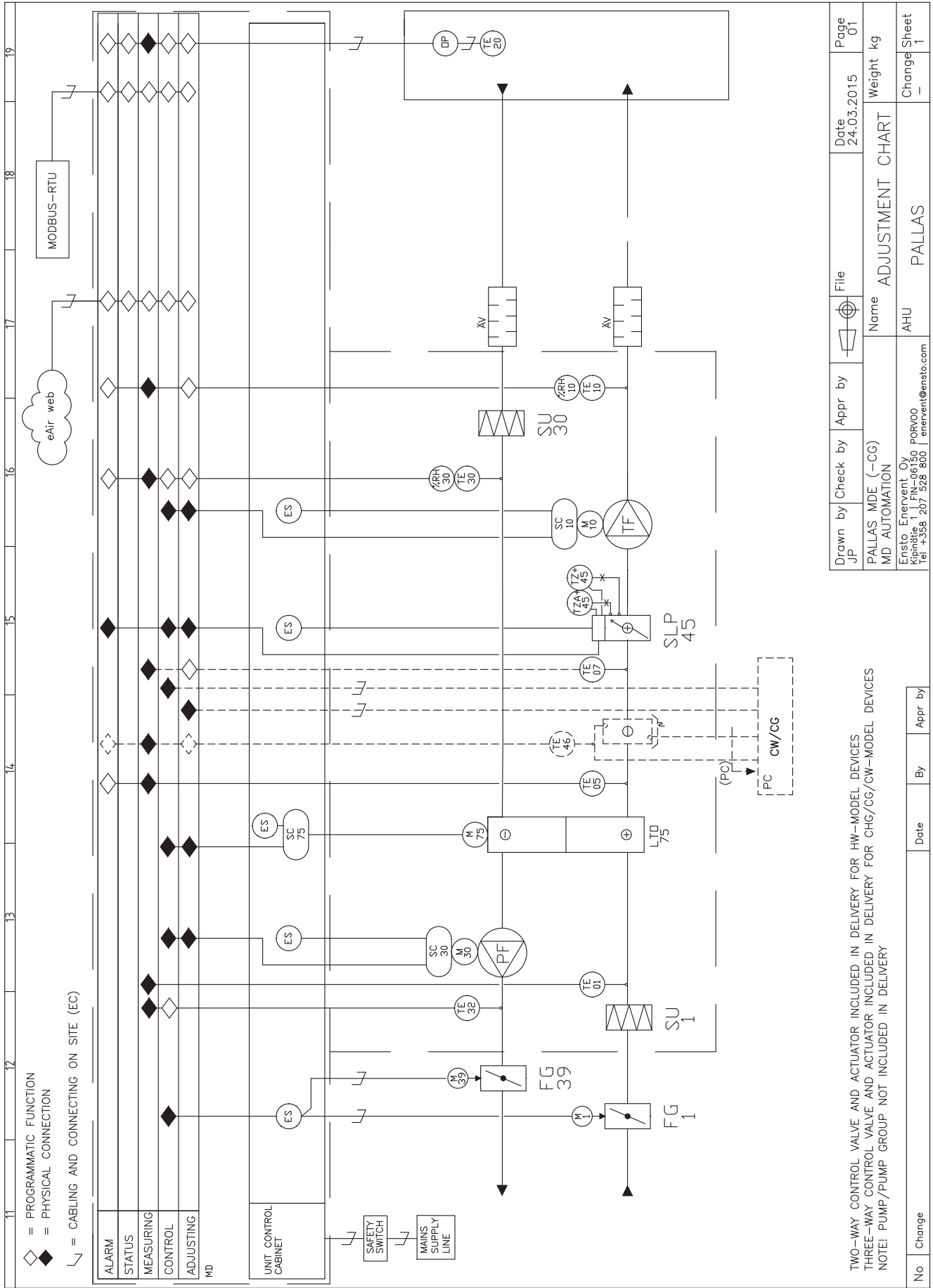

Drawn by	JP	Check by	PALLAS MDE (-CG)	Appr by	MD AUTOMATION	File	ADJUSTMENT CHART	Date	24.03.2015	Page	01
							Name	PALLAS	Weight	kg	Change Sheet
							Ensto Enervent Oy	Ensto			1
							Kipinätie 1 FIN-06150 PORVOO	AHU			
							tel +358 207 528 600 enervent@ensto.com				

TWO-WAY CONTROL VALVE AND ACTUATOR INCLUDED IN DELIVERY FOR HW-MODEL DEVICES
 THREE-WAY CONTROL VALVE AND ACTUATOR INCLUDED IN DELIVERY FOR CHG/CG/CW-MODEL DEVICES
 NOTE! PUMP/PUMP GROUP NOT INCLUDED IN DELIVERY

No	Change	By	Date	Appr by

MD Pallas MDCG-W

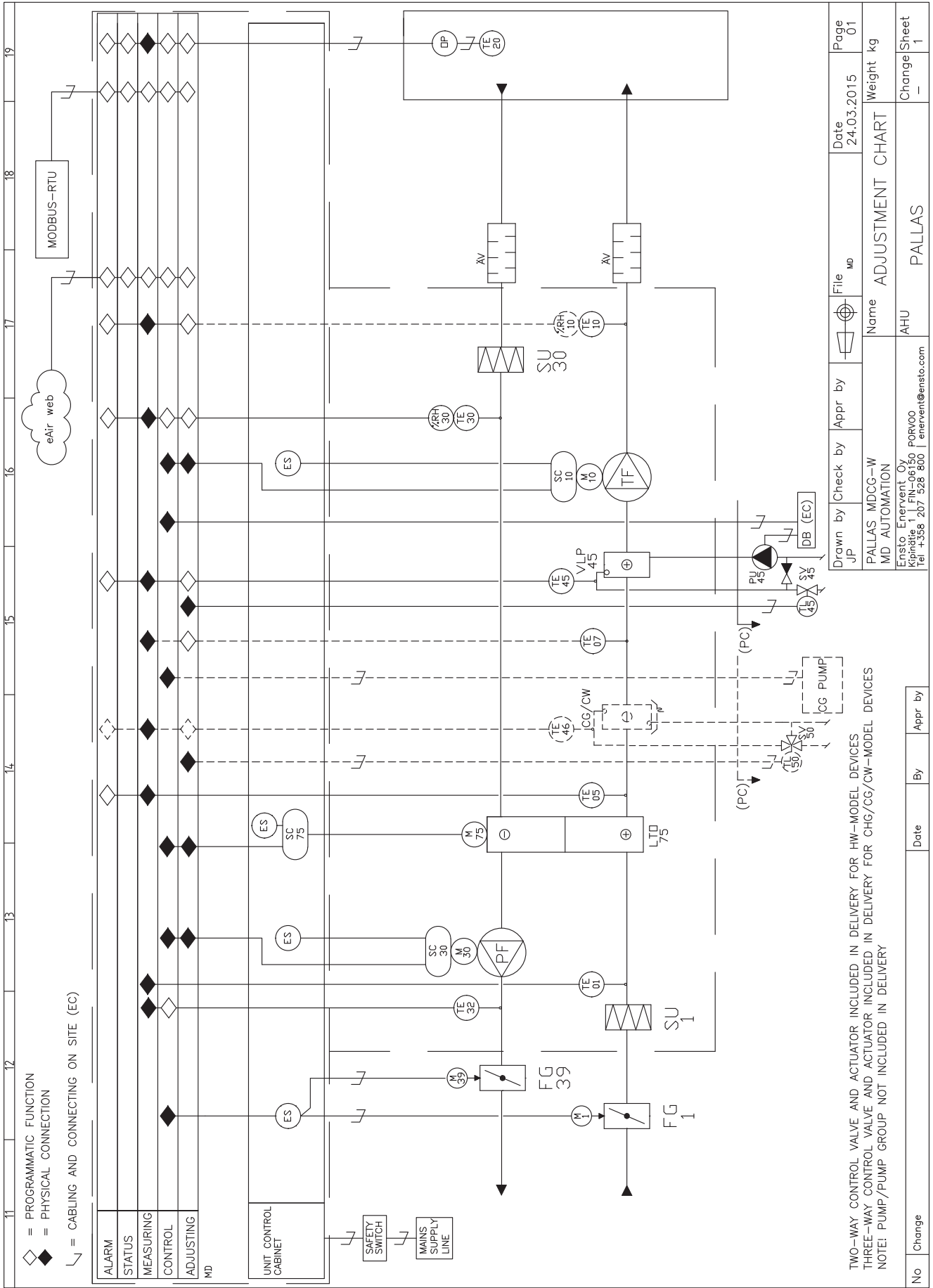

TWO-WAY CONTROL VALVE AND ACTUATOR INCLUDED IN DELIVERY FOR HW-MODEL DEVICES
 THREE-WAY CONTROL VALVE AND ACTUATOR INCLUDED IN DELIVERY FOR CHG/CG/CW-MODEL DEVICES
 NOTE: PUMP/PUMP GROUP NOT INCLUDED IN DELIVERY

Drawn by	JP	Check by	JP	Appr by	JP	File	mb	Date	24.03.2015	Page	01
Name								ADJUSTMENT CHART		Weight	kg
PALLAS MDCG-W MD AUTOMATION								AHU		PALLAS	
Ensto Energyvent Oy Kirkko 11, FIN-06150 PORVOO Tel: +358 207 528 800 energyvent@ensto.com								Change		Sheet	
No								Change		Sheet	

TWIN TROPIC ADJUSTMENT CHART

MD TwinTropic CW (E)

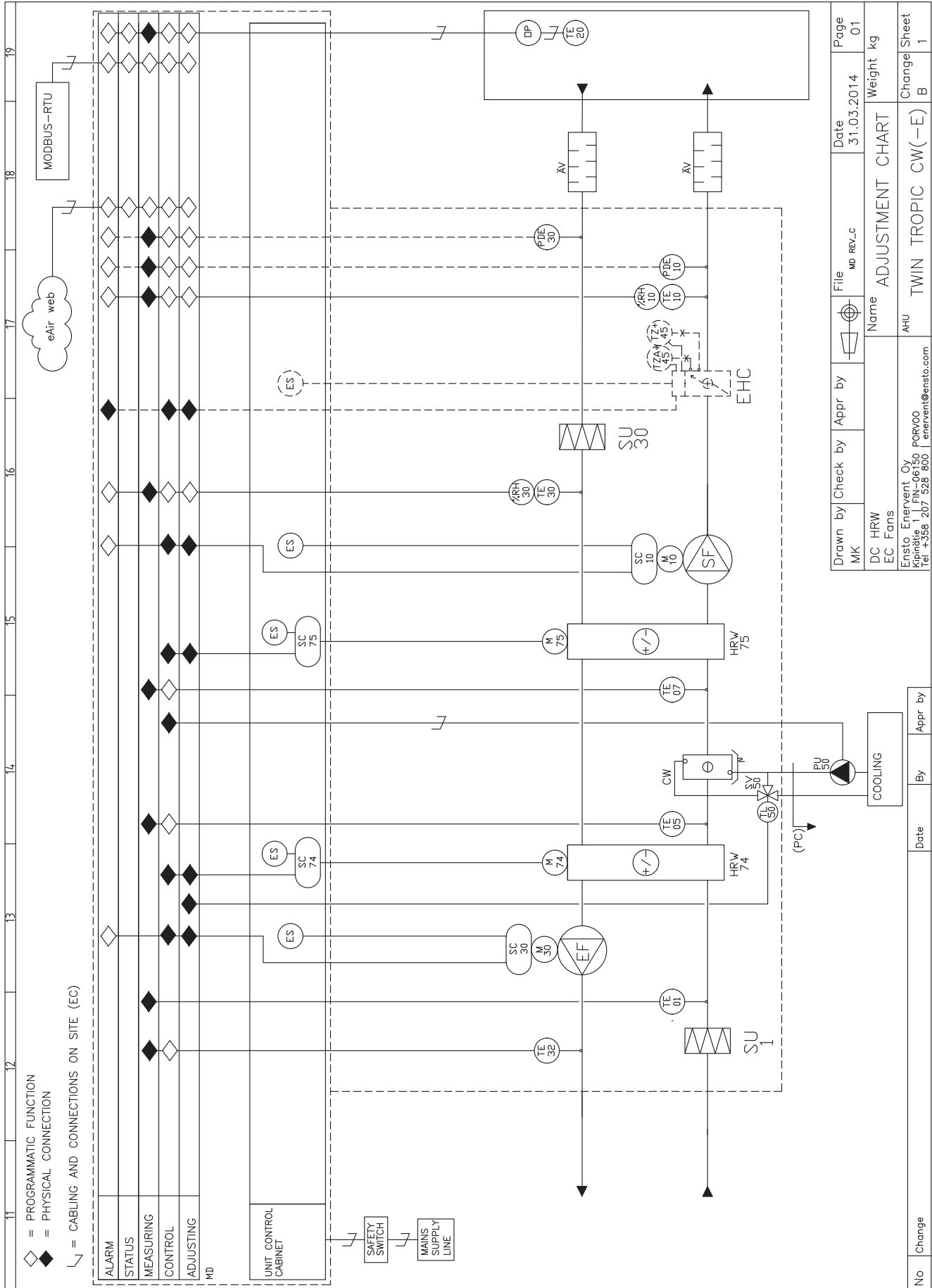

Drawn by	Check by	Appr by	File	Date	Page
MK	MK		MD REV_C	31.03.2014	01
DC HRW	EC Fans		Name	ADJUSTMENT CHART	
Ensto, Enervent Oy, Porvoo Kipinkatu 6, FIN-01500 Puhelin: +358 207 528 800 email: entrent@ensto.com			AHU	TWIN TROPIC CW(-E)	Change Sheet
			Weight	kg	
			B	1	

No	Change	Date	By	Appr by

Table of parameters

MENU	SUBMENU	FACTORY SETTINGS	FIELD SETTINGS
Setup wizard			
Display settings	Display brightness	97 %	
	Sleep mode delay	90 sec	
	Sleep mode delay for wall mounting bracket	OFF	
	Temperature shown on front of panel	Outside air temperature	
Mode of operations	Use	Home	
	Temperature control	Supply air. Factory setting is extract air, if the unit includes cooling feature.	
	Cooling	OFF	
	Outside temperature limit for cooling	17 °C	
	Heating	ON	
	Outside temperature limit for heating	25 °C	
	Minimum temperature of supply air	13 °C	
	Maximum temperature of supply air	40 °C	
	Heating/Cooling limitation	OFF	
	Heating	18 °C	
	Cooling	24 °C	
	TE20 -sensor	OFF	
	TE21 -sensor	OFF	
	Room temperature sensor 1	OFF	
	Room temperature sensor 2	OFF	
Room temperature sensor 3	OFF		
AI settings	Analog input 1	% RH sensor 1 Low/high voltage 0/10 Low/high voltage effect 0/100	
	Analog input 2	% RH sensor 2 Low/high voltage 0/10 Low/high voltage effect 0/100	
	Analog input 3	None	
	Analog input 4	None	
	Analog input 5	CO2 sensor 1 Low/high voltage 0/10 Low/high voltage effect 0/2000	
	Analog input 6	CO2 sensor 2 Low/high voltage 0/10 Low/high voltage effect 0/2000	
Constant duct pressure settings	Constant duct pressure mode	OFF	
	Airflow setup mode	Constant pressure	
	P-band	25	
	I-time	5 s	
	DZ	2 Pa	
	Alarm delay for supply air duct pressure	200 s	
	Alarm delay for extract air duct pressure	200 s	
	Alarm limit	10 Pa	

MENU	SUBMENU	FACTORY SETTINGS	FIELD SETTINGS
Heat recovery settings	Defrosting	OFF	
	Limit temperature for winter boost	8 °C	
	Arctic mode	OFF	
Mode settings			
Home mode settings	Supply air	30 %	
	Extract air	30 %	
Min. fan speed (only for heatpumps)	Supply air	70 %	
	Extract air	70 %	
Summer night cooling	Summer night cooling	OFF	
	Start temperature	25 C	
	Stop temperature	21 C	
	Lowest outside temperature	10 C	
	Min. temperature difference	1 C	
	Supply fan	70 %	
	Extract fan	70 %	
	Start time	22:00	
	Stop time	7:00	
	Weekdays	every day	
	Active cooling blocked	ON	
Away mode settings	Supply air	20 %	
	Extract air	20 %	
	Temperature setback	2 C	
	Heating	ON	
	Cooling	ON	
Manual boosting settings	Boost duration	30 min	
	Supply air	90 %	
	Extract air	90 %	
Manual overpressure settings	Overpressure duration	10 min	
	Supply air	50 %	
	Extract air	30 %	
Boosting settings			
Humidity boost settings	%RH boosting	OFF	
	Summer/winter limit temperature	4 C	
	%RH boost limit value	45 %	
	Threshold value 48 h %RH	15 %	
	Max. supply air fan speed	90 %	
	Max. extract air fan speed	90 %	
	Rotor dehumidification	OFF	
CO ₂ boost settings	CO ₂ boost	OFF	
	CO ₂ boost limit value	1000 ppm	
	Max. supply air fan speed	90 %	
	Max. extract air fan speed	90 %	

MENU	SUBMENU	FACTORY SETTINGS	FIELD SETTINGS
Temperature boost settings	Temperature boost	OFF	
	Select temperature measurement	Extract air temperature	
	Max. supply air fan speed	90 %	
	Max. extract air fan speed	90 %	
Cooker hood / CVC	Cooker hood on, Supply air	50 %	
	Cooker hood on, Extract air	30 %	
	Central vacuum cleaner on, Supply air	50 %	
	Central vacuum cleaner on, Extract air	30 %	
	Cooker hood and CVC on, Supply air	70 %	
	Cooker hood and CVC on, Extract air	30 %	
	Cooker hood, CVC and overpressure on, Supply air	100 %	
	Cooker hood, CVC and overpressure on, Extract air	30 %	
Modbus and eAir web settings			
Modbus settings	Modbus id	1	
	Modbus speed	19200	
	Modbus parity	None	
eAir Web settings	Serial number		
	Pin code		
eAir Web Settings -> Network settings	DHCP	ON	
Network settings when DHCP OFF	IP address		
	Gateway		
	Subnet mask		
	DNS		

EU DECLARATION OF CONFORMITY

We declare that our products follows the provisions of low voltage directive LVD 2006/95/EC, electromagnetic compatibility directive EMC 2004/108/EC, machine directive MD 2006/42/EC, radio equipment and telecommunications terminal equipment directive R&TTE 1999/5/EC, ROHS II directive 2011/65/EU and battery directive 2013/56/EU.

Manufacturer: Ensto Enervent Oy
 Manufacturer's contact: Kipinätie 1, 06150 Porvoo, FINLAND, Tel +358 207 528 800, fax +358 207 528 844
 enervent@enervent.fi, www.enervent.fi

Description of the product: Ventilation unit with heat recovery

Trade name of the product: **Enervent® series:**

Pinion, Pingvin, Pingvin XL, Pingvin Kotilämpö, Pandion, Pandion Twincoil, Pelican, Pelican HP, Pegasos, Pegasos XL, Pegasos HP, Pegasos Twintropic, Pallas, Pallas HP, Liggolo, LTR-2, LTR-3, LTR-4, LTR-6, LTR-7, LTR-7 XL.

The products are in conformity with the following standards:

LVD EN 60335-1:2012/AC:2014
 EN 62233:2008/AC:2008

EMC EN 61000-3-2:2006/A1:2009/A2:2009 ja EN 61000-3-3:2008
 EN 61000-6-1:2007 ja EN 61000-6-3:2007/A1:2011/AC:2012
 EN 55014-1:2006/A2:2011 ja EN 55014-2:1997/A2:2008

R&TTE EN 60950-1:2006

MD EN ISO 12100

ROHS EN 50581:2012

The conformity of each manufactured product is taken care according our quality descriptions.

Product is CE-marked year 2015.

Porvoo 16th of November 2015

Ensto Enervent Oy



Tom Palmgren
 Technology manager

REPRESENTATIVES FOR THE PRODUCTS OUTSIDE FINLAND

- Sweden:** Ensto Sweden Ab, Västberga Allé 5, 126 30 Hägersten, SWEDEN, tel +46 8 556 309 00
- Norway:** Noram Produkter Ab, Gml. Ringeriksvei 125, 1356 BEKKESTUA, NORWAY, tel +47 95 49 67 43
- Estonia:** As Comfort Ae, Jaama 1, 72712 PAIDE, ESTONIA, tel +372 38 49 430
- Ireland:** Entropic Ltd., Unit 3, Block F, Maynooth Business Campus, Maynooth, Co. Kildare, IRELAND, tel +353 64 34920
- Germany:** e4 energietechnik gmbh, Burgunderweg 2, 79232 MARCH, GERMANY, tel +49 7665 947 25 33
- Austria:** M-Tec Mittermayr GmbH, 4122 ARNREIT, AUSTRIA, tel +43 7282 7009-0
- Poland:** Ensto Pol Sp. z o.o., ul.Starogardzka 17A, 83-010 STRASZYN, POLAND, tel +48 609 510 884
- Switzerland:** Duc Lufttechnik GmbH, Mühlebachweg 9, 5620 BREMGARTEN, SWITZERLAND, tel +41 56 631 64 34
- Russia:** Ensto Rus, Vozduhoplavitelnaya Str. 19, 196 084 SAINT PETERSBURG, RUSSIA, tel +7 812 336 99 17
- Denmark:** Covent EMJ, Donsvej 55, 6052 VIUF, DENMARK, tel +45 7556 1288
- Belgium:** EUREKA CONFORT Belgium scrl, Avenue Comte Jean Dumonceau 23, 1390 GREZ-DOICEAU, BELGIUM, tel +32 10 84 3333
- France:** Ensto Industrie SAS, RD 916, 66170 NEFIACH, FRANCE, tel +33 (0)4 68 57 20 20



Saves Your Energy

Ensto Enervent Oy
Kipinätie 1
FIN-06150 Porvoo, Finland
Tel. +358 207 528 800
Fax. +358 207 528 844
enervent@ensto.com
www.enervent.fi