

# LTR-7-AC

PLANNING, INSTALLATION AND  
OPERATION INSTRUCTIONS



Kipinätie 1, 06150 BORGÅ FINLAND  
Phone +358 207 528 800, fax +358 207 528 844  
[www.enervent.fi](http://www.enervent.fi)

2007\_1

## MODEL

Before you begin reading, confirm the model of your appliance.  
These instructions cover the following models:

---

LTR-7-ACE

LTR-7-ACW

---

## EXPLANATION OF THE MARKS AND NUMBERS

AC Alternating current fans 560 W, 230 V.

E Electrical heating coil 4000 W (built-in), with over heating protection, built-in temperature sensor and regulator.

W Water heater (built-in), freeze protection, 2-way valve, valve actuator, duct temperature sensor and regulator.

On all models the ducting connections are Ø 250 mm.

---

## INTRODUCTION

All LTR-7-AC ventilation equipment has been designed for all year round use. In Finland the Enervent appliances have been installed in small premises and detached houses for over 20 years. The popularity of the appliances is increasing year by year. Using knowledge gained over the years, it has been possible to make the Pingvin range more and more user-friendly.

The LTR-7-AC range is the result of long-term product development. It is very versatile and variable.

With the help of this manual it is possible to install a appliance with basic functions yourself. We recommend that installation of ventilation units with special functions and extra equipment be carried out by a qualified electrician.

We recommend that a qualified ventilation engineer performs the installation work.

Before any maintenance of the appliance is carried out, please read the warning on page 5!



## GUARANTEE

Enervent Oy Ab admits a two (2) year product guarantee on the LTR-7-AC range. The guarantee covers the repair work with the necessary spare parts. Repair service will be carried out at the factory premises in Porvoo, Finland or as agreed.

The guarantee is not valid if the unit has been incorrectly installed, poorly maintained or mechanical damage has resulted from improper use. This guarantee does not compensate for losses indirectly caused by the use of the appliance, troubleshooting, installation after the repair or transportation.

Retain the receipt as proof of purchase, and for the start date of the guarantee period.

# TABLE OF CONTENTS

<b>MODEL</b>	page	<b>2</b>
<b>INTRODUCTION</b>		<b>3</b>
<b>GUARANTEE</b>		<b>3</b>
<b>TABLE OF CONTENTS</b>		<b>4</b>
<b>WARNING</b>		<b>5</b>
<b>1. OPERATING PRINCIPAL</b>		<b>5</b>
<b>2. INSTALLATION PARTS</b>		<b>6</b>
<b>3. PLANNING OF THE DUCT SYSTEM</b>		<b>8</b>
<b>4. EXTRACT AIR CLASSIFICATION OF LIVING AREAS</b>		<b>10</b>
<b>5. PHASES OF INSTALLATION</b>		<b>11</b>
<b>6. HEAT INSULATION OF AIR DUCTS</b>		<b>12</b>
<b>7. DESCRIPTION OF FUNCTIONS</b>		<b>13</b>
7.1 Controlling running and fan speeds		13
7.2 Regulating fan speeds		14
7.3 Using the heat recovery in the summer time		15
7.4 Defrosting of the heat recovery wheel		15
7.5 Heat recovery efficiency		15
7.6 Regulating temperatures		15
7.7 Over heating protection of the electrical heating coil		16
7.8 Freeze protection of the water heater		16
7.9 Damper motor regulation		17
7.10 Regulating the proportion of supply and exhaust air		17
7.11 Maintenance- och fault alarms		17
<b>8. FUNCTIONS OF THE CONTROL PANEL</b>		<b>18</b>
8.1 Normal state		18
8.2 Main menu		19
8.3 Fan speeds		20
8.4 Temperatures		21
8.5 CO <sub>2</sub> control		22
8.6 %RH control		23
8.7 Pressure control		24
8.8 Settings		25
8.9 Service menu		26
8.10 Setting the weekly timer		28
8.11 Explanation of the lights on the control panel		29
<b>9. AIR FLOW REFERENCE VALUES</b>		<b>30</b>
<b>10. KITCHEN VENTILATION</b>		<b>30</b>
<b>11. TO BE OBSERVED DURING OPERATION!</b>		<b>31</b>
<b>12. HEAT RECOVERY EFFICIENCY</b>		<b>31</b>
<b>13. MAINTENANCE</b>		<b>32</b>
<b>14. BELT INSPECTION AND REPLACEMENT</b>		<b>33</b>
<b>15. CHARACTERISTICS</b>		<b>34</b>
<b>16. WIRING DIAGRAMS</b>		<b>35</b>
16.1 Electrical wiring diagrams		35
16.2 COH and CVC indication		41
16.3 Outer cabling of the control		43
<b>17. FAULT / CORRECTION GUIDE</b>		<b>44</b>
<b>18. TECHNICAL DATA</b>		<b>45</b>

## WARNING

After opening the service hatch, wait for two (2) minutes before starting the maintenance work! Although the unit's power supply is cut when the hatch is opened, the fans still rotate and the electrical coil in E-models is still hot for a while.

There are no user-serviceable parts behind the control panel, contact a service technician for service and repairs of this part of the unit.

Clarify the cause of the fault before restarting the unit!

## 1. OPERATING PRINCIPLE

The LTR-7-AC ventilation unit is based on regenerative heat recovery. This is achieved with a rotating heat exchanger through the halves of which incoming air and exhaust air flow in opposite directions. Aluminium foils of the heat exchanger transfer heat from the exhaust air to the supply air.

A characteristic of the regenerative heat exchanger is its high rate of heat recovery.

The heating rate of the supply air varies from 75 % to 85 %, depending on the proportion of supply air and exhaust air (the heat from the supply air fan is taken into account). Thanks to its high heat recovery, LTR-7-AC saves heating energy at the same time as it takes care of a good indoor air quality; therefore it repays itself in a relatively short time.

## 2. INSTALLATION PARTS

### A. STANDARD PARTS

- LTR-7-AC ventilation unit (delivered with EU5 bag filters)
- Uninstalled control panel
- Water heater (built-in), control valve and valve actuator (ACW-models)



LTR-6- AC ventilation unit



Control valve and valve actuator (ACW-models)

### B. EXTRA EQUIPMENT

- Uninstalled control panel (max 1+4 panels can be attached to the automation)
- CO<sub>2</sub> carbon dioxide transmitter (max 2 transmitters can be attached to the automation)
- %RH humidity transmitter (max 2 transmitters can be attached to the automation)
- Pressure difference transmitter for the exhaust air filter (filter guard)
- Pressure difference transmitter for the ducts (constant pressure)
- Push button for over pressure control (for use in home mode)
- Push button for extend time control (for use in office mode)
- Silencers for the ducts
- Outside air and waste air dampers
- Damper motors (with spring return)
- Micro filter EU7 (built-in or duct installed)
- CW-cooling coil, (Ø160 mm for installation in duct), control valve, valve actuator, duct temperature sensor
- Evaporator (Ø160 mm for installation in duct)



%RH humidity transmitter



Control panel



CO<sub>2</sub> carbon dioxide transmitter

## C. ADDITIONAL EQUIPMENT

- Filter EU5
- Microfilter EU7 (built-in or duct installed)



Spare filter EU5

## 3. PLANNING OF THE DUCT SYSTEM

It is recommended that the task of dimensioning the duct system is given to a professional installer.

The ducts must be large enough, min. Ø 100 mm, to allow an sufficiently low air speed. In particular the outside feed and the waste air ducts need to be wide. The size of the outside air duct, waste air duct and the outside grille must be Ø 250 mm. Do not fit an insect net behind the grille.

Use only type approved materials, as galvanised spiral-weld or plastic pipe, for the duct system. Valves which are suitable for mechanical ventilation must be used. Valves with a diameter of 100 mm or larger are to be used for supply and exhaust air.

**The outside air** should be taken, if possible from the north side of the building or from a shady place where temperature variations are moderately small.

**The waste air** should be led out about 90 cm above the roof saddle. Use insulated factory made fittings. A cover must be installed on the end of the waste air duct to prevent rain water from entering the duct system.

To enable duct cleaning, a sufficient number of control hatches should be placed in the duct system. The control hatch locations could be marked for example on the roof trusses to make finding them easier.

**The extract air** valves are placed in the following premises: Toilet, kitchen, washroom, bathroom, clothing storage room, cleaning cupboard and utility room.

**The supply air** valves are placed in the following premises: bedroom, living room, separate dining recess, hobby room, dressing room and sauna. We recommend that a supply air valve is installed in the innermost corner of the sauna. The air flow from the valve should be directed above the stove.

The air from a room with supply air is supposed to flow through chinks of the doors or “free flow” door grilles to areas with exhaust air. Normally a 20 mm chink of the door is enough besides in the sauna where a 100 mm chink is needed. Additional supply air can be ducted directly to wood-burning fireplaces (in the sauna) from the outside. The duct must be closable.

Garages or workshops must not be connected into the ventilation equipment of the house; they should have their own extractor system or independent heat recovery unit.

The cooker extractor hood should not be connected into the house ventilation system. (Excess steam and grease will cause blockage of the heat exchanger).

A fan assisted drying cabinet can be connected indirectly to the extract valve (drying cabinet - valve attachment) which allows air from both the room and the cabinet to extract from the same valve. The volume through the extract air valve has to be at least 12 l/s.

**Silencers.** A hard silencer 09 is recommended for the extract duct, a silencer 09 or 06 is recommended for the supply air duct.

**The distances between waste air and fresh air openings.** Usually fresh air is taken from a north facing wall and the waste air is led out from the roof.

The diagram shows how to determine the distance between the outside feed into the house and the waste from the house.

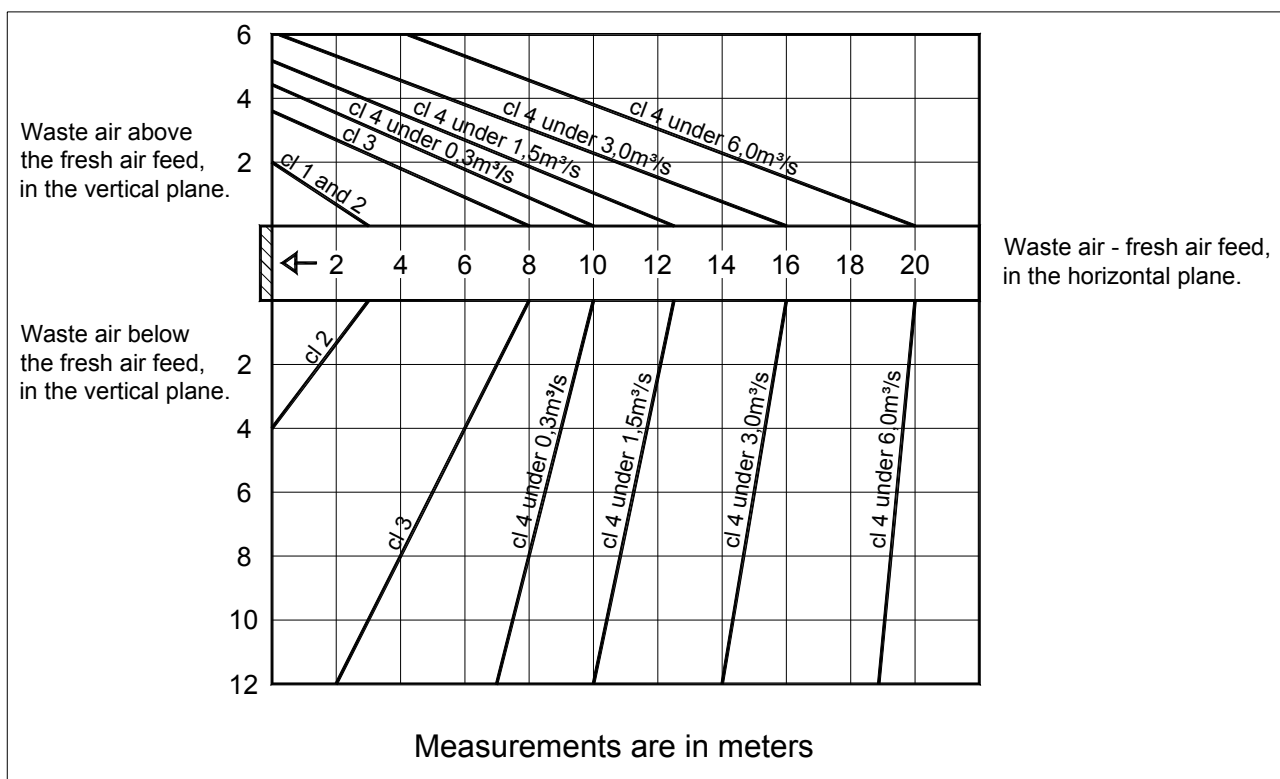

Other methods are acceptable, so long as they fall within the guidelines laid out by the Ministry of the Environment’s code of building regulations (D2: Finland 2003, extract shown below), or in accordance with your local directives and regulations governing indoor climate and building ventilation.



## 4. EXTRACT AIR CLASSIFICATION OF LIVING AREAS

The leading of waste air from a building is based on the following, extract air classification

- Class 1** Extract air which contains few impurities. The impurities are mainly from people or structures. Air is suitable for return air and transfer air.
- Class 2** Extract air which contains some impurities. The air is not used as return air of other premises but can be lead for example to the toilet and washing room as transfer air.
- Class 3** Extract air from premises where high humidity, processes, chemicals and smells essentially lower the quality of exhaust air. The air is not used as return air or transfer air.
- Class 4** Extract air which contains ill-smelling or unhealthy impurities considerably more than the acceptable contents of the indoor air. The air is not used as return air or transfer air.

### Examples of extract air class of living areas

- Class 1** Office rooms and small adjoining storage spaces, customer service and teaching premises, meeting and business premises which are non-odorous.
- Class 2** Living rooms, dining recesses, coffee kitchens, shops, warehouses of office buildings, dressing rooms and restaurant premises where smoking is forbidden.
- Class 3** Toilets, washing rooms, saunas, apartment kitchens, distribution and teaching kitchens, copying premises of drawings.
- Class 4** Professionally used fume cupboards, grilles and target exhaust air from kitchens, car garages and driving tunnels, handling rooms of paints and solvent, dirty wash laundries, store rooms of waste food, chemical laboratories, smoking rooms, hotel and restaurant premises where smoking is permitted.

(Finland's building regulations D2 2003)

## 5. PHASES OF INSTALLATION

The unit can be installed in a warm, half warm or cold room. If the unit is installed in a cold room, must it be equipped with a 100 mm thick cover of isolation. The unit can be installed i.e. in a storage room or on an attic.

The unit should be placed on a plain surface on a elastic material that muffle sound. For instance a 100 mm thick isolation plate is suited as bedding. The unit can be mounted on its edge, so that the front edge is higher than the back edge.

If the unit is used to ventilate a facility with a swimming pool it must be drained. There are two (2) drain outlets of which the other should be taken it to use, depending of the position of the unit. At the time of delivery, both outlets are plugged.

Phases of installation:

- A. Place the unit on the isolation plate (i.e. a chipboard covered with 100 mm isolation) or in a storage room or on the attic on a custom made shelf. Take into consideration the possible drain.
- B. Check that there is at least 60 cm of free space in front of the service hatch and that the electrical inlets are accessible. Take into consideration that opening the lock bolts requires a certain amount of space.
- C. Connect the ducts to the tubes on the unit. It is recommended that silencers be installed to the exhaust air and supply air ducts. Silencers, see page 8.
- F. If the unit's condensation drain is to be used, connect a pipe between the drain outlet and the nearest floor drain or water trap of a sink. Connecting the unit directly into the sewage system is not allowed. If the unit is installed in a cold room the drain pipe must be isolated so it doesn't freeze.

N.B.! To reduce the weight of the unit remove the rotor before mounting on the wall.

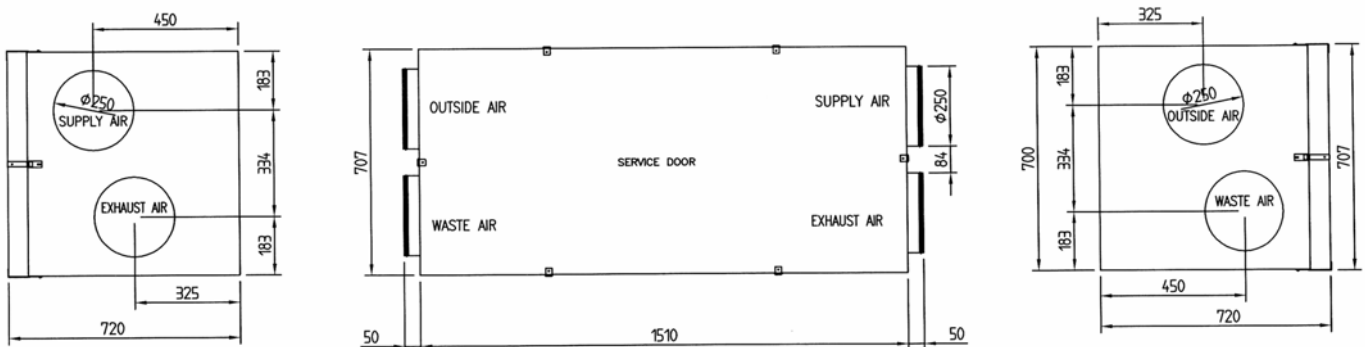

All LTR-7 models

## 6. HEAT INSULATION OF THE DUCTING SYSTEM

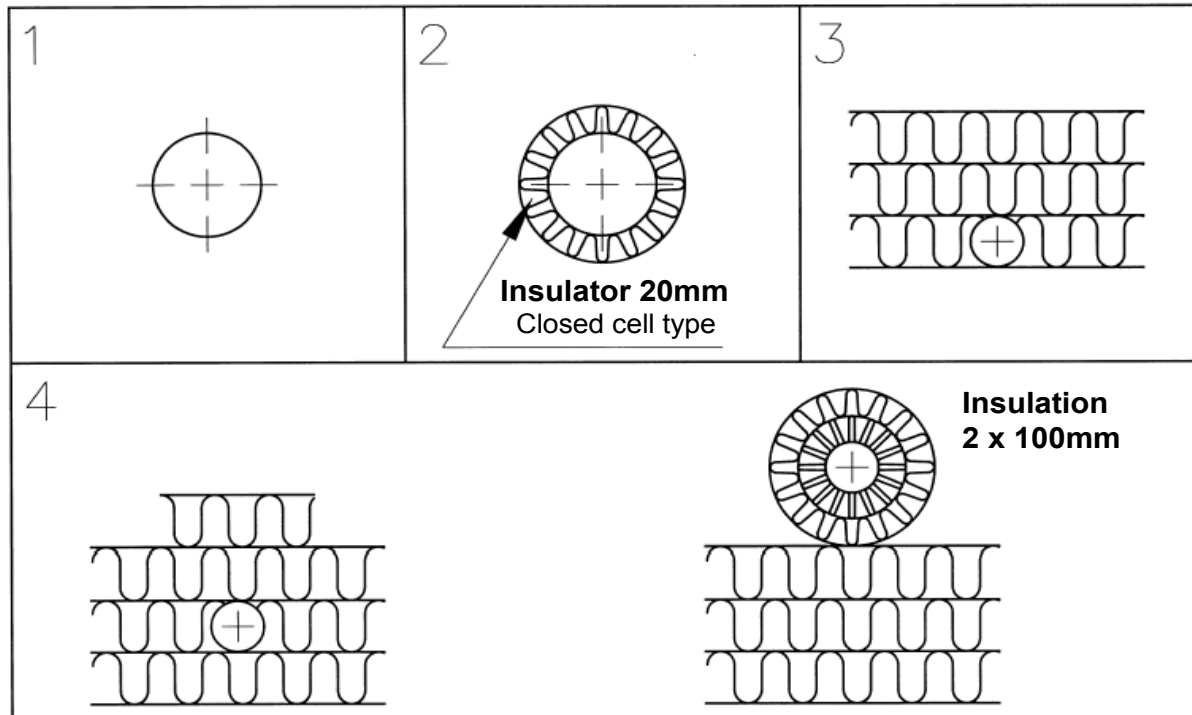

The figure shows different examples of ductwork insulation.

1. Extract air duct in warm state (indoor, no insulation).
2. Waste air duct and fresh air duct in warm state (indoor).  
Insulation, for example Armaflex™
3. Extract air duct on attic under the insulation but above the steam barrier.
4. All air ducts on a cold attic. The waste or fresh air ducts must not be installed immediately above the steam barrier; there should be a mineral wool insulating layer of at least 100 mm between them.

## 7. DESCRIPTION OF FUNCTIONS

### LTR-7-AC control panel

1. Heat recovery button / scroll upwards / increase numeric value
2. Heater control button / scroll downwards / decrease numeric value
3. Menu / enter button, access to main menu , verify changes
4. HRW indicator light
5. Heater control indicator light
6. Maintenance / fault indicator light
7. Display

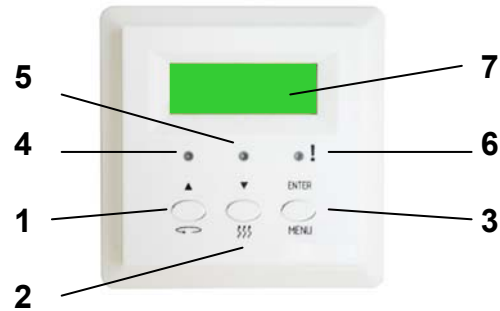

### 7.1 CONTROLLING RUNNING AND FAN SPEEDS

When the unit is turned on, the extract air fan starts first and then the heat recovery exchanger. About one minute later the supply air fan starts. The unit always starts on minimum effect. After this the fan speed is regulated from the control panel, by the air quality sensors or by an outer electrical signal i.e. from the range hood or central vacuum cleaner.

The fan speeds can also be regulated with a weekly timer, so that the fan speeds are at a specific level at a specific time. This way the fans can be set to run on a lower speed i.e. when the apartment is empty. There are eight (8) speeds for each fan to choose from.

It is possible to turn off the fans for a certain time using the weekly timer, if the automation is set on "office mode". In that case there must be dampers (extra equipment) in the outside air and waste air ducts that stop cold air from flowing inside. In spite of the weekly timer program, the fans can be started again for a certain time by pushing an extended time button. In the "office mode" the outer electrical controls are not possible.

The following circumstances affect the fan speeds:

- Boosting, over pressure control and extended time control.
- The fan speed is automatically set to speed 1 if the supply air is too cold.
- If there is a problem with the heat exchanger, the supply air fan automatically stops and the exhaust air fan is set on speed 1.
- Restrictive guidance from the range hood or central vacuum cleaner (constant pressure).
- Summer night cooling

The following is valid according to model:

ACE-models: The fans stop if the over heating protection goes off (setting off is manual).

ACW-models: The fans stop if the freeze protection goes off.

## **7.2 REGULATING FAN SPEEDS**

### **Carbon dioxide and humidity control**

The fans are controlled with the help of the information gathered by the CO<sub>2</sub> and RH% sensors in the ventilated premises. Two (2) carbon dioxide and two (2) humidity sensors (extra equipments) can be attached to the automation.

The goal is to keep the CO<sub>2</sub> and/or the RH% level beneath the preset value. If no outer humidity sensor is attached, the fan speeds are controlled by the one built-in humidity sensor in the ventilation unit. This function must be activated in the RH% menu on the control panel.

The maximum fan speeds of the air quality control are programmed in to the control panel.

### **Constant pressure control**

The goal is to keep the pressure level constant in the apartment, despite starting the range hood or central vacuum cleaner. The benefit of keeping the pressure constant is i.e. that the fireplace burns better.

The constant pressure control requires a separate electrical signal from the range hood and the central vacuum cleaner. The constant pressure control can be deactivated from the control panel. This function is possible only in home mode.

### **Over pressure control**

This function allows us to create a momentary over pressure in the apartment, which makes lighting the fire easier. The over pressure can be activated from the control panel or from a separate push button (extra equipment). The duration of the over pressure and the fan speeds during it, is programmed in to the control panel. The functions can be deactivated from the control panel. Over pressure control is possible only in home mode.

### **Boosting**

Boosting is activated from the control panel. Boosting increases the speed of both fans for a given time, according to the values (efficiency and time) set in the control panel.

The boosting function can be deactivated from the control panel. Boosting can be active simultaneously with the constant pressure control and/or the over pressure control. Boosting is possible in both office and home mode.

### **Extended time control**

It is possible to start the unit on so called extended time, after the weekly timer has shut down the ventilation unit in office mode. The duration of the extended time is set on the control panel. The extended time control is activated either from the control panel or from a separate push button (extra equipment). The extended time control can be deactivated from the control panel. This function is possible only in office mode.

### **Constant pressure**

Two pressure-difference transmitters 0-10 V / 24 V (extra equipment) can be attached to the control panel. They measure the pressure in the supply and extract air ducts and the pressure is kept constant by changing the fan speeds if needed.

## 7.3 USING THE HEAT RECOVERY IN THE SUMMER TIME

### Efficiency reduction

The heat recovery can be turned off in the summertime, if the outside air temperature exceed the limit set for HRW SUMMER (possible settings +10 ... +20°C, factory setting +18°C). During the efficiency reduction, the heat recovery wheel stands still. During the stand still the heat recovery wheel rotates for ten (10) seconds every two hours to prevent dust from collecting on the wheel (automatic purging operation).

The recovery wheel also stops automatically if the supply air, extract air or room temperature, depending on chosen function, exceeds the set value with 3°C ( $\pm 1^\circ\text{C}$ ). The following additional clauses have to be fulfilled: the extract air temperature is 3°C ( $\pm 1^\circ$ ) warmer than the outside air and the outside air temperature exceeds the set HRW SUMMER value.

The HRW automatic purging operation is not active in office mode, when the unit is shut down by the weekly timer.

### Cool recovery

(! shines green and the HRW-light is lit)

During the efficiency reduction in the summertime the recovery wheel rotates continuously when the outside air temperature is 3°C higher than the extract air temperature. The recovery wheel stops, when the outside air temperature is 1°C higher than the extract air temperature.

## 7.4 DEFROSTING OF THE HEAT EXCHANGER

The controller instructs the supply air fan to work periodically, based on the temperatures of the extract air and the outside air together with the humidity content of the extractair, to prevent the heat recovery wheel from freezing. When the defrosting is active, the waste air temperature (at sensor TE31) is kept between the set values. The extract air fan works normally when the risc of freezing is over for the recovery wheel. The defrosting can be deactivated from the control panel.

## 7.5 HEAT EXCHANGER EFFICIENCY

The heat recovery efficiency of the supply air is shown in percent on the control panel.

## 7.6 TEMPERATURE REGULATION

### Constant supply air temperature

The controller regulates the efficiency of the electrical or water heater, based on the information given by the supply air temperature sensor (TE10), in order to keep the supply air temperature at the set value  $\pm 1^\circ\text{C}$  (possible settings +15° ... +25°C). In addition there is a possibility of 0-10 V outlet for cooling control.

### Constant room temperature

The controller regulates the efficiency of the electrical or water heater, based on the information given by the temperature sensor (TE20) in the control panel, in order to keep the room temperature at the set value  $\pm 1^\circ\text{C}$  (possible settings +15° ... +25°C). If several control panels are attached, the mean value of the results from the panels is counted and used as the current value. If one of the panels is installed in a much warmer or colder

space, a temperature correction can be done for its measuring or alternatively its result can be left out totally. The supply air max and min temperature is restricted at the sensor. In addition there is a possibility of 0-10 V outlet for cooling control.

### **Constant exhaust air temperature**

The controller regulates the efficiency of the electrical or water heater, based on the information given by the extract air temperature sensor (TE30), in order to keep the extract air temperature at the set value  $\pm 1^{\circ}\text{C}$  (possible settings  $+15^{\circ}\dots+25^{\circ}\text{C}$ ). In addition there is a possibility of 0-10 V outlet for cooling control. The supply air max and min temperature is restricted at the sensor. In addition there is a possibility of 0-10 V outlet for cooling control.

The after heating is programmed to function only if the heat recovery is on and the controller requests heating. The after cooling is on only if the controller requests cooling. The heating and the cooling are never on at the same time. Neither the heating nor the cooling is on if the unit is turned off by the weekly timer in office mode.

### **Summer night cooling**

(! shines green)

During the summer it is possible to lower the room temperature by letting cool air flow inside at night. When using summer night cooling, the real cooling, heat recovery and heating are not active. The fan speeds are controlled as programmed in the preset program. Even if one should have chosen different speeds for the fans, the fans work on normal speed during summer night cooling.

The summer night cooling is automatic. It is active only between 22.00 and 7.00.

## **7.7 OVER HEATING PROTECTION OF THE ELECTRICAL HEATER (ACE-models)**

The thermostat TZ+ controls the temperature of the electrical heater. If the temperature exceeds i.e.  $+50^{\circ}\text{C}$  ( $\pm 4^{\circ}\text{C}$ ) the electrical supply to the heater is automatically cut off, but the fans remain on. The electrical supply is automatically restored when the temperature has dropped to  $+39^{\circ}\text{C}$  ( $\pm 4^{\circ}\text{C}$ ).

The temperature limiter TZA+ also controls the temperature of the electrical heater. If the temperature exceeds i.e.  $+75^{\circ}\text{C}$  ( $\pm 4^{\circ}\text{C}$ ), the over heating protection goes off and the power supply to the heater is cut.

Setting off the over heating protection is manual. When TZA+ goes off it prohibits the heating relay from pulling and stops the fans.

## **7.8 FREEZE PROTECTION OF THE WATER HEATER (ACW-models)**

If the return water temperature drops beneath  $+10^{\circ}\text{C}$  while the unit is on, the automation starts opening the control valve. If the return water temperature drops beneath  $+5^{\circ}\text{C}$  although the control valve is fully open, the freeze protection goes off and the control stops the fans and gives an alarm.

If a return water temperature sensor is not installed, the fans will not start and an alarm is given.

## **7.9 DAMPER MOTOR CONTROL**

The dampers, FV1 and FV2 (extra equipment), motors M (extra equipment) are controlled side by side. The dampers are open when the fans are on. The damper motors have spring returns and are de-energized when the dampers are closed.

## **7.10 REGULATING THE PROPORTION OF SUPPLY AIR AND EXHAUST AIR**

The exhaust air flow should be at least 10 % greater than the supply air flow. This is performed by accurately measuring the air flow through all of the vents with for example a thermo anemometer and by adjusting them to the correctly calculated values. A correctly balanced system returns a good heat recovery rate and keeps a slight negative pressure in the building. The negative pressure keeps the humidity away from the structures. When an adjustment is made, the filters must be clean and all the valves and outer grilles must be in place. There must not be an insect net over the fresh air grille.

## **7.11 MAINTENANCE AND FAULT ALARMS**

### **Filters**

Every fourth month the ! sign (orange) automatically lits up on the operating panel as a reminder that the filters should be changed.

### **Heat recovery**

The heat recovery wheel alarms if the recovery efficiency considerably decreases due to malfunction (the ! sign flashes red). The supply air fan is turned off and the exhaust air fan is turned to speed 1. When the defrosting of the heat exchanger is active, an alarm is not given.

### **Temperatures**

If the supply air temperature exceeds or falls short of the set action limit the ! sign shines orange.

If the extract air temperature falls short of the set action limit the ! sign shines orange.

If the supply air is too cold, the supply and extract air fans are switched to speed 1.

### **Electrical heater (The ACE-models)**

When the electrical heater temperature limiter (TZA+) goes off, an alarm is given (the ! sign flashes red)

### **Water heater (the ACW models)**

When the freeze protection of the water heater goes off, an alarm is given (the ! sign flashes red)

**All alarms are also shown in text on the control panel. When an alarm is given, the control panel goes over to showing it.**



## 8. FUNCTIONS OF THE CONTROL PANEL

### 8.1 NORMAL STATE

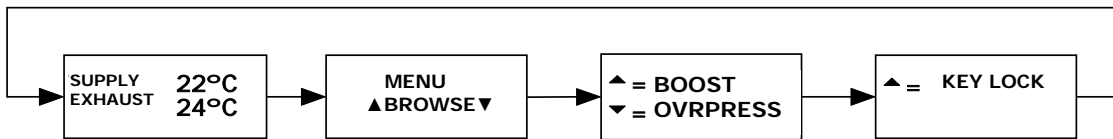

Chart 1. The normal state and the functions available in it at home mode

In normal state a basic display like the one in chart 1. is shown. The basic display contains of two lines which values can be chosen depending on what values one wants to observe, i.e. temperature or recovery efficiency. For more information about the basic display see the Settings-menu / Choose the basic display.

When the menu button is pressed again and again the windows in chart 1 appear one by one. Their functions are:

#### 1. MENU / BROWSE

Entering the main menu is done by pressing up or down in this window. For more information see the item Main menu.

#### 2. BOOSTING / OVERPRESSURE

The boosting function momentarily makes the ventilaiton more effective, which is useful i.e. after sauna or shower. The boosting function is activated and deactivated with the ▲-button. When the boosting function is active, "BOOST" is shown on the lower line on the display. The duration and fan speeds for the boosting is chosen in the Fan speeds-menu.

The unit is equipped with an overpressure function, which i.e. makes it easier to light a fire in the fireplace. Fore more information see the Pressure control-menu. The over pressure is activated by pressing the ▼-button. This function is possible only in home mode. In office mode the overpressure function is replaced with the extended time function. Fore more information see the Fan speeds menu.

#### 3. KEY LOCK

The ▲-button activates the key lock. It might be a good idea to have the keys locked to prevent unintended use. Press menu>menu>menu>▲ to unlock the key lock.

## 8.2 MAIN MENU

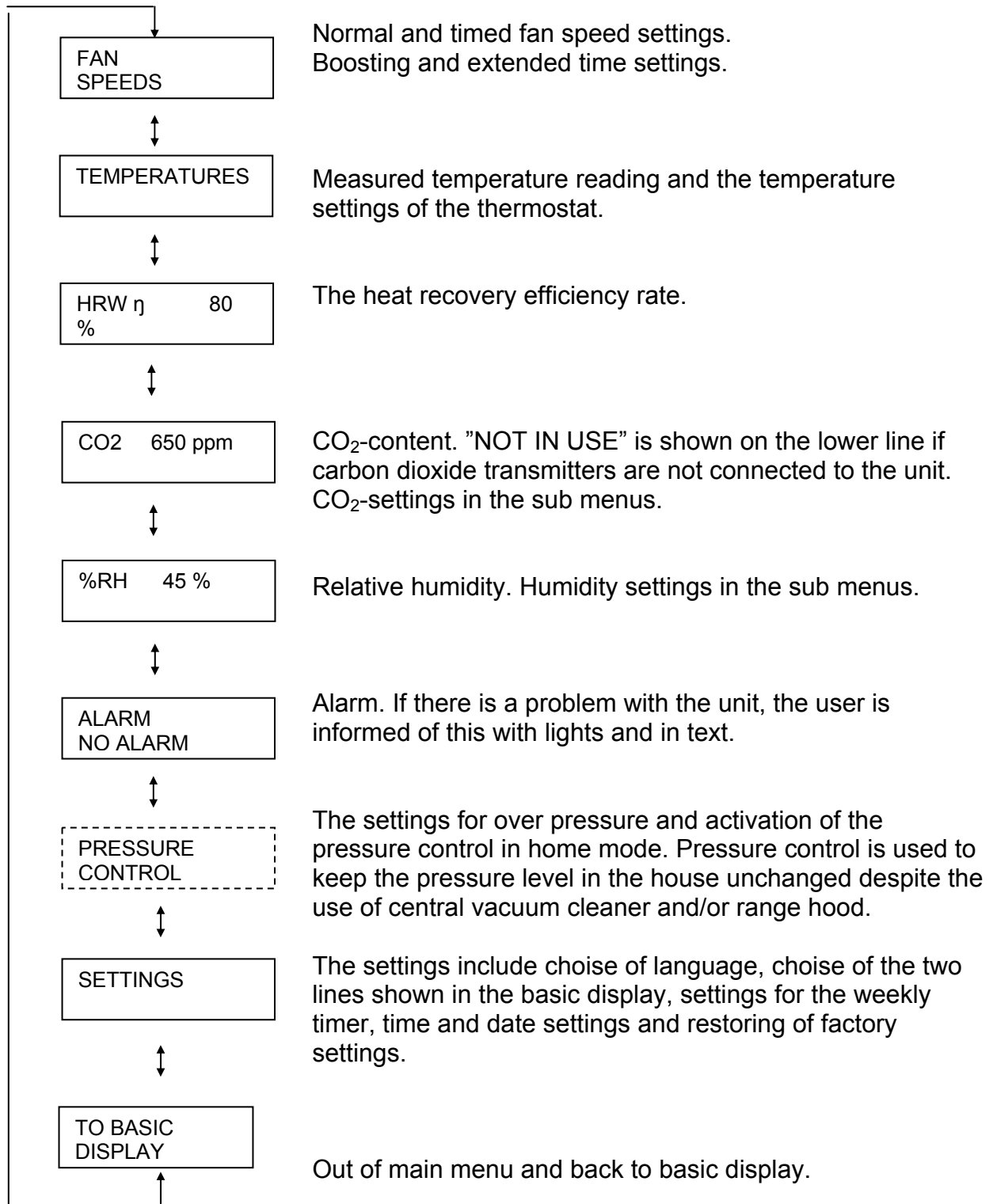

### 8.3 FAN SPEEDS

The following menu is available for fan speed settings:

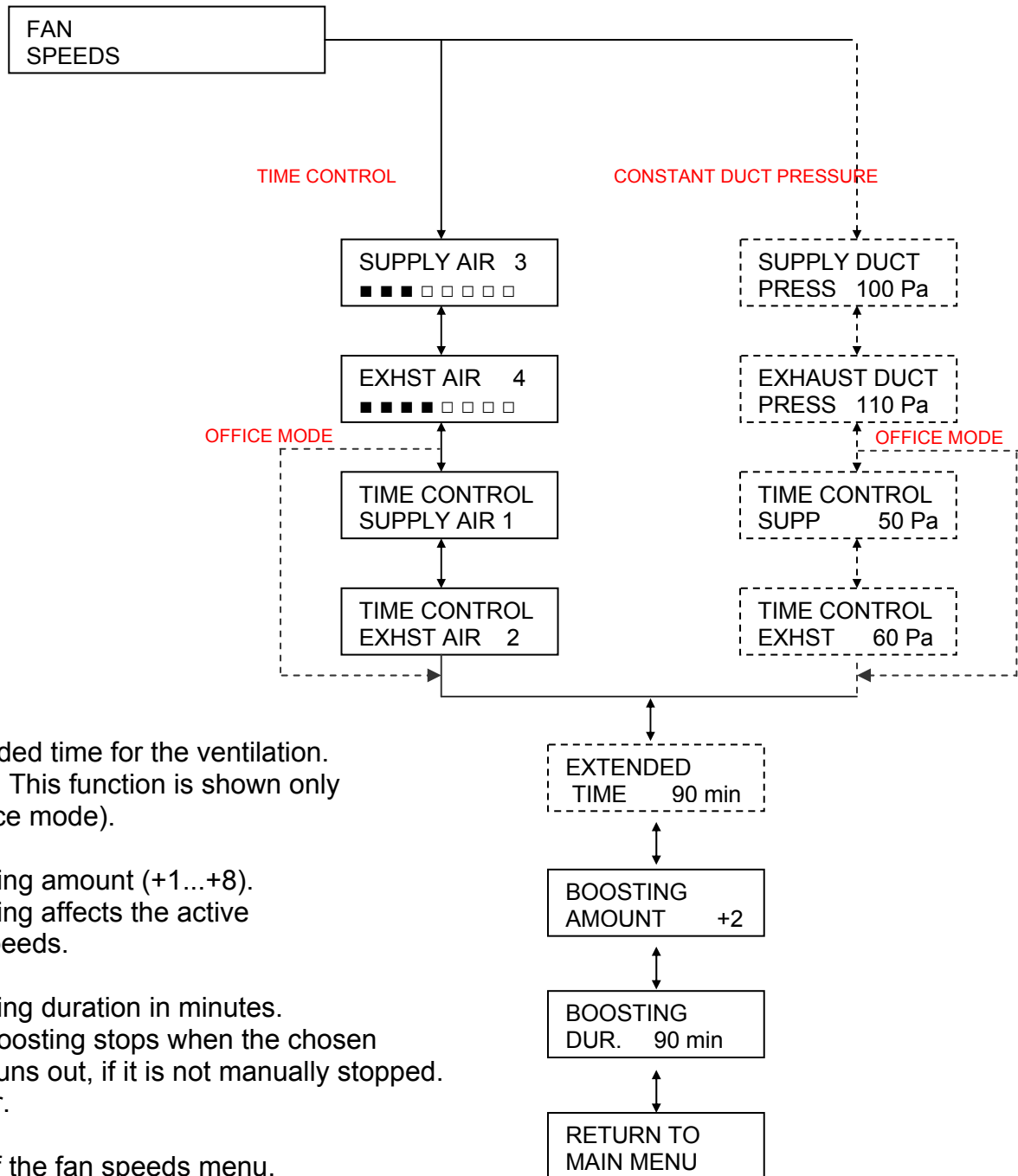

Extended time for the ventilation.  
(Note! This function is shown only in office mode).

Boosting amount (+1...+8).  
Boosting affects the active fan speeds.

Boosting duration in minutes.  
The boosting stops when the chosen time runs out, if it is not manually stopped earlier.

Out of the fan speeds menu.

## 8.4 TEMPERATURES

The following menu is available for fan temperature settings:

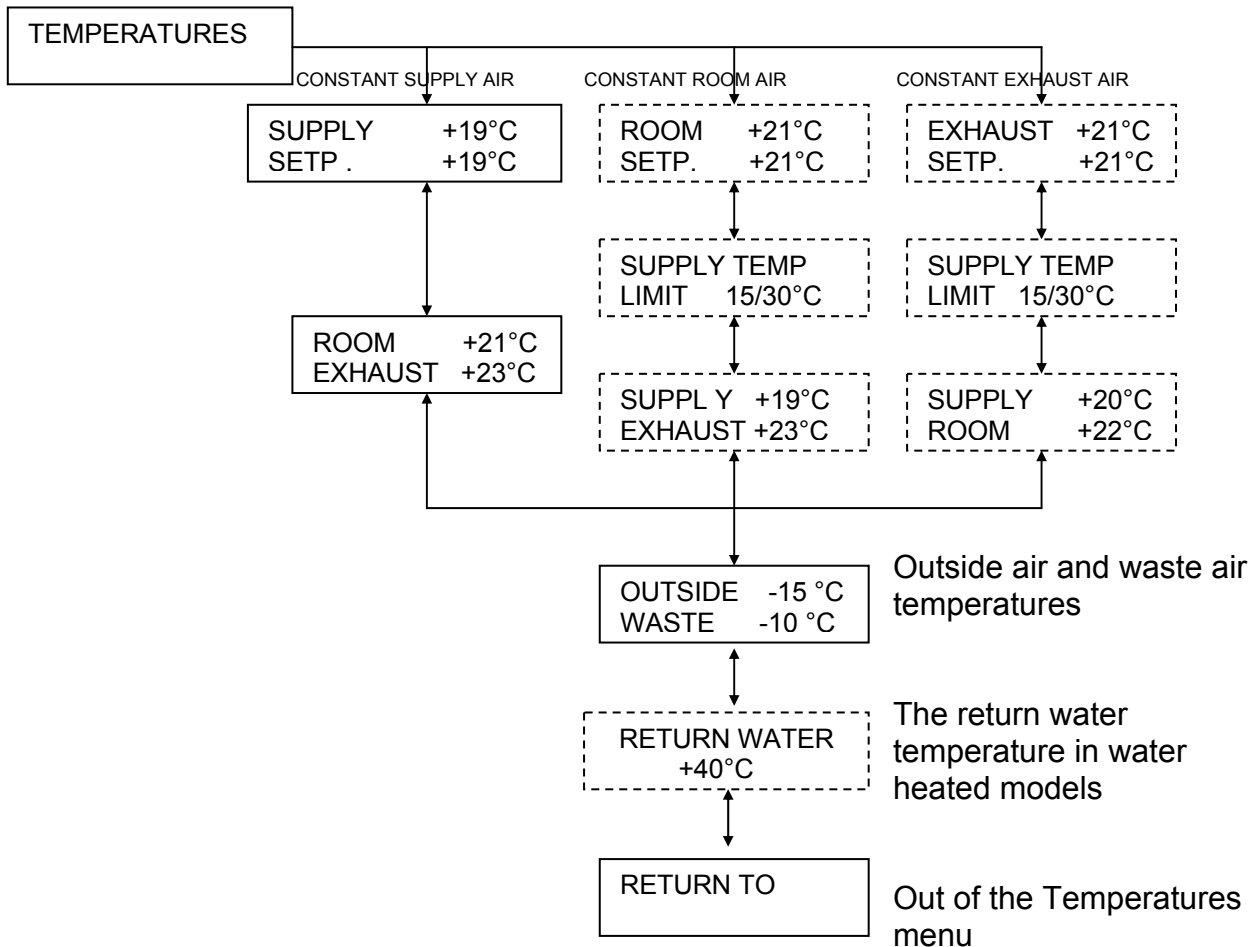

SETP. Desired supply air, room or exhaust air temperature, depending on which temperature regulation mode that is chosen in the maintenance menu

SUPPLY The supply air temperature

ROOM The room temperature

EXTRACT The extract air temperature

SUPPLY TEMP

LIMIT Supply air minimum and maximum temperature limit at constant room or exhaust air settings

## 8.5 CO<sub>2</sub> CONTROL

The following menu is available for CO<sub>2</sub> control:

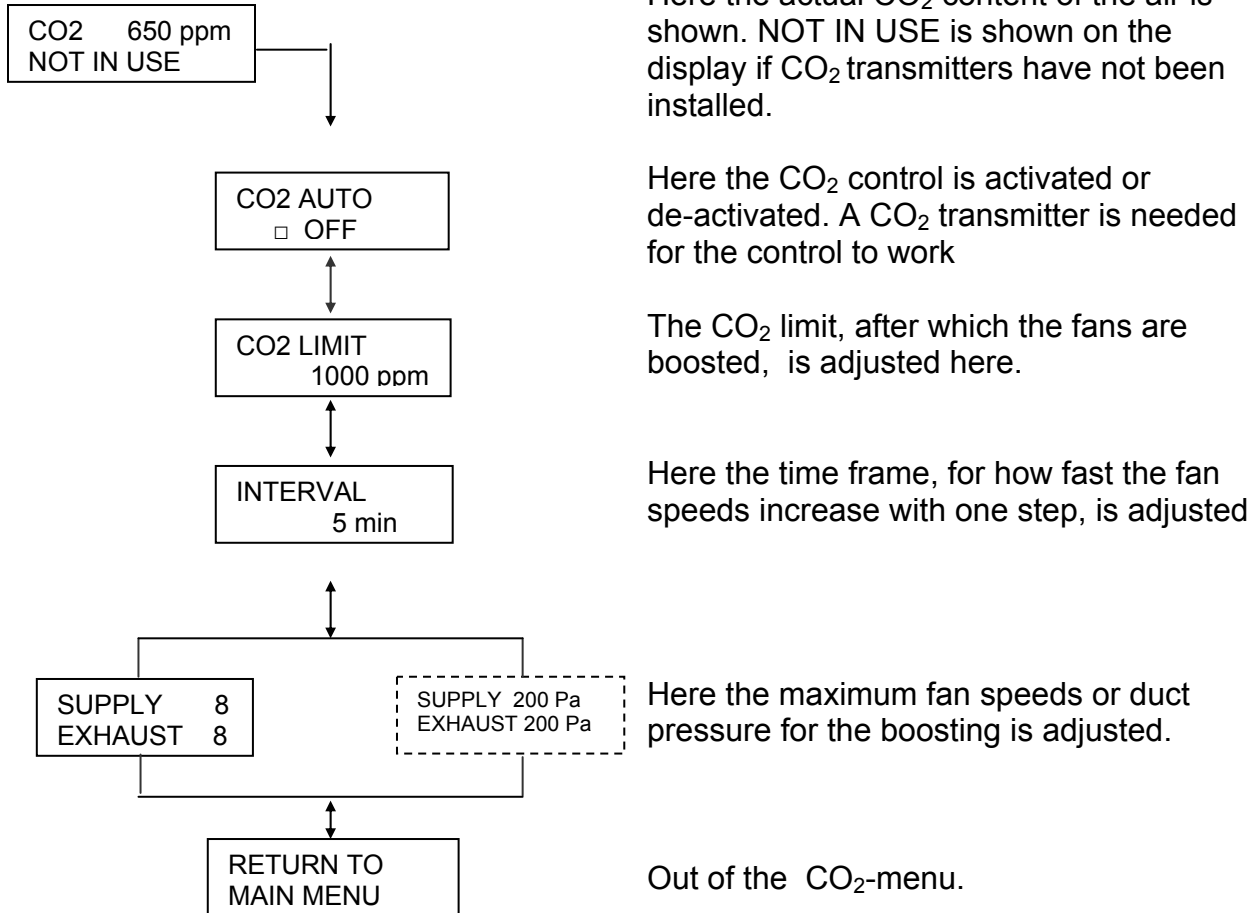

## 8.6 %RH CONTROL

The following menu is available for %RH control:

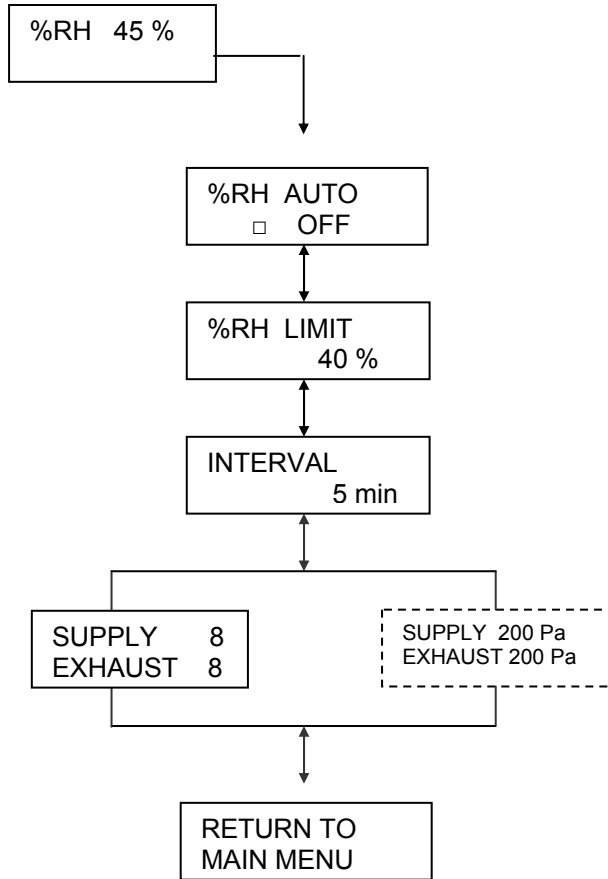

Here the actual relative humidity of the air in the house is shown. If several humidity transmitters have been installed, the highest value is shown.

Here the %RH control is activated or deactivated.

The %RH limit after which the fans are boosted is adjusted here.

Here the timeframe, for how fast the fan speeds increase with one step, is adjusted.

Here the maximum fan speeds or duct pressure for the boosting is set.

Out of the %RH menu.

## 8.7 PRESSURE CONTROL

The following menu is available for pressure control in home mode:

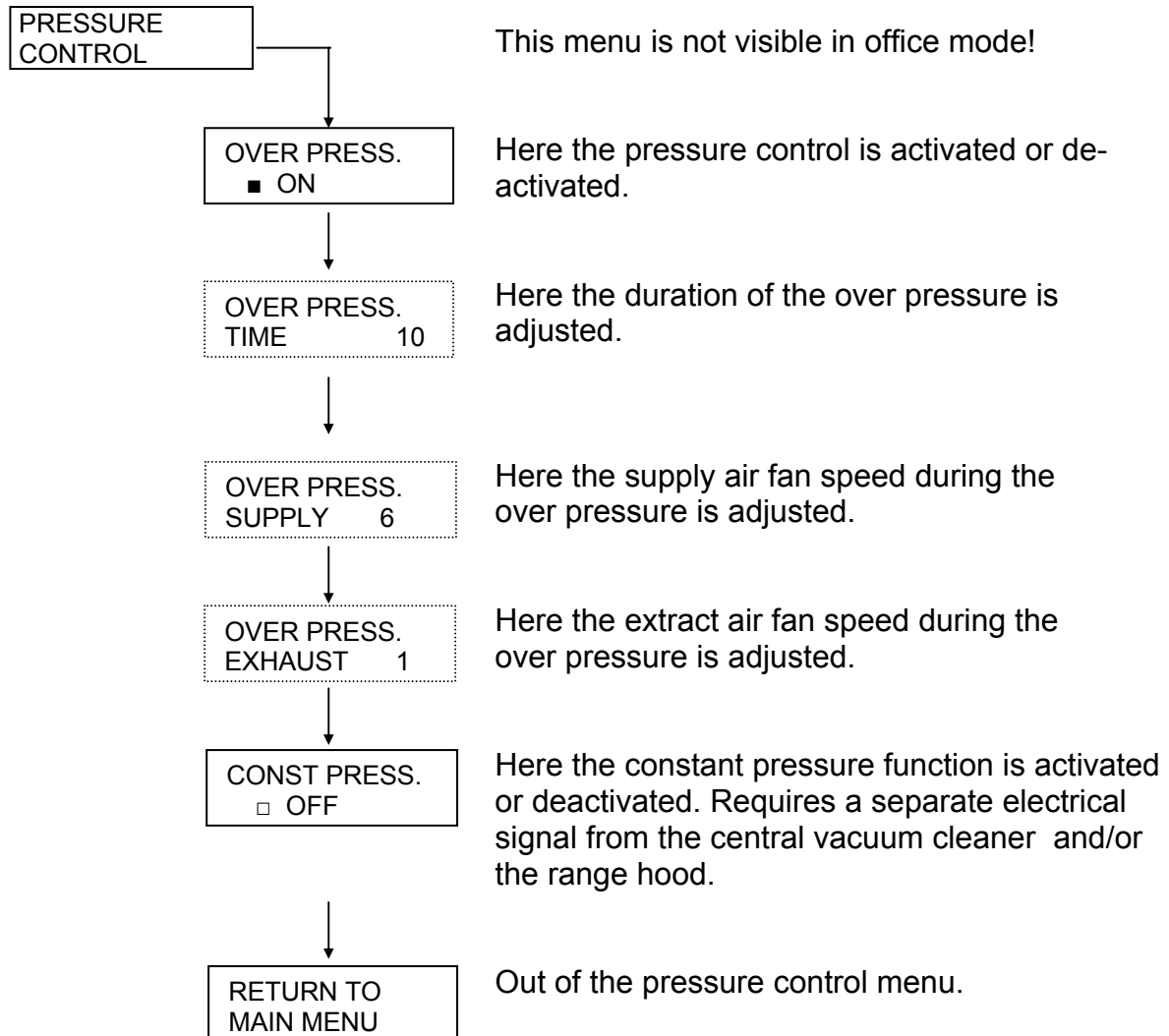

### NOTE!

The heat recovery efficiency decreases when the over pressure and the constant pressure functions are active. This is due to the fact that the supply air increases in proportion to the extract air. This means that the supply air temperature decreases after the HRW. The ventilation units after heating (electrical or water) strives to keep the supply air temperature at the adjusted set value.

Use the range hood only when preparing food – and save heating energy!

## 8.8 SETTINGS

The following menu is available for the settings:

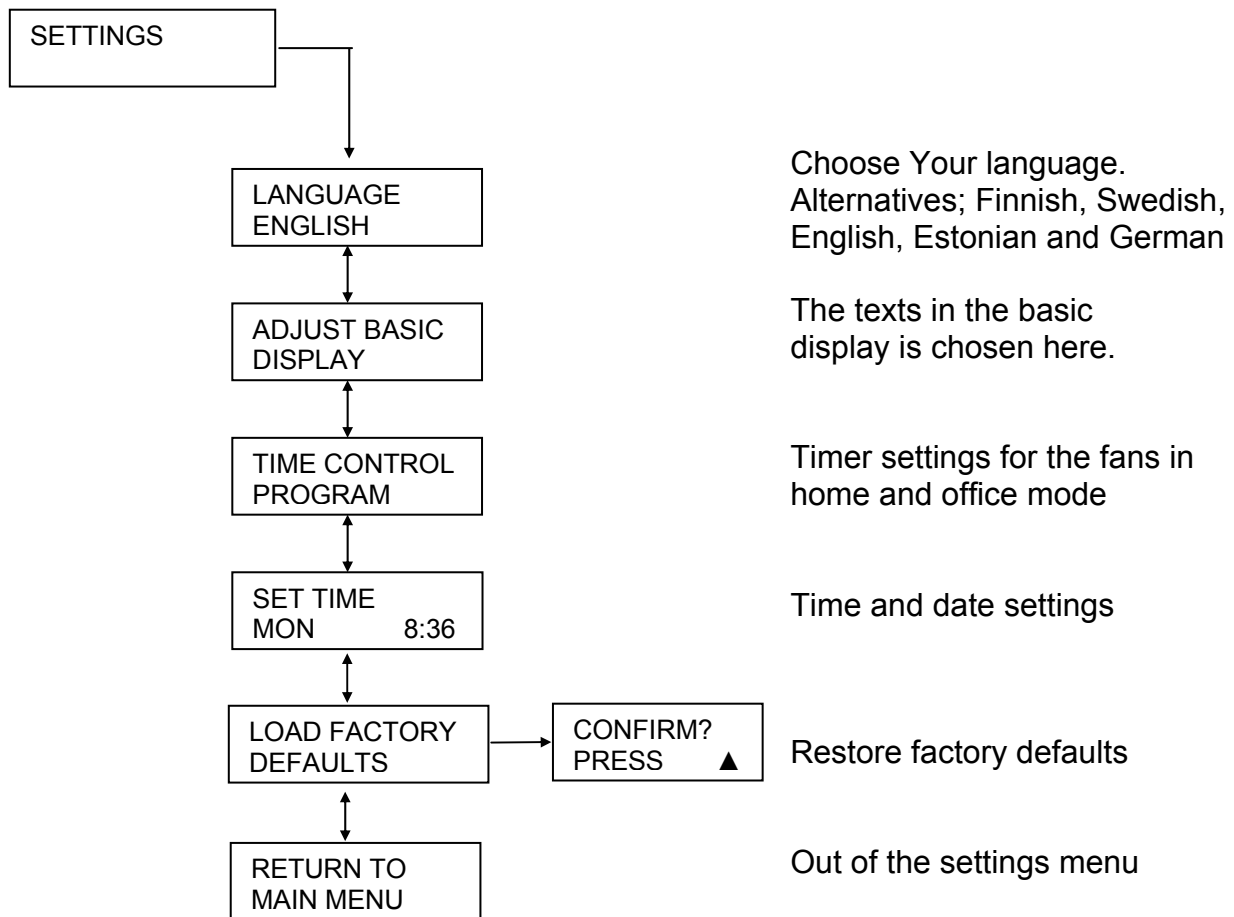



## 8.9 SERVICE MENU

The following menu is available for parameters that seldomly change:

The maintenance menu is entered by waiting 15 sec. at Settings and pressing ▲. Then press ENTER and give the code 6143.

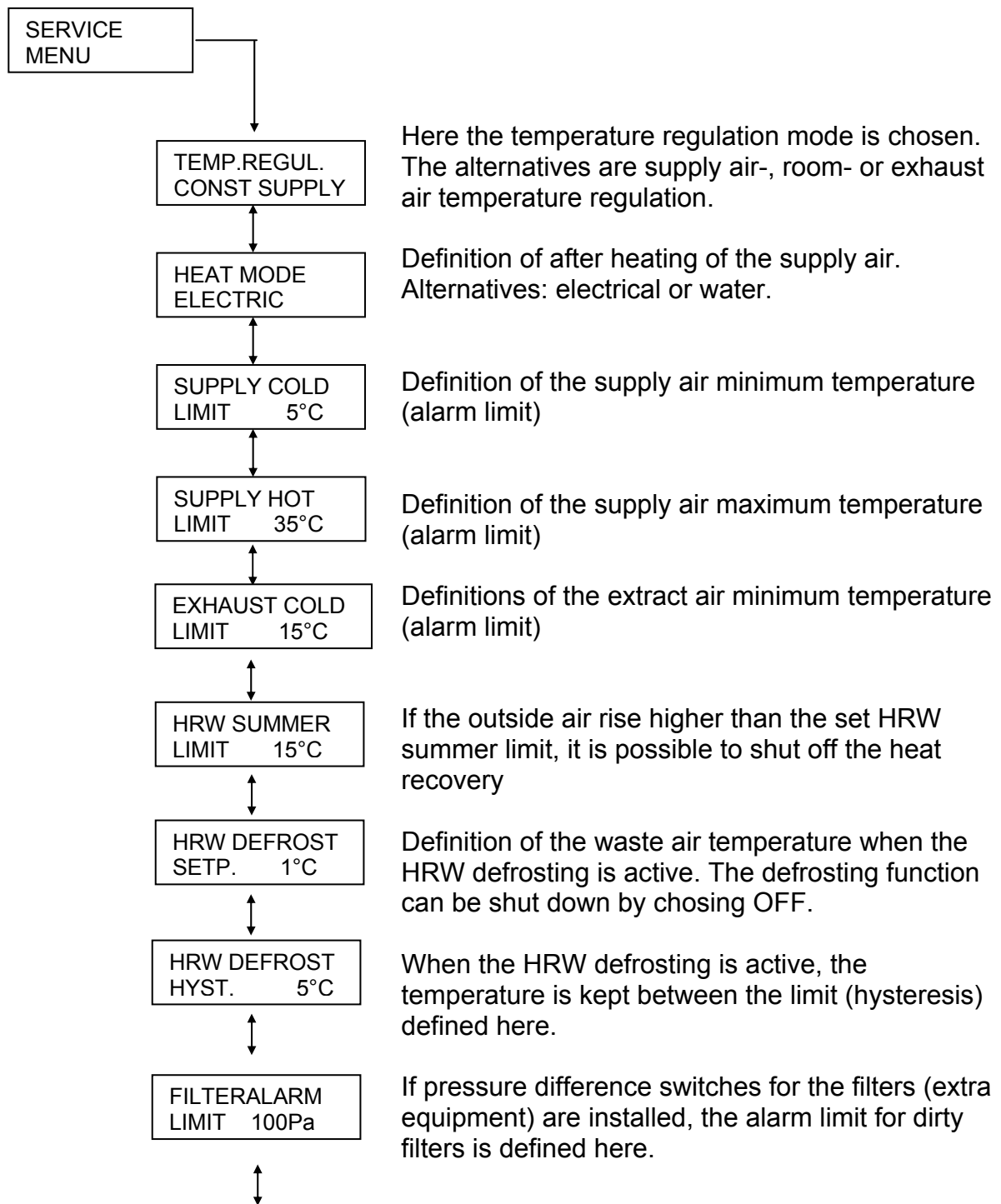

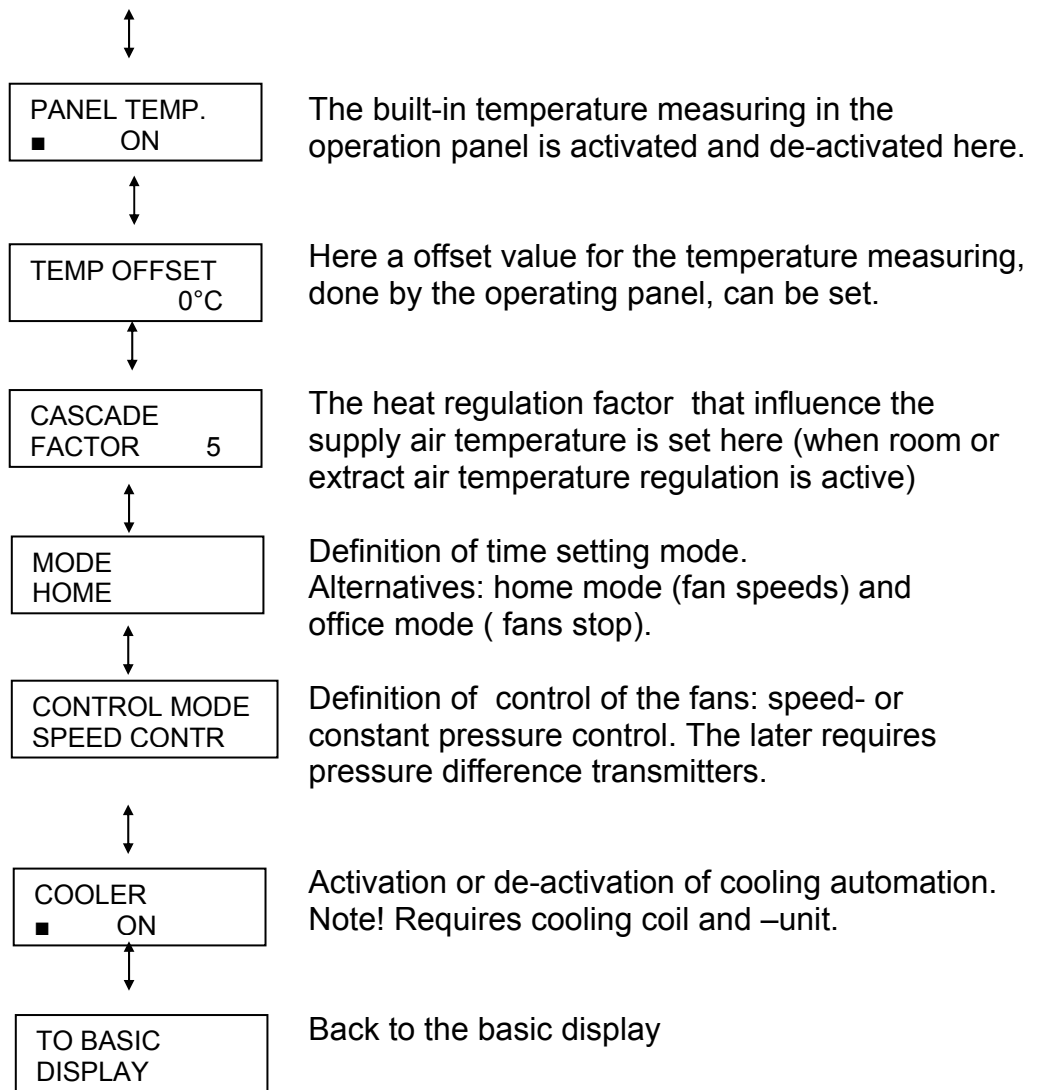

## 8.10 SETTING THE WEEKLY TIMER

The weekly timer allows the user to programme the fans to run at a certain speed, a certain day at a certain time. The weekly timer is in the SETTINGS-menu. The desired fan speed is defined in the FAN SPEEDS-menu.

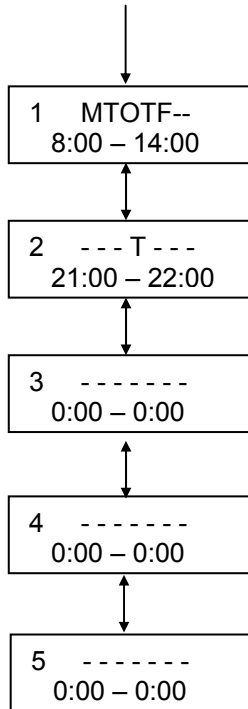

For example: The fans are programmed to run on desired speed Monday – Friday 08:00- 14:00.

For example: in addition the fans run at the desired speed Thursdays 21:00 – 22:00.

The weekly timer allows five different programme kombination.

## 8.11 EXPLANATION OF THE LIGHTS ON THE CONTROL PANEL

Light	HRW indicator light	Heater control indicator light	Maintenance / fault indicator light
Off	Heat exchanger does not rotate.	Heating regulation not in use. The unit does not heat or cool down the supply air.	No faults or warnings.
Green	Heat exchanger rotates.	Heating regulation active. The unit is heating or cooling down the supply air according to the function of the thermostat.	Summer night cooling or recovery of coolness active.  (Also lights for a moment when programming of the control panel is started.)
Orange	-	-	Warning <ul style="list-style-type: none"> <li>• Cold supply air</li> <li>• Hot supply air</li> <li>• Cold exhaust air</li> <li>• Filter</li> </ul>
Red	-	-	Fault <ul style="list-style-type: none"> <li>• Heat exchanger</li> <li>• Water heater / cooler</li> <li>• Electrical heater</li> </ul>
Red	-	-	(Programming of messages)

## 9. TARGET VALUES FOR AIR FLOWS

Target values for air flows in the living areas.

### EXTRACT AIR

Kitchen	20	l/s
Bathroom	15 –17	l/s
Toilet	10 –12	l/s
Clothing room	3 –4	l/s
Hobby room	0,7	l/s, m <sup>2</sup>
Dressing room	2,0	l/s, m <sup>2</sup>
Washroom	15 –17	l/s
Cleaning cupboard	4,0	l/s, m <sup>2</sup>
Utility room	15 –17	l/s

### SUPPLY AIR

Living room	8 –17 l/s	0,5 l/s, m <sup>2</sup>
Bedroom	5 –8 l/s	0,7 l/s, m <sup>2</sup>
Sauna	8 –17 l/s	2,0 l/s, m <sup>2</sup>
Separate dining recess		0,5 l/s, m <sup>2</sup>
Hobby room		0,7 l/s, m <sup>2</sup>
Dressing room		2,0 l/s, m <sup>2</sup>

## 10. KITCHEN VENTILATION

A normal cooker hood is installed over the kitchen stove. The hood should be used only when cooking. It is still necessary to install an extract vent, connected into the general ventilation system. The extract air volume should be 20 l/s.

The cooker hood should not be connected to the ventilation unit.

## 11. TO BE OBSERVED DURING OPERATION!

**Always ventilate with a high enough efficiency!** Otherwise the indoor humidity will rise too high and condensation will form on for instance cold window surfaces.

The recommended relative humidity for indoor air is 40 ...45 % (room temperature 20...22 °C). At these levels condensation will not form and the humidity is at a healthy level. By monitoring the humidity of the indoor air with a humidity sensor, the ventilation can be increased when the humidity rises over 45%. Alternatively the ventilation can be reduced if the humidity of the indoor air falls below 40%.

**Change the filters often enough!** During the winter time the extract air filter becomes dirty more quickly than the fresh air filter. In this case the extract air flow will decrease, which then leads to a rise in the humidity, and also the decline of the incoming air temperature. With every filter inspection / change, check that the heat exchanger functions correctly.

## 12. HEAT RECOVERY EFFICIENCY

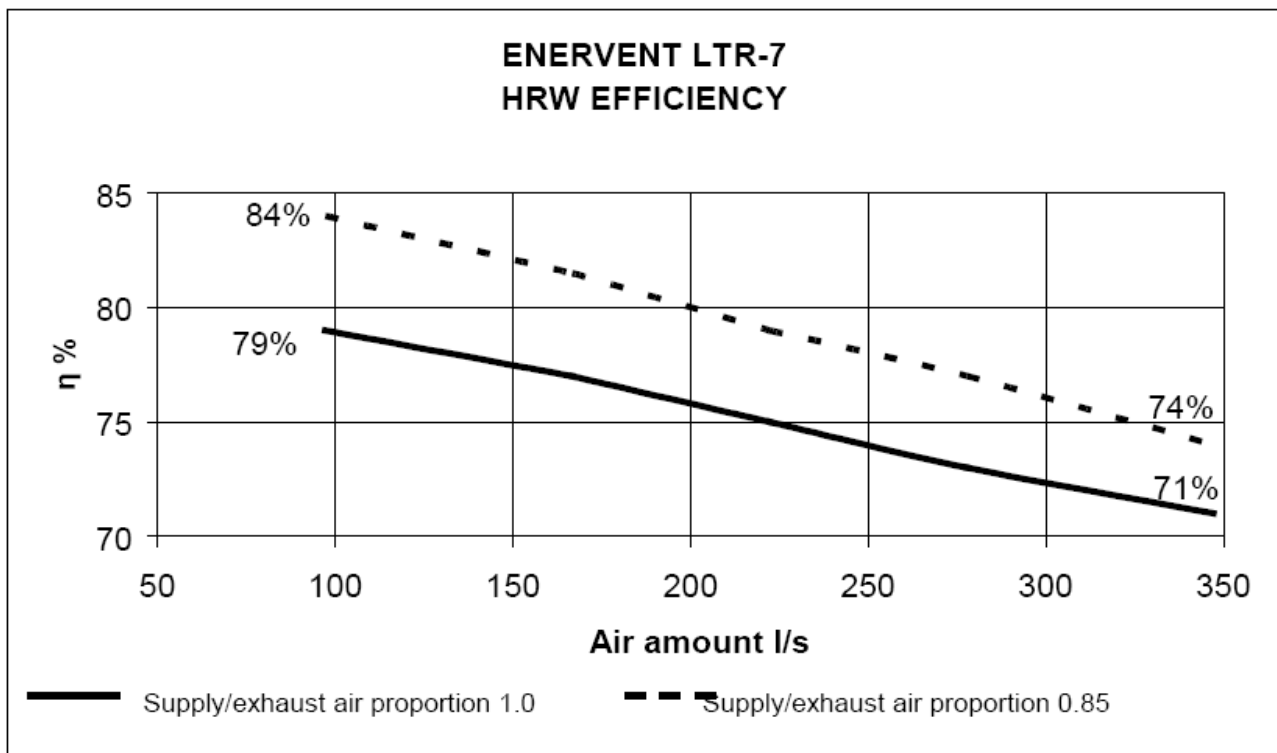

## 13. MAINTENANCE

LTR-7-AC does not require any mechanical maintenance, only changing of the filters periodically and cleaning of the heat exchanger and fans (when needed). The power supply to the unit is cut when the service hatch is opened. Wait for two (2) minutes before starting the maintenance work! Although the units power supply is cut when the hatch is opened, the fans still rotate and the electrical coil in E-models is still hot for a while. The hatch is opened by releasing the lock bolts.

**Cleaning the heat exchanger.** When changing the filters, check the condition of the heat exchanger. If cleaning is required, remove it from the machine and carefully wash through the air channels with a hand shower using a neutral detergent. The heat exchanger can also be cleaned by blowing through the air channels using compressed air. Do not use a pressure washer and do not submerge the heat exchanger into water!! When restarting the unit after cleaning, check that the rotor is turning freely.

**Cleaning the fans.** When changing filters, also check the condition of the fans. If cleaning is needed the fans are removed from the device and cleaned with a toothbrush or compressed air.

**Changing of filters.** The recommended time between filters changes is max six (6) months. Draw the filter from the device. Press the new filter into the machine. Vacuum-cleaning the inside of the device is recommended at this point.

## 14. BELT REPLACEMENT

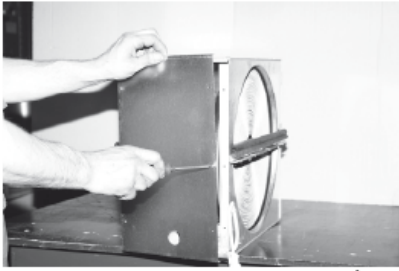

pic 1



pic 2



pic 3

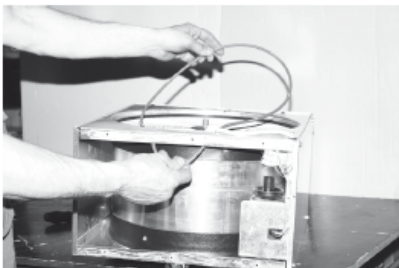

pic 4

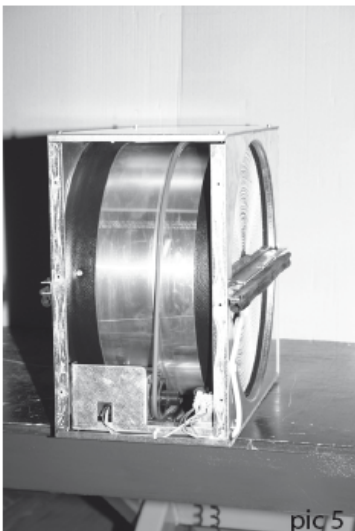

pic 5

The ventilation unit is stopped by switching off the main supply from the main switch, fuse or by disconnecting the wall plug.

Open the service hatch.

Disconnect the heat recovery wheel plug.  
Pull the heat exchanger out from the ventilation unit.

Open the screws in the side of the heat exchanger and lift off the hatch (pic 1).

Lay down the heat exchanger on it's side.

Turn the heat exchanger on the table so that the rotor shaft is in vertical position. Pull of the sealing rubber (pic 2).

Open the hexagonal screw from the end of the shaft and the two screws from the u-profile.

Lift off the u-profile.

Clean the outside of the heat exchanger and thrill the belt carefully inside the heat exchanger through the gasket. Simultaneously rotate the heat exchanger carefully (pic 3 and 4).

Fasten the u-profile with the two screws and the hexagonal screw.

Push the seling rubber on it's place.

Turn the heat exchanger upwards and put the belt on the wheel (pic 5).

Rotate the heat exchanger couple revolutions upwards seen from the motor.

Clean the package inside.

Fasten the hatch with the screws.

Install the heat exchanger back to the ventilation unit and connect the plug.

Shut the service hatch.

Switch on the main supply.

NOTE! All new units are delivered with a spare belt, which is fastened on the heat recovery wheel.



# 15. CHARACTERISTICS

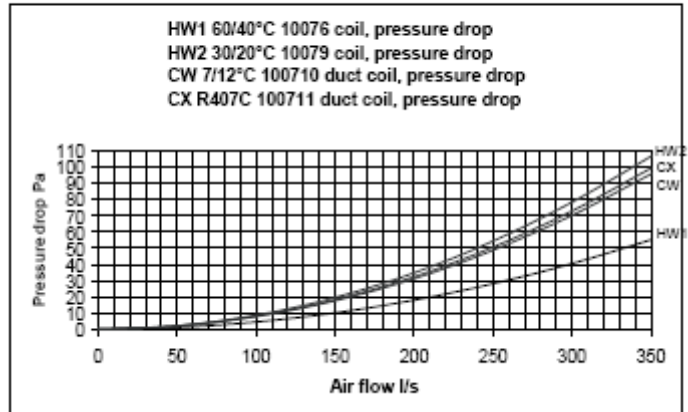
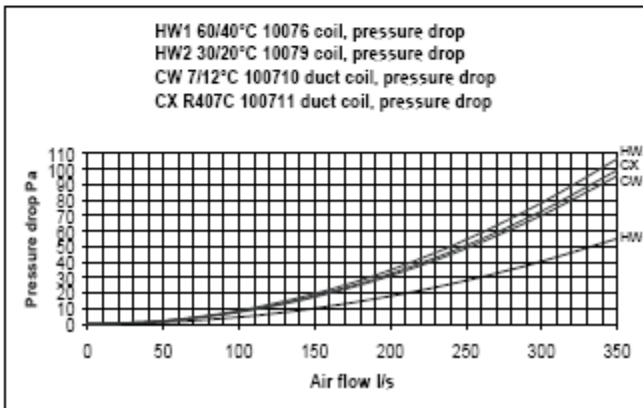
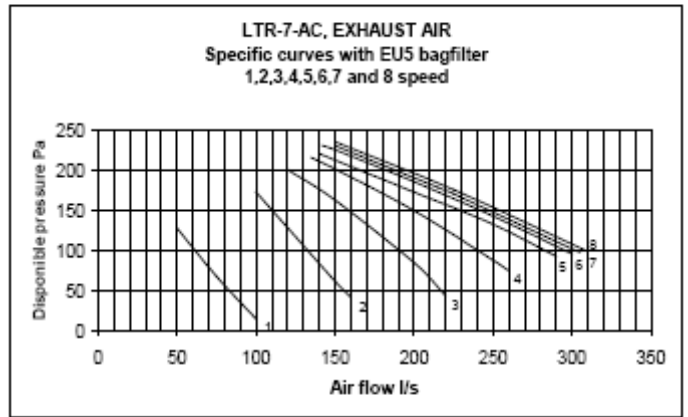
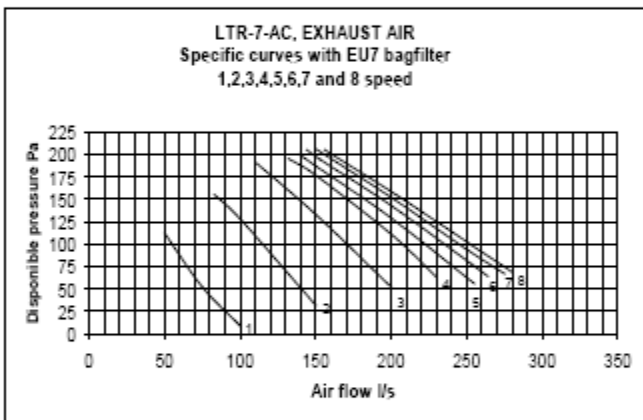
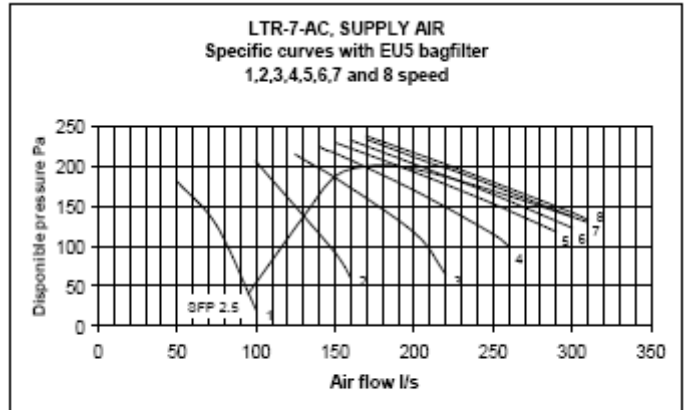
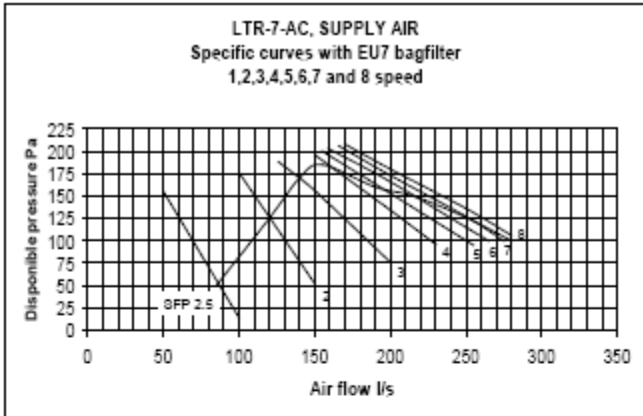

# 16. WIRING DIAGRAMS

## 16.1 ELECTRICAL WIRING DIAGRAMS

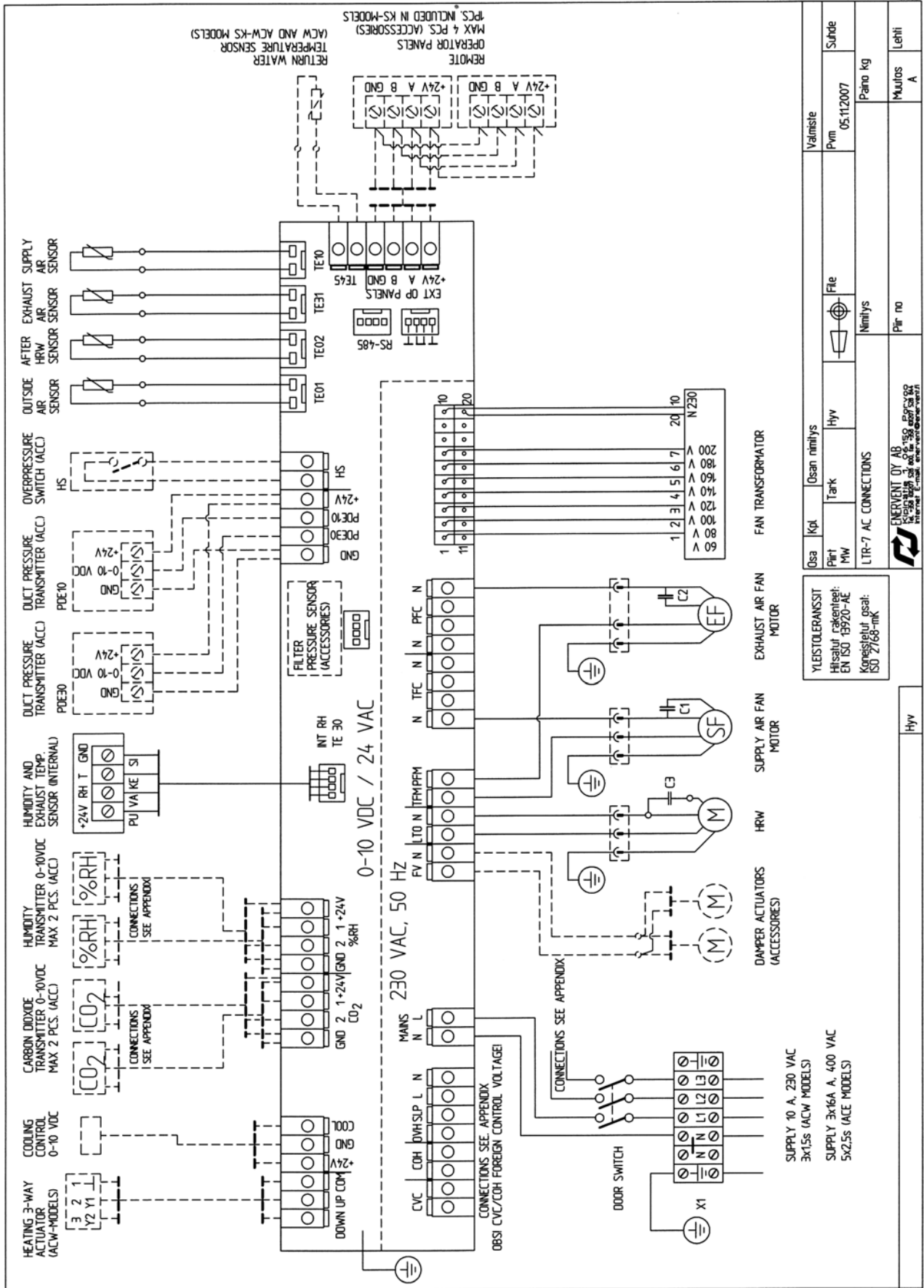

YLESTOLERANSSIT				Dosa		Kpl	Osaan nimitys		Välmistä	
Hissalut rakenteet: EN ISO 15920-AE				Parit MW	Tark	Hyv	Nimitys		File	Suhde
Koneselut osat: ISO 2768-mk				LTR-7 AC CONNECTIONS				Paino kg		05.11.2007
				Per no		A		Muuos		Lehti
				Hyv						

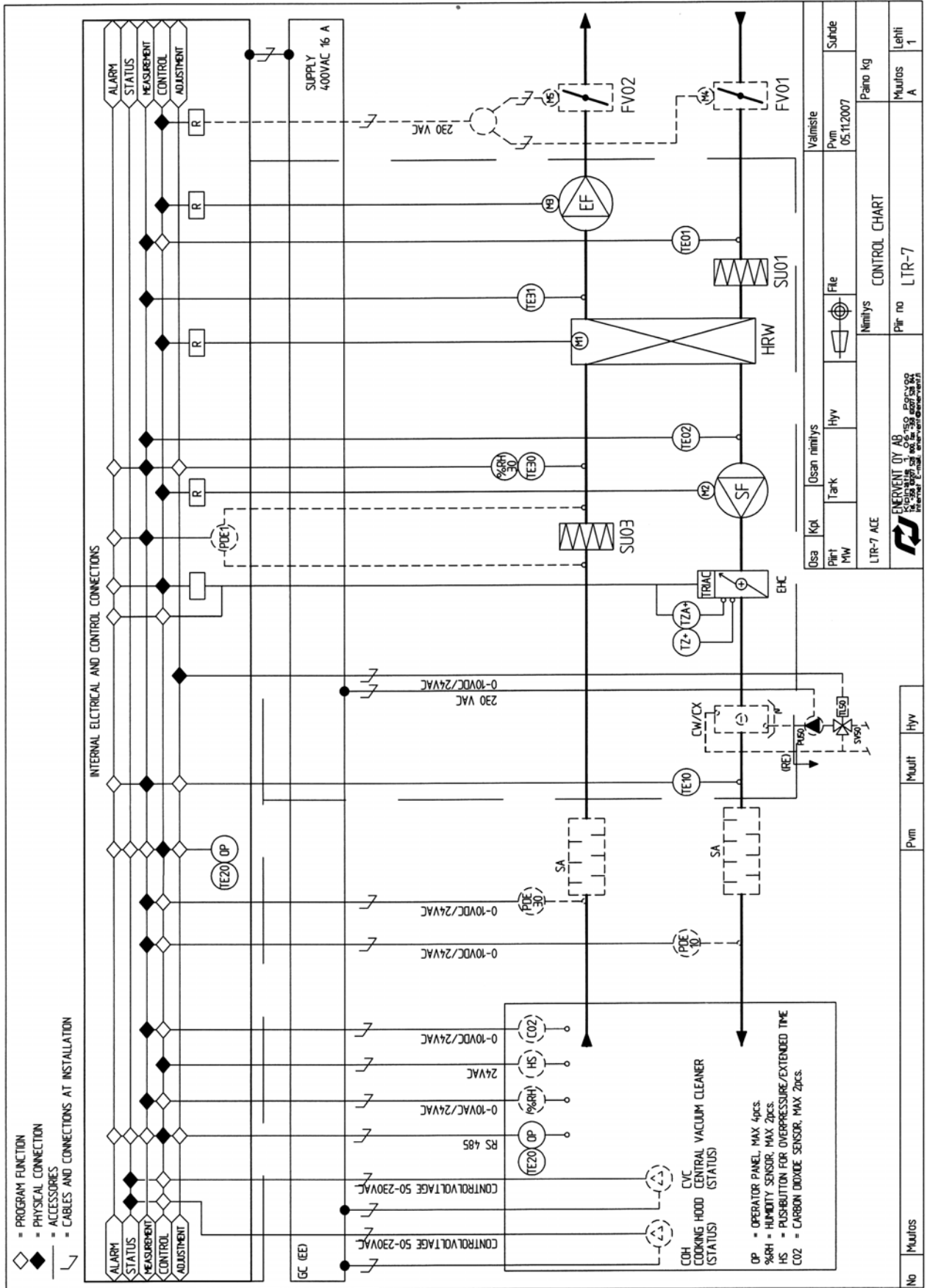

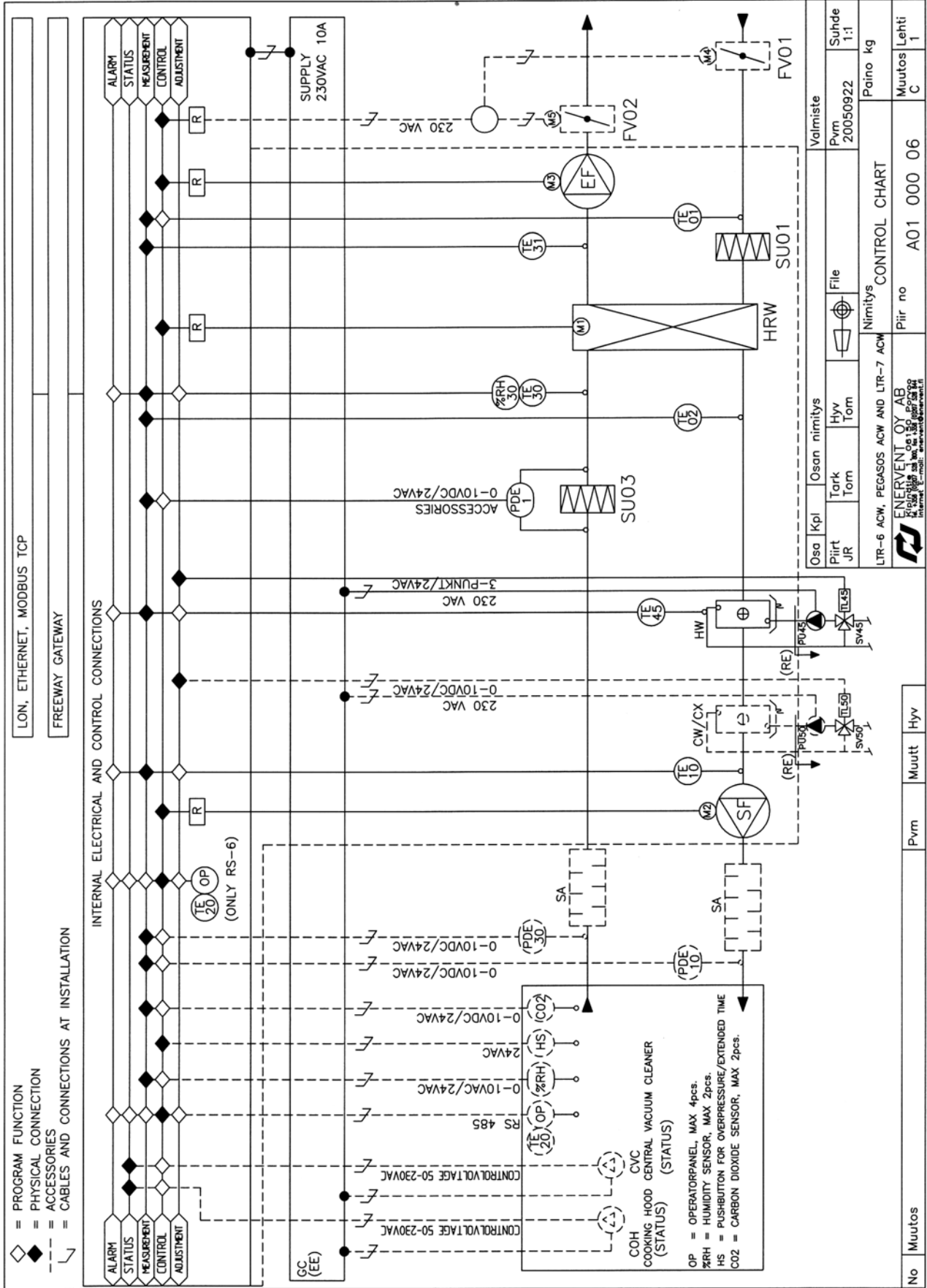

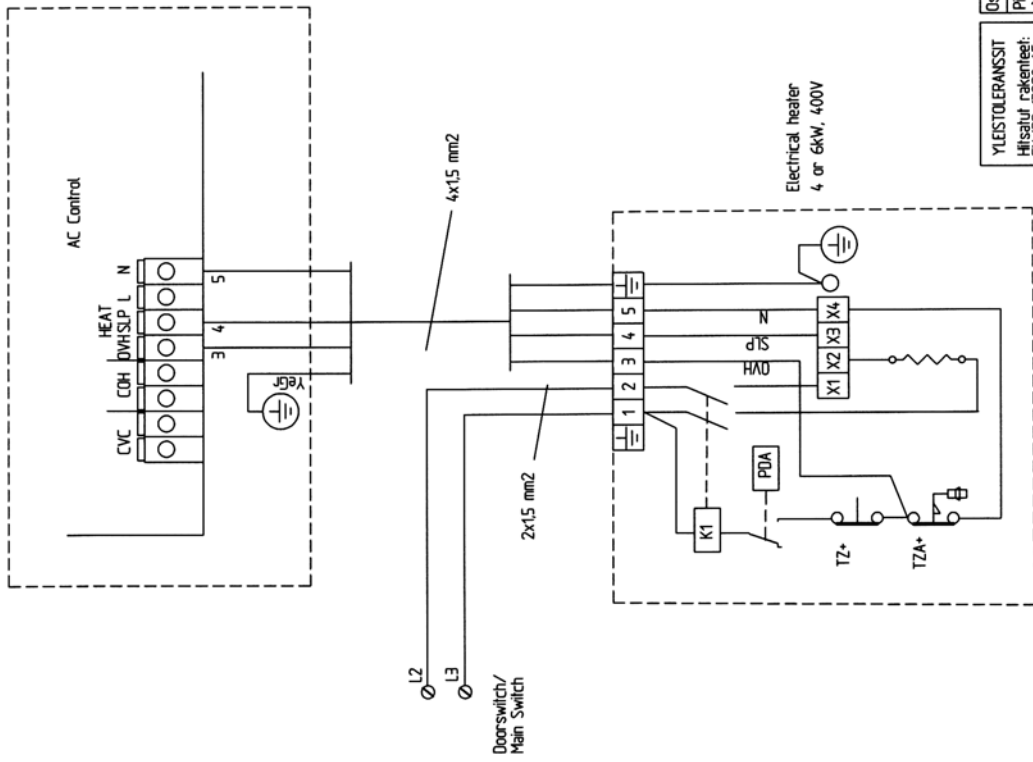

YLEISTOLERANSIT  
 Hitsatukäyttö: EN ISO 19720-AE  
 Käyttö: ISO 2768-mK

Osa	Kpl	Osa nimitys	Valmistaja	File	Suhde
Piiri MW		Tark	Pvm		05.11.2007
ACE and DCE - MODELS			Nimitys		Paino kg
			Connections for 4 or 6kW Electrical heater		Muutos A
			Piiir no		Lehti



Hyy

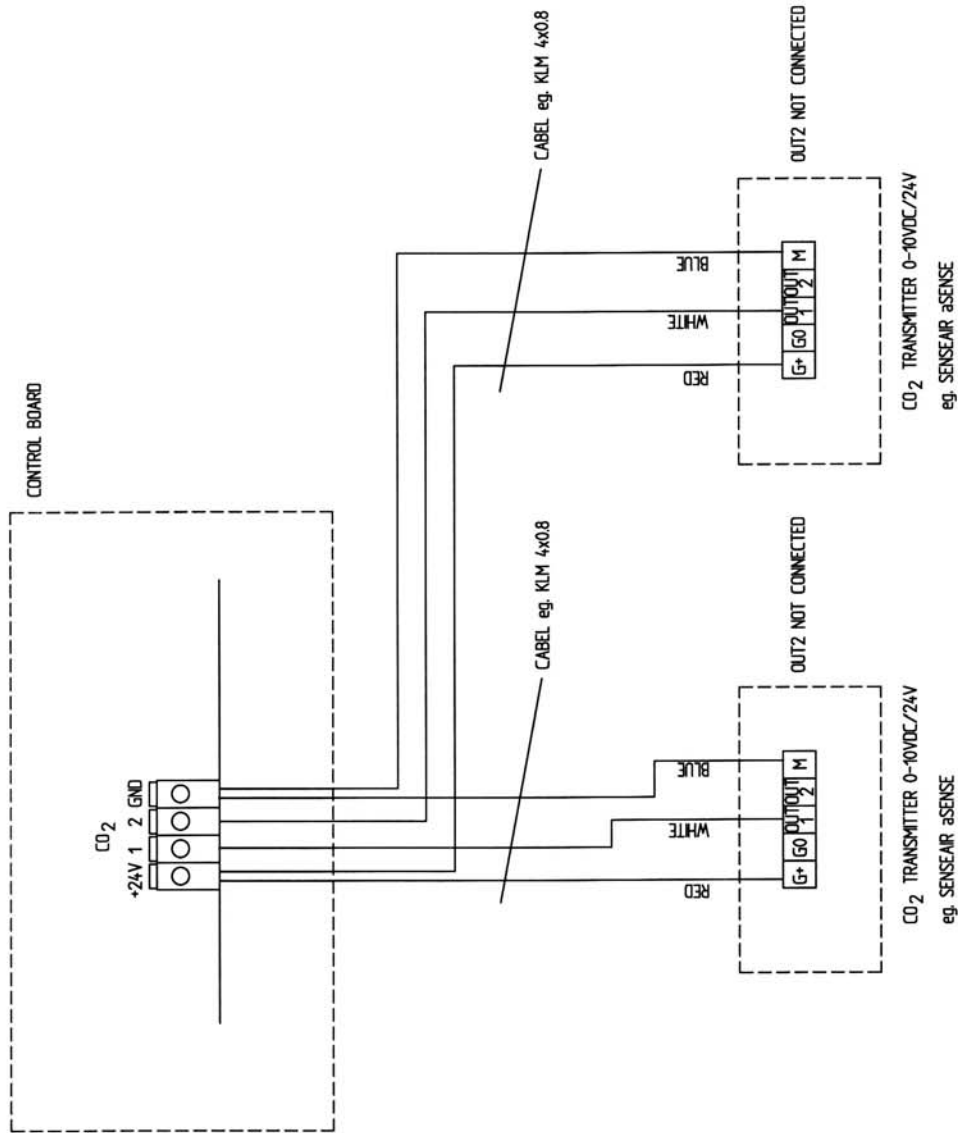

MAX. 2pcs. OF CO2 TRANSMITTERS!  
 CO2 TRANSMITTERS SHOULD BE INSTALLED ON THE WALL  
 THE INSTALLATION HEIGHT IS FREE.

YLEISTOLERANSIT		Osa	Kpl	Osan	nimitys	Valmistaja	Valmistus	Suhte
Hissatut rakenteet: EN ISO 15920-AE		Piiri	Tark	Hyv	File	Pvm	2002-10-17	11
Konesigatut osat: ISO 2768-mK		TOM/NEF			u			
		ALL AC AND DC -MODELS			Nimitys	CO2 TRANSMITTER CONNECTION		
		ENERVENT OY AB P.O. BOX 100 FIN-00010 HELSINKI TEL: +358 9 25110000 FAX: +358 9 25110001			Paino	kg		
		Hyv			Piiri no	ACDC 20020731		
					Muutos	A		
					Lehti			

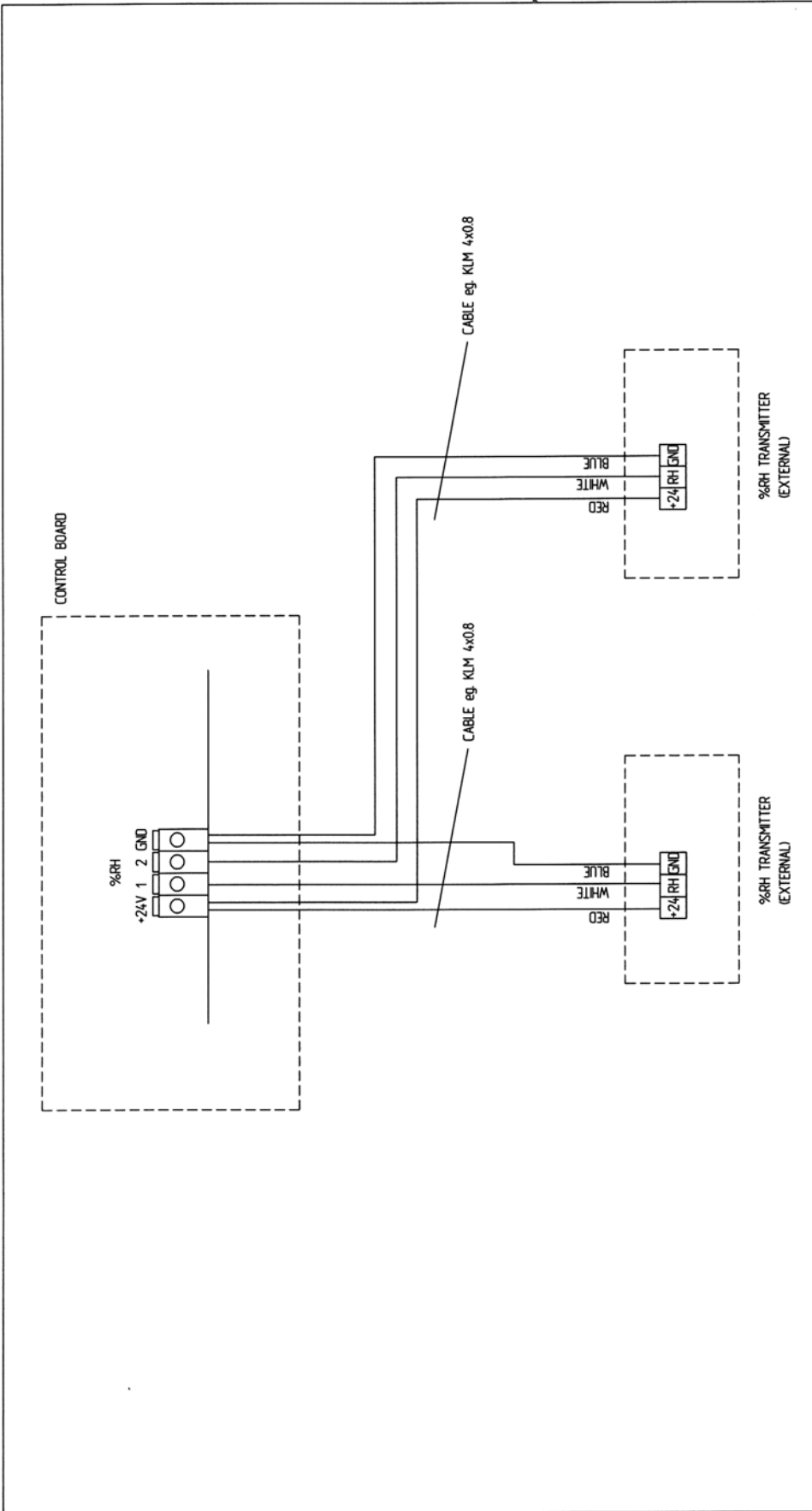

MAX. 2pcs. OF %RH TRANSMITTERS  
 THE TRANSMITTER SHOULD BE INSTALLED ON THE WALL FAREST AWAY FROM THE SHOWER, AT A HEIGHT OF ABOUT 1/3 FROM THE CEILING

YLEISTOLERANSSIT Hissatut rakenteitt: EN ISO 19920-AE Konsistensit, osat: ISO 2768-mk		Osia	Kpl	Osan nimitys	Valmistie	Suhde
Piiri	Tark	Hyv	File	Pvm	2005-10-17	t1
ALL AC AND DC -MODELS		Nimitys		%RH TRANSMITTER CONNECTION		Paino kg
EMERVENT OY AB Puhelin: 010 305 6000 Faksi: 010 305 6001 www.emervent.fi		Pii- no		ACDC 20020801		Muutos
Hyv						A
						Lehti

## 16.2 COH AND CVC INDICATION

### General

The automation mechanically controls the fan speeds if a 50-230 VAC control current has been connected to the COH or CVC connector on the control card.

### COH, indicates the running of the range hood

Wiring alternative 1. Indication directly from the motor of the range hood

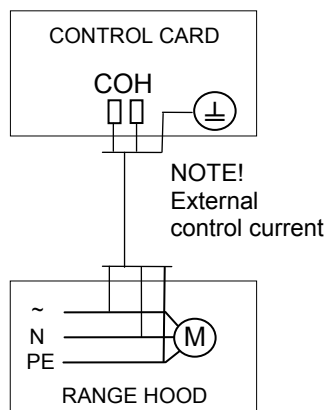

Wiring alternative 2. Indication with pressure-difference switch from the range hood

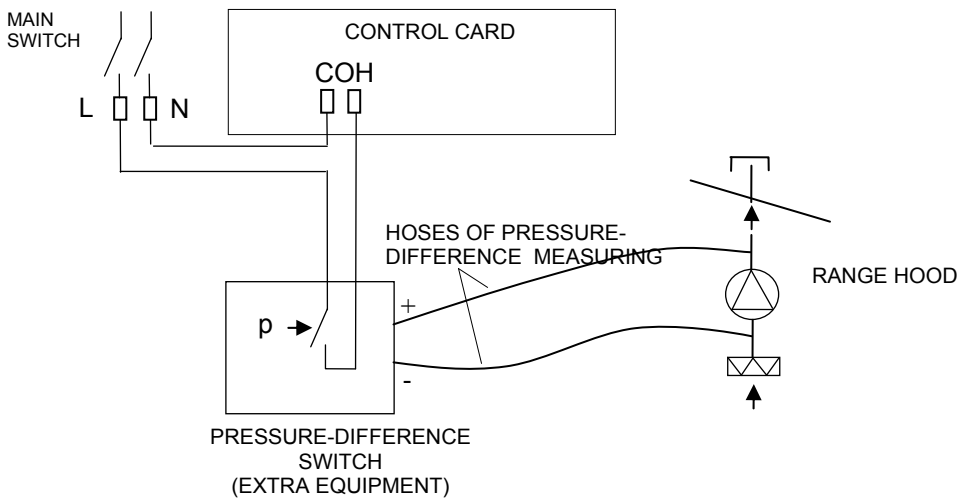



Wiring alternative 3. Indication with the micro switch of the range hood

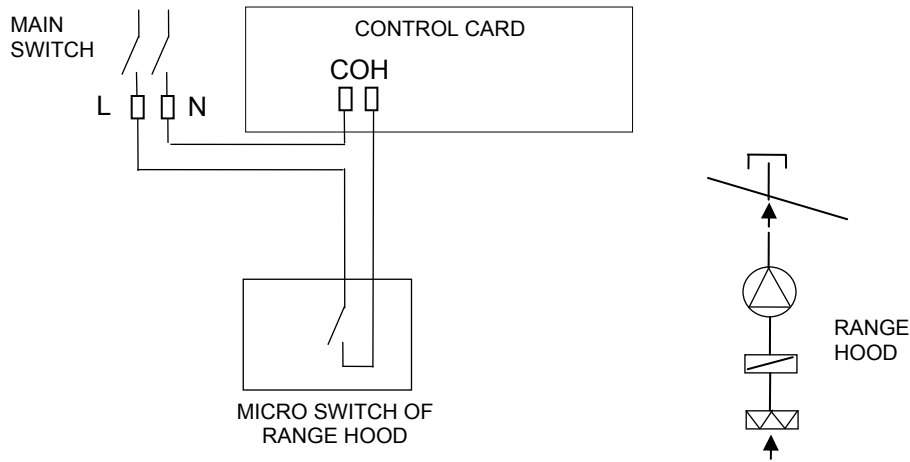

**CVC, indicates the running of the central vacuum cleaner**

Wiring alternative 1. Indication directly from the motor of the central vacuum cleaner

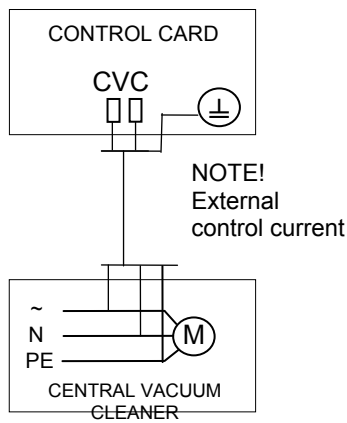

Wiring alternative 2. Indication with pressure-difference switch from the vacuum cleaner

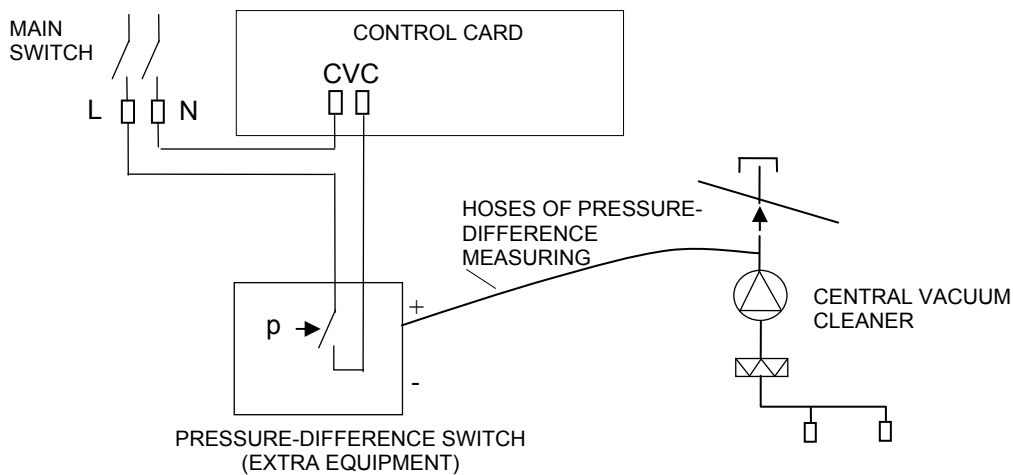

## 16.3 OUTER CABLING OF THE VENTILATION UNIT CONTROL

### ACE automation

Code	Explanation	Delivered	Current	Cabel example
OP	Control panel, max 4 pcs	1 pcs standard	RS485 led	KLM 4x0.8
TE20	Room temperature sensor	Included in OP	max 2 V	-
%RH	Humidity transmitter, max 2 pcs	Extra equipment	0-10 V / 24 V	KLM 4x0.8
CO <sub>2</sub>	Carbon dioxide transmitter, max 2 pcs	Extra equipment	0-10 V / 24 V	KLM 4x0.8
HS	Manual push switch for over pressure control or extended time	Extra equipment	max. 24 V	KLM 2x0.8
COH	Range hood, operational condition	Needs cabling	50-230 V	MMJ 3x1.5s
CVC	Central vacuum cleaner, operational condition	Needs cabling	50-230 V	MMJ 3x1.5s
FV01	Outside air damper, damper motor	Extra equipment	230 V	MMJ 3x1.5s
FV02	Waste air damper, damper motor	Extra equipment	230 V	MMJ 3x1.5s
PDE10	Pressure transmitter of supply air duct	Extra equipment	0-10 V / 24 V	KLM 4x0.8
PDE30	Pressure transmitter of exhaust air duct	Extra equipment	0-10 V / 24 V	KLM 4x0.8
PU50	Water pump (cooling)	Extra equipment	230 V	MMJ 3x1.5s
SV50	Control valve for cooling water	Extra equipment	-	-
TL50	Regulator for the cooling water control valve	Extra equipment	0-10 V / 24 V	KLM 4x0.8
CW	Cooler cw (water), for intstallation in duct	Extra equipment	-	-
CX	Cooler dx (evaporator), for installation in duct	Extra equipment	-	-
TE10	Supply air temperature sensor for cooling, duct	Extra equipment	max. 2 V	KLM 2x0.8

The control panel of all models is delivered uninstalled. The class IP20 control panel must be installed in a dry facility.

The low current cables must absolutely be kept apart from the high current cables!

## **ACW automation**

Code	Explanation	Delivered	Current	Cabel example
OP	Control panel, max 4 pcs	1 pcs standard	RS485 led	KLM 4x0.8
TE20	Room temperature sensor	Included in OP	max 2 V	-
%RH	Humidity transmitter, max 2 pcs	Extra equipment	0-10 V / 24 V	KLM 4x0.8
CO <sub>2</sub>	Carbon dioxide transmitter, max 2 pcs	Extra equipment	0-10 V / 24 V	KLM 4x0.8
HS	Manual push switch for over pressure control or extended time	Extra equipment	max. 24 V	KLM 2x0.8
COH	Range hood, operational condition	Needs cabling	50-230 V	MMJ 3x1.5s
CVC	Central vacuum cleaner, operational condition	Needs cabling	50-230 V	MMJ 3x1.5s
FV01	Outside air damper, damper motor	Extra equipment	230 V	MMJ 3x1.5s
FV02	Waste air damper, damper motor	Extra equipment	230 V	MMJ 3x1.5s
PDE10	Pressure transmitter of supply air duct	Extra equipment	0-10 V / 24 V	KLM 4x0.8
PDE30	Pressure transmitter of exhaust air duct	Extra equipment	0-10 V / 24 V	KLM 4x0.8
HW	Waterheater for installation in duct	Standard equipment	-	-
PU45	Water heater pump	Extra equipment	230 V	MMJ 3x1.5s
SV45	Control valve for heating water	Standard equipment	-	-
TL45	Regulator for the heating water control valve	Standard equipment	3-point / 24 V	KLM 4x0.8
TE45	Heating return water temperature sensor	Standard equipment	max 2 V	KLM 2x0.8
TE10	Supply air temperature sensor, for installation in duct	Standard equipment	max 2 V	KLM 2x0.8
PU50	Water cooler pump	Extra equipment	230 V	MMJ 3x1.5s
SV50	Control valve for cooling water	Extra equipment	-	-
TL50	Regulator for the cooling water control valve	Extra equipment	0-10 V / 24 V	KLM 4x0.8
CW	Cooler cw (water), for intstallation in duct	Extra equipment	-	-
CX	Cooler dx (evaporator), for installation in duct	Extra equipment	-	-

The control panel of all models is delivered uninstalled. The class IP20 control panel must be installed in a dry facility.

The low current cables must absolutely be kept apart from the high current cables!

## 17. FAULT / CORRECTION GUIDE

### INCOMING AIR TOO COLD

#### *Reason*

- \* The rotor switch is in position 0
- \* Belt of the heat exchanger broken
- \* Belt greasy, causing slippage
- \* The exhaust fan has stopped
- \* The exhaust air filter is blocked
- \* Exhaust air vents settings incorrect
- \* Heat insulation of ducts inadequate

#### *Action*

- ☛ Switch to position 1
- ☛ Replace the belt
- ☛ Contact a service man
- ☛ Contact a service man
- ☛ Change the exhaust air filter
- ☛ Contact a service man
- ☛ Check the insulation thickness of the supply and exhaust air ducts and add insulation if needed.

### AIR FLOW BECOMES SMALLER

#### *Reason*

- \* Filters are blocked
- \* Speed selector switch of the fans has been turned down
- \* Blockage in the fresh air grille
- \* Fan wings dirty

#### *Action*

- ☛ Change the filters
- ☛ Select higher speed
- ☛ Clean the outer grille
- ☛ Clean the fans

### OPERATING SOUND LEVEL INCREASED

#### *Reason*

- \* Filters blocked
- \* Outer grilles are blocked
- \* Fan bearings faulty
- \* Problem with gear/motor of the heat exchanger
- \* Fan wings dirty

#### *Action*

- ☛ Change the filters
- ☛ Clean the outer grille
- ☛ Change bearings / contact service
- ☛ Contact a service man
- ☛ Clean the fans

**Note! Also read “Explanation of the lights on the control panel”, page 28.**

## 18. TECHNICAL INFORMATION

Dimensions											
Height	720 mm										
Width	1510 + 100 mm										
Depth	707 mm										
Current	ACW-models: 230 V / 50 Hz, 1-phase, fuse 10 A quick ACE-models: 400 V / 50 Hz, 3-phase, fuse 3x16 A quick										
Control card fuses	F1 T63mA glass tube 5x20 F2 T6,3A glass tube 5x20										
Fans Exhaust air	All models Rating 560 W max. Current 2,5 A Heat protection										
Supply air	Rating 560 W max. Current 2,5 A Heat protection										
Heat exchanger motor	Rating 25 W 0,09 A Heat protection										
Duct size	All models Ø 250 mm										
Weight	130 kg										
<p>Sound level</p> <p>Sound levels from the unit in a room where it is installed. Voice absorption of 10 m<sup>2</sup>.</p> <table style="width: 100%; border-collapse: collapse;"> <thead> <tr> <th style="text-align: left;">Fan speed</th> <th style="text-align: left;">Sound level</th> </tr> </thead> <tbody> <tr> <td>Position 2</td> <td>31 dB (A)</td> </tr> <tr> <td>Position 4</td> <td>39 dB (A)</td> </tr> <tr> <td>Position 6</td> <td>45 dB (A)</td> </tr> <tr> <td>Position 8</td> <td>51 dB (A)</td> </tr> </tbody> </table>		Fan speed	Sound level	Position 2	31 dB (A)	Position 4	39 dB (A)	Position 6	45 dB (A)	Position 8	51 dB (A)
Fan speed	Sound level										
Position 2	31 dB (A)										
Position 4	39 dB (A)										
Position 6	45 dB (A)										
Position 8	51 dB (A)										