

PINGVIN AC

PLANNING, INSTALLATION AND
OPERATION INSTRUCTIONS



Kipinätie 1, 06150 BORGÅ FINLAND
Phone +358 207 528 800, fax +358 207 528 844
www.enervent.fi

MODEL

Before you begin reading, confirm the model of your appliance.
These instructions cover the following models:

Pingvin ACE
Pingvin ACE KS

Pingvin ACW
Pingvin ACW KS

EXPLANATION OF THE MARKS AND NUMBERS

- AC Alternating current fans 185 W, 230 V.
- E Electrical heating coil 400 W (built-in), with over heating protection, built-in temperature sensor and regulator.
- W Water heater (Ø 160 mm for installation in duct), freeze protection, 2-way valve, valve actuator, duct temperature sensor and regulator.
- KS Uninstalled control panel (needs cabling KLM 4 x 0.8). N.B! The KS-models have not got an attached control panel. The KS-models can be installed in humid premises, IP44.

On all models the ducting connections are Ø 160 mm.

ENG

INTRODUCTION

All Pingvin ventilation equipment has been designed for all year round use. In Finland the Enervent appliances have been installed in small premises and detached houses for over 20 years. The popularity of the appliances is increasing year by year. Using knowledge gained over the years, it has been possible to make the Pingvin range more and more user-friendly.

The Pingvin AC range is the result of long-term product development. It is very versatile and variable.

With the help of this manual it is possible to install a appliance with basic functions yourself. We recommend that installation of ventilation units with special functions and extra equipment be carried out by a qualified electrician.

We recommend that a qualified ventilation engineer performs the installation work.

Before any maintenance of the appliance is carried out, please read the warning on page 5!



GUARANTEE

Enervent Oy Ab admits a two (2) year product guarantee on the Pingvin range. The guarantee covers the repair work with the necessary spare parts. Repair service will be carried out at the factory premises in Porvoo, Finland or as agreed.

The guarantee is not valid if the unit has been incorrectly installed, poorly maintained or mechanical damage has resulted from improper use. This guarantee does not compensate for losses indirectly caused by the use of the appliance, troubleshooting, installation after the repair or transportation.

Retain the receipt as proof of purchase, and for the start date of the guarantee period.

TABLE OF CONTENTS

MODEL	page	2
INTRODUCTION		3
GUARANTEE		3
TABLE OF CONTENTS		4
WARNING		5
1. OPERATING PRINCIPAL		5
2. INSTALLATION PARTS		6
3. PLANNING OF THE DUCT SYSTEM		8
4. EXTRACT AIR CLASSIFICATION OF LIVING AREAS		10
5. PHASES OF INSTALLATION		11
6. HEAT INSULATION OF AIR DUCTS		12
7. DESCRIPTION OF FUNCTIONS		13
7.1 Controlling running and fan speeds		13
7.2 Regulating fan speeds		14
7.3 Using the heat recovery in the summer time		15
7.4 Defrosting of the heat recovery wheel		15
7.5 Heat recovery efficiency		15
7.6 Regulating temperatures		15
7.7 Over heating protection of the electrical heating coil		16
7.8 Freeze protection of the water heater		16
7.9 Damper motor regulation		17
7.10 Regulating the proportion of supply and exhaust air		17
7.11 Maintenance- och fault alarms		17
8. FUNCTIONS OF THE CONTROL PANEL		18
8.1 Normal state		18
8.2 Main menu		19
8.3 Fan speeds		20
8.4 Temperatures		21
8.5 CO ₂ control		22
8.6 %RH control		23
8.7 Pressure control		24
8.8 Settings		25
8.9 Service menu		26
8.10 Setting the weekly timer		28
8.11 Explanation of the lights on the control panel		29
9. AIR FLOW REFERENCE VALUES		30
10. KITCHEN VENTILATION		30
11. TO BE OBSERVED DURING OPERATION!		31
12. HEAT RECOVERY EFFICIENCY		31
13. MAINTENANCE		32
14. BELT INSPECTION AND REPLACEMENT		33
15. CHARACTERISTICS		35
16. WIRING DIAGRAMS		36
16.1 Electrical wiring diagrams		36
16.2 COH and CVC indication		42
16.3 Outer cabling of the control		44
17. FAULT / CORRECTION GUIDE		46
18. TECHNICAL DATA		47

WARNING

Switch off the power supply to the appliance before you open the service hatch! Even though the main power switch is in the 0 position, parts of the unit remain live. There are no user-serviceable parts behind the control panel, contact a service technician for service and repairs of this part of the unit.

Clarify the cause of the fault before restarting the unit!

1. OPERATING PRINCIPLE

The Pingvin ventilation unit is based on regenerative heat recovery. This is achieved with a rotating heat exchanger through the halves of which incoming air and exhaust air flow in opposite directions. Aluminium foils of the heat exchanger transfer heat from the exhaust air to the supply air.

A characteristic of the regenerative heat exchanger is its high rate of heat recovery.

The heating rate of the supply air varies from 75 % to 85 %, depending on the proportion of supply air and exhaust air (the heat from the supply air fan is taken into count). Thanks to its high heat recovery, Pingvin saves heating energy at the same time as it takes care of a good indoor air quality; therefore it repays itself in a relatively short time.

2. INSTALLATION PARTS

A. STANDARD PARTS

- Pingvin AC ventilation unit (delivered with EU5 plain filters)
- Rear attachment wall bracket
- Water heater (Ø160 mm for installation in duct), control valve, valve actuator, duct temperature sensor and a water heater freeze protection sensor (ACW-models)

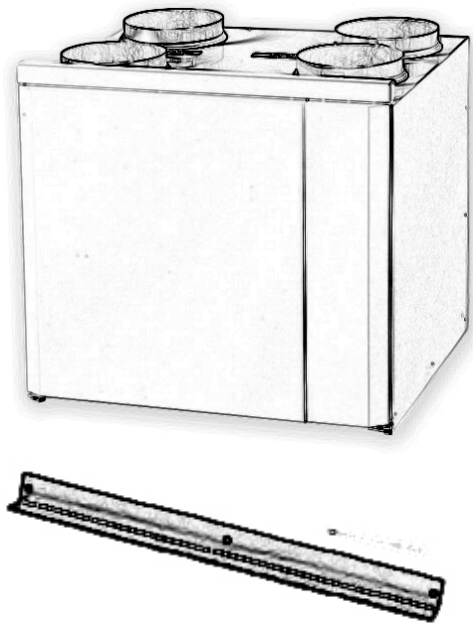

Pingvin AC and the wall bracket

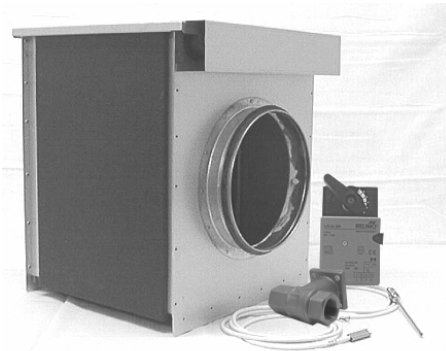

Water heater, control valve, valve actuator, duct temperature sensor and freeze protection sensor

B. EXTRA EQUIPMENT

- Uninstalled control panel (max 1+4 panels can be attached to the automation)
- CO₂ carbon dioxide transmitter (max 2 transmitters can be attached to the automation)
- %RH humidity transmitter (max 2 transmitters can be attached to the automation)
- Pressure difference transmitter for the exhaust air filter (filter guard)
- Pressure difference transmitter for the ducts (constant pressure)
- Push button for over pressure control (for use in home mode)
- Push button for extend time control (for use in office mode)
- Silencers for the ducts
- Outside air and waste air dampers
- Damper motors (with spring return)
- Micro filter EU7 (built-in or duct installed)
- CW-cooling coil, (Ø160 mm for installation in duct), control valve, valve actuator, duct temperature sensor
- Evaporator (Ø160 mm for installation in duct)



%RH humidity transmitter



Control panel



CO₂ carbon dioxide transmitter

C. ADDITIONAL EQUIPMENT

- Filter EU5
- Microfilter EU7 (built-in or duct installed)

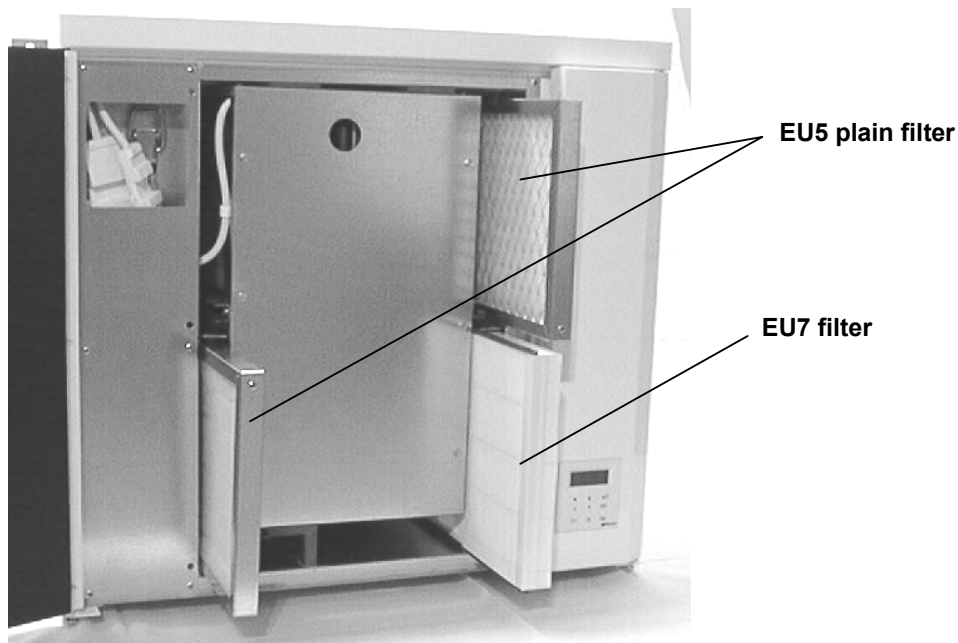

3. PLANNING OF THE DUCT SYSTEM

It is recommended that the task of dimensioning the duct system is given to a professional installer.

The ducts must be large enough, min. Ø 100 mm, to allow an sufficiently low air speed. In particular the outside feed and the waste air ducts need to be wide. The size of the outside air duct, waste air duct and the outside grille must be Ø 160 mm. Do not fit an insect net behind the grille.

Use only type approved materials, as galvanised spiral-weld or plastic pipe, for the duct system. Valves which are suitable for mechanical ventilation must be used. Valves with a diameter of 100 mm or larger are to be used for supply and exhaust air.

The outside air should be taken, if possible from the north side of the building or from a shady place where temperature variations are moderately small.

The waste air should be led out about 90 cm above the roof saddle. Use insulated factory made fittings. A cover must be installed on the end of the waste air duct to prevent rain water from entering the duct system.

To enable duct cleaning, a sufficient number of control hatches should be placed in the duct system. The control hatch locations could be marked for example on the roof trusses to make finding them easier.

The extract air valves are placed in the following premises: Toilet, kitchen, washroom, bathroom, clothing storage room, cleaning cupboard and utility room.

The supply air valves are placed in the following premises: bedroom, living room, separate dining recess, hobby room, dressing room and sauna. We recommend that a supply air valve is installed in the innermost corner of the sauna. The air flow from the valve should be directed above the stove.

The air from a room with supply air is supposed to flow through chinks of the doors or “free flow” door grilles to areas with exhaust air. Normally a 20 mm chink of the door is enough besides in the sauna where a 100 mm chink is needed. Additional supply air can be ducted directly to wood-burning fireplaces (in the sauna) from the outside. The duct must be closable.

Garages or workshops must not be connected into the ventilation equipment of the house; they should have their own extractor system or independent heat recovery unit.

The cooker extractor hood should not be connected into the house ventilation system. (Excess steam and grease will cause blockage of the heat exchanger).

A fan assisted drying cabinet can be connected indirectly to the extract valve (drying cabinet - valve attachment) which allows air from both the room and the cabinet to extract from the same valve. The volume through the extract air valve has to be at least 12 l/s.

Silencers. A hard silencer 09 is recommended for the extract duct, a silencer 09 or 06 is recommended for the supply air duct.

The distances between waste air and fresh air openings. Usually fresh air is taken from a north facing wall and the waste air is led out from the roof. The diagram shows how to determine the distance between the outside feed into the house and the waste from the house.

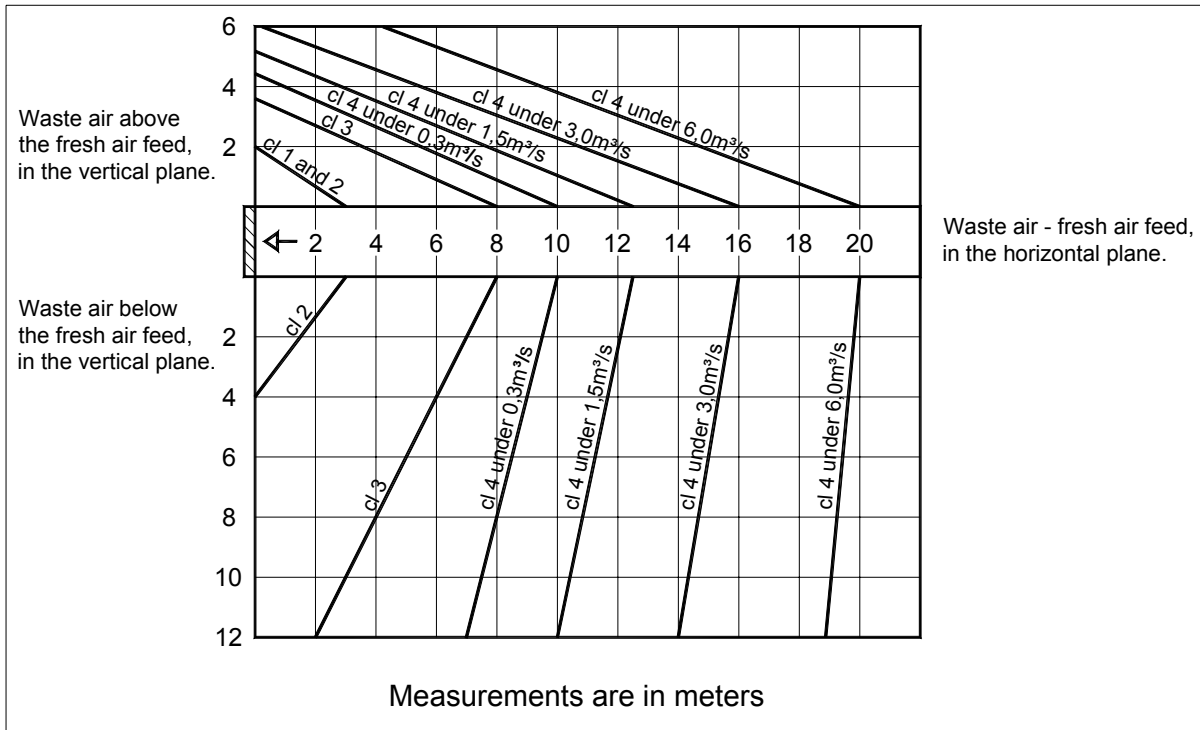

Other methods are acceptable, so long as they fall within the guidelines laid out by the Ministry of the Environment's code of building regulations (D2: Finland 2003, extract shown below), or in accordance with your local directives and regulations governing indoor climate and building ventilation.

4. EXTRACT AIR CLASSIFICATION OF LIVING AREAS

The leading of waste air from a building is based on the following, extract air classification

- Class 1** Extract air which contains few impurities. The impurities are mainly from people or structures. Air is suitable for return air and transfer air.
- Class 2** Extract air which contains some impurities. The air is not used as return air of other premises but can be lead for example to the toilet and washing room as transfer air.
- Class 3** Extract air from premises where high humidity, processes, chemicals and smells essentially lower the quality of exhaust air. The air is not used as return air or transfer air.
- Class 4** Extract air which contains ill-smelling or unhealthy impurities considerably more than the acceptable contents of the indoor air. The air is not used as return air or transfer air.

Examples of extract air class of living areas

- Class 1** Office rooms and small adjoining storage spaces, customer service and teaching premises, meeting and business premises which are non-odorous.
- Class 2** Living rooms, dining recesses, coffee kitchens, shops, warehouses of office buildings, dressing rooms and restaurant premises where smoking is forbidden.
- Class 3** Toilets, washing rooms, saunas, apartment kitchens, distribution and teaching kitchens, copying premises of drawings.
- Class 4** Professionally used fume cupboards, grilles and target exhaust air from kitchens, car garages and driving tunnels, handling rooms of paints and solvent, dirty wash laundries, store rooms of waste food, chemical laboratories, smoking rooms, hotel and restaurant premises where smoking is permitted.

(Finland's building regulations D2 2003)

5. PHASES OF INSTALLATION

The unit should be installed on the wall in a warm or half warm room (over +5 °C). The location can be for example a scullery or utility room, however, not the garage (a separate fire area). If the device is used for the ventilation of a pool area, action should be taken to drain off possible condensation water. In the bottom of the unit is a drain connection (1/4" inner thread). The connection is delivered plugged.

Phases of installation:

- A. Mark and cut the holes into the ceiling.
- B. Draw the ducts through the holes to the required height. The gaps between duct and steam barrier are then sealed, with for instance ventilation tape.
- C. Install the rear attachment bracket directly to the wall at required height, or onto an insulation board to reduce the transfer of machine noise or vibration.
- D. Place the unit onto the lower bracket and fasten to the wall with the two top brackets. Attach the lower bracket with plate screws to the bottom of the unit.
- E. Connect the ducts to the tubes on top of the unit. It is recommended that silencers be installed to the exhaust air and supply air ducts. Silencers, see page 7.
- F. If the unit's condensation drain is to be used, connect a pipe between the drain outlet and the nearest floor drain or water trap of a sink. Connecting the unit directly into the sewage system is not allowed.

N.B.! To reduce the weight of the unit remove the rotor before mounting on the wall.

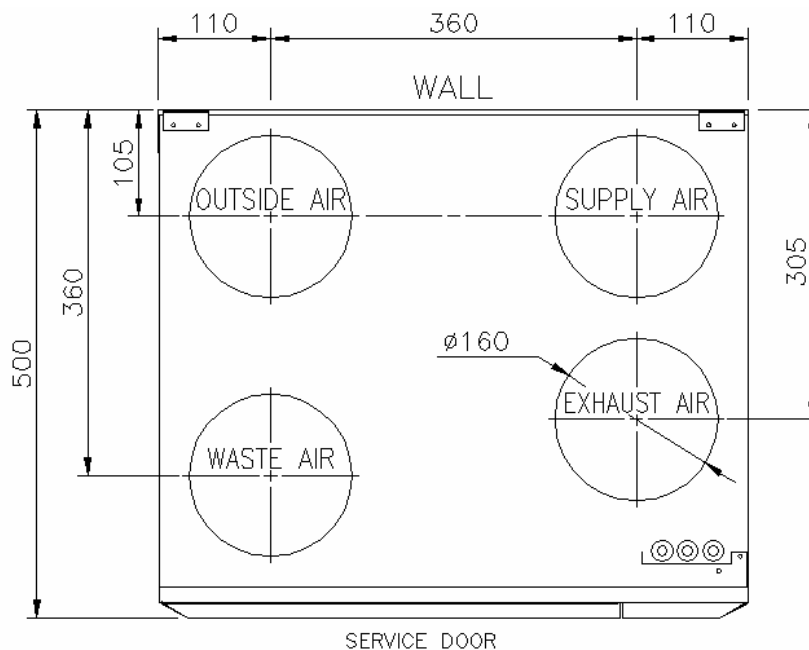

All Pingvin models

6. HEAT INSULATION OF THE DUCTING SYSTEM

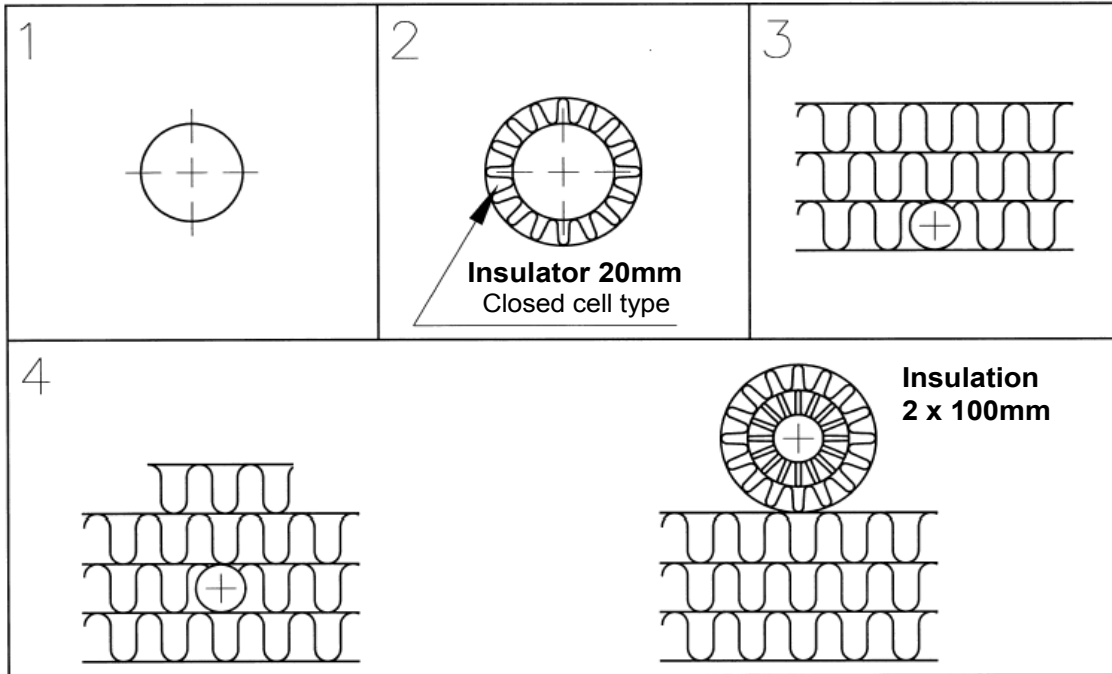

The figure shows different examples of ductwork insulation.

1. Extract air duct in warm state (indoor, no insulation).
2. Waste air duct and fresh air duct in warm state (indoor).
Insulation, for example Armaflex™
3. Extract air duct on attic under the insulation but above the steam barrier.
4. All air ducts on a cold attic. The waste or fresh air ducts must not be installed immediately above the steam barrier; there should be a mineral wool insulating layer of at least 100 mm between them.

7. DESCRIPTION OF FUNCTIONS

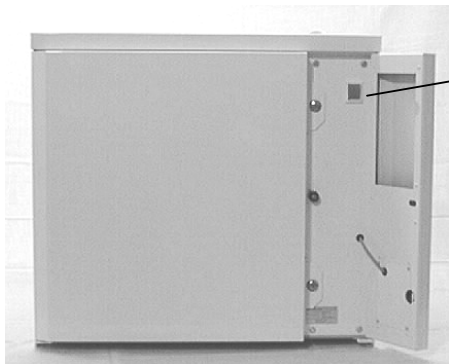

Pingvin AC main switch

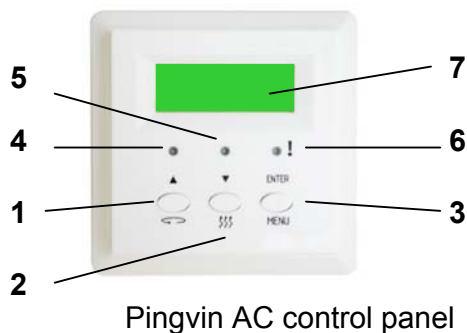

Pingvin AC control panel

1. Heat recovery button / scroll upwards / increase numeric value
2. Heater control button / scroll downwards / decrease numeric value
3. Menu / enter button, access to main menu , verify changes
4. HRW indicator light
5. Heater control indicator light
6. Maintenance / fault indicator light
7. Display

7.1 CONTROLLING RUNNING AND FAN SPEEDS

When the unit is turned on, the extract air fan starts first and then the heat recovery exchanger. About one minute later the supply air fan starts. The unit always starts on minimum effect. After this the fan speed is regulated from the control panel, by the air quality sensors or by an outer electrical signal i.e. from the range hood or central vacuum cleaner.

The fan speeds can also be regulated with a weekly timer, so that the fan speeds are at a specific level at a specific time. This way the fans can be set to run on a lower speed i.e. when the apartment is empty. There are eight (8) speeds for each fan to choose from.

It is possible to turn off the fans for a certain time using the weekly timer, if the automation is set on "office mode". In that case there must be dampers (extra equipment) in the outside air and waste air ducts that stop cold air from flowing inside. In spite of the weekly timer program, the fans can be started again for a certain time by pushing an extended time button. In the "office mode" the outer electrical controls are not possible.

The following circumstances affect the fan speeds:

- Boosting, over pressure control and extended time control.
- The fan speed is automatically set to speed 1 if the supply air is too cold.
- If there is a problem with the heat exchanger, the supply air fan automatically stops and the exhaust air fan is set on speed 1.
- Restrictive guidance from the range hood or central vacuum cleaner (constant pressure).
- Summer night cooling

The following is valid according to model:

- ACE-models: The fans stop if the over heating protection goes off (setting off is manual).
- ACW-models: The fans stop if the freeze protection goes off.

7.2 REGULATING FAN SPEEDS

Carbon dioxide and humidity control

The fans are controlled with the help of the information gathered by the CO₂ and RH% sensors in the ventilated premises. Two (2) carbon dioxide and two (2) humidity sensors (extra equipments) can be attached to the automation.

The goal is to keep the CO₂ and/or the RH% level beneath the preset value. If no outer humidity sensor is attached, the fan speeds are controlled by the one built-in humidity sensor in the ventilation unit. This function must be activated in the RH% menu on the control panel.

The maximum fan speeds of the air quality control are programmed in to the control panel.

Constant pressure control

The goal is to keep the pressure level constant in the apartment, despite starting the range hood or central vacuum cleaner. The benefit of keeping the pressure constant is i.e. that the fireplace burns better.

The constant pressure control requires a separate electrical signal from the range hood and the central vacuum cleaner. The constant pressure control can be deactivated from the control panel. This function is possible only in home mode.

Over pressure control

This function allows us to create a momentary over pressure in the apartment, which makes lighting the fire easier. The over pressure can be activated from the control panel or from a separate push button (extra equipment). The duration of the over pressure and the fan speeds during it, is programmed in to the control panel. The functions can be deactivated from the control panel. Over pressure control is possible only in home mode.

Boosting

Boosting is activated from the control panel. Boosting increases the speed of both fans for a given time, according to the values (efficiency and time) set in the control panel.

The boosting function can be deactivated from the control panel. Boosting can be active simultaneously with the constant pressure control and/or the over pressure control. Boosting is possible in both office and home mode.

Extended time control

It is possible to start the unit on so called extended time, after the weekly timer has shut down the ventilation unit in office mode. The duration of the extended time is set on the control panel. The extended time control is activated either from the control panel or from a separate push button (extra equipment). The extended time control can be deactivated from the control panel. This function is possible only in office mode.

Constant pressure

Two pressure-difference transmitters 0-10 V / 24 V (extra equipment) can be attached to the control panel. They measure the pressure in the supply and extract air ducts and the pressure is kept constant by changing the fan speeds if needed.

7.3 USING THE HEAT RECOVERY IN THE SUMMER TIME

Efficiency reduction

The heat recovery can be turned off in the summertime, if the outside air temperature exceed the limit set for HRW SUMMER (possible settings +10 ... +20°C, factory setting +18°C). During the efficiency reduction, the heat recovery wheel stands still. During the stand still the heat recovery wheel rotates for ten (10) seconds every two hours to prevent dust from collecting on the wheel (automatic purging operation).

The recovery wheel also stops automatically if the supply air, extract air or room temperature, depending on chosen function, exceeds the set value with 3°C ($\pm 1^\circ\text{C}$). The following additional clauses have to be fulfilled: the extract air temperature is 3°C ($\pm 1^\circ$) warmer than the outside air and the outside air temperature exceeds the set HRW SUMMER value.

The HRW automatic purging operation is not active in office mode, when the unit is shut down by the weekly timer.

Cool recovery

(! shines green and the HRW-light is lit)

During the efficiency reduction in the summertime the recovery wheel rotates continuously when the outside air temperature is 3°C higher than the extract air temperature. The recovery wheel stops, when the outside air temperature is 1°C higher than the extract air temperature.

7.4 DEFROSTING OF THE HEAT EXCHANGER

The controller instructs the supply air fan to work periodically, based on the temperatures of the extract air and the outside air together with the humidity content of the extractair, to prevent the heat recovery wheel from freezing. When the defrosting is active, the waste air temperature (at sensor TE31) is kept between the set values. The extract air fan works normally when the risc of freezing is over for the recovery wheel. The defrosting can be deactivated from the control panel.

7.5 HEAT EXCHANGER EFFICIENCY

The heat recovery efficiency of the supply air is shown in percent on the control panel.

7.6 TEMPERATURE REGULATION

Constant supply air temperature

The controller regulates the efficiency of the electrical or water heater, based on the information given by the supply air temperature sensor (TE10), in order to keep the supply air temperature at the set value $\pm 1^\circ\text{C}$ (possible settings +15° ... +25°C). In addition there is a possibility of 0-10 V outlet for cooling control.

Constant room temperature

The controller regulates the efficiency of the electrical or water heater, based on the information given by the temperature sensor (TE20) in the control panel, in order to keep the room temperature at the set value $\pm 1^{\circ}\text{C}$ (possible settings $+15^{\circ}\dots+25^{\circ}\text{C}$). If several control panels are attached, the mean value of the results from the panels is counted and used as the current value. If one of the panels is installed in a much warmer or colder space, a temperature correction can be done for its measuring or alternatively its result can be left out totally. The supply air max and min temperature is restricted at the sensor. In addition there is a possibility of 0-10 V outlet for cooling control.

Constant exhaust air temperature

The controller regulates the efficiency of the electrical or water heater, based on the information given by the extract air temperature sensor (TE30), in order to keep the extract air temperature at the set value $\pm 1^{\circ}\text{C}$ (possible settings $+15^{\circ}\dots+25^{\circ}\text{C}$). In addition there is a possibility of 0-10 V outlet for cooling control. The supply air max and min temperature is restricted at the sensor. In addition there is a possibility of 0-10 V outlet for cooling control.

The after heating is programmed to function only if the heat recovery is on and the controller requests heating. The after cooling is on only if the controller requests cooling. The heating and the cooling are never on at the same time. Neither the heating nor the cooling is on if the unit is turned off by the weekly timer in office mode.

Summer night cooling

(! shines green)

During the summer it is possible to lower the room temperature by letting cool air flow inside at night. When using summer night cooling, the real cooling, heat recovery and heating are not active. The fan speeds are controlled as programmed in the preset program. Even if one should have chosen different speeds for the fans, the fans work on normal speed during summer night cooling.

The summer night cooling is automatic. It is active only between 22.00 and 7.00.

7.7 OVER HEATING PROTECTION OF THE ELECTRICAL HEATER (ACE-models)

The thermostat TZ+ controls the temperature of the electrical heater. If the temperature exceeds i.e. $+50^{\circ}\text{C}$ ($\pm 4^{\circ}\text{C}$) the electrical supply to the heater is automatically cut off, but the fans remain on. The electrical supply is automatically restored when the temperature has dropped to $+39^{\circ}\text{C}$ ($\pm 4^{\circ}\text{C}$).

The temperature limiter TZA+ also controls the temperature of the electrical heater. If the temperature exceeds i.e. $+75^{\circ}\text{C}$ ($\pm 4^{\circ}\text{C}$), the over heating protection goes off and the power supply to the heater is cut.

Setting off the over heating protection is manual. When TZA+ goes off it prohibits the heating relay from pulling and stops the fans.

7.8 FREEZE PROTECTION OF THE WATER HEATER (ACW-models)

If the return water temperature drops beneath +10°C while the unit is on, the automation starts opening the control valve. If the return water temperature drops beneath +5°C although the control valve is fully open, the freeze protection goes off and the control stops the fans and gives an alarm.

If a return water temperature sensor is not installed, the fans will not start and an alarm is given.

7.9 DAMPER MOTOR CONTROL

The dampers, FV1 and FV2 (extra equipment), motors M (extra equipment) are controlled side by side. The dampers are open when the fans are on. The damper motors have spring returns and are de-energized when the dampers are closed.

7.10 REGULATING THE PROPORTION OF SUPPLY AIR AND EXHAUST AIR

The exhaust air flow should be at least 10 % greater than the supply air flow. This is performed by accurately measuring the air flow through all of the vents with for example a thermo anemometer and by adjusting them to the correctly calculated values. A correctly balanced system returns a good heat recovery rate and keeps a slight negative pressure in the building. The negative pressure keeps the humidity away from the structures. When an adjustment is made, the filters must be clean and all the valves and outer grilles must be in place. There must not be an insect net over the fresh air grille.

7.11 MAINTENANCE AND FAULT ALARMS

Filters

Every fourth month the ! sign (orange) automatically lits up on the operating panel as a reminder that the filters should be changed.

Heat recovery

The heat recovery wheel alarms if the recovery efficiency considerably decreases due to malfunction (the ! sign flashes red). The supply air fan is turned off and the exhaust air fan is turned to speed 1. When the defrosting of the heat exchanger is active, an alarm is not given.

Temperatures

If the supply air temperature exceeds or falls short of the set action limit the ! sign shines orange.

If the extract air temperature falls short of the set action limit the ! sign shines orange.

If the supply air is too cold, the supply and extract air fans are switched to speed 1.

Electrical heater (The ACE-models)

When the electrical heater temperature limiter (TZA+) goes off, an alarm is given (the ! sign flashes red)

Water heater (the ACW models)

When the freeze protection of the water heater goes off, an alarm is given (the ! sign flashes red)

All alarms are also shown in text on the control panel. When an alarm is given, the control panel goes over to showing it.

8. FUNCTIONS OF THE CONTROL PANEL

8.1 NORMAL STATE

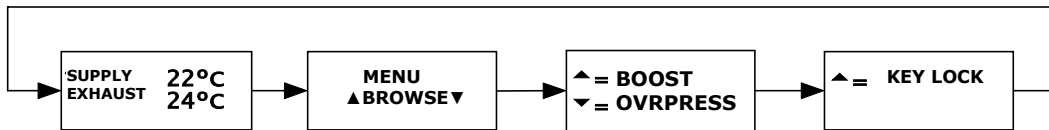

Chart 1. The normal state and the functions available in it at home mode

In normal state a basic display like the one in chart 1. is shown. The basic display contains of two lines which values can be chosen depending on what values one wants to observe, i.e. temperature or recovery efficiency. For more information about the basic display see the Settings-menu / Choose the basic display.

When the menu button is pressed again and again the windows in chart 1 appear one by one. Their functions are:

1. MENU / BROWSE

Entering the main menu is done by pressing up or down in this window. For more information see the item Main menu.

2. BOOSTING / OVERPRESSURE

The boosting function momentarily makes the ventilaiton more effective, which is useful i.e. after sauna or shower. The boosting function is activated and deactivated with the ▲-button. When the boosting function is active, “BOOST” is shown on the lower line on the display. The duration and fan speeds for the boosting is chosen in the Fan speeds-menu.

The unit is equipped with an overpressure function, which i.e. makes it easier to light a fire in the fireplace. Fore more information see the Pressure control-menu. The over pressure is activated by pressing the ▼-button. This function is possible only in home mode. In office mode the overpressure function is replaced with the extended time function. Fore more information see the Fan speeds menu.

3. KEY LOCK

The ▲-button activates the key lock. It might be a good idea to have the keys locked to prevent unintended use. Press menu>menu>menu>▲ to unlock the key lock.

8.2 MAIN MENU

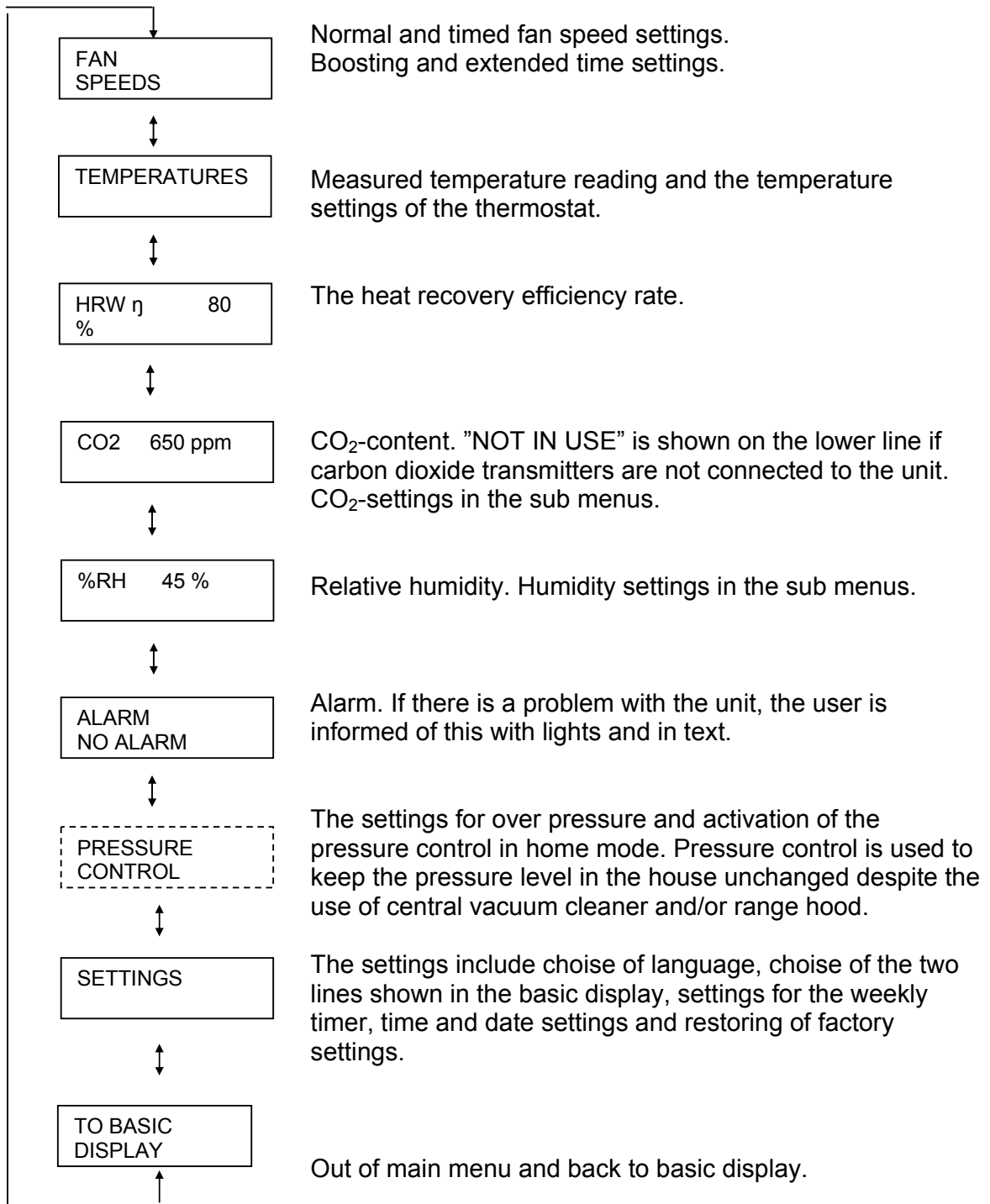

8.3 FAN SPEEDS

The following menu is available for fan speed settings:

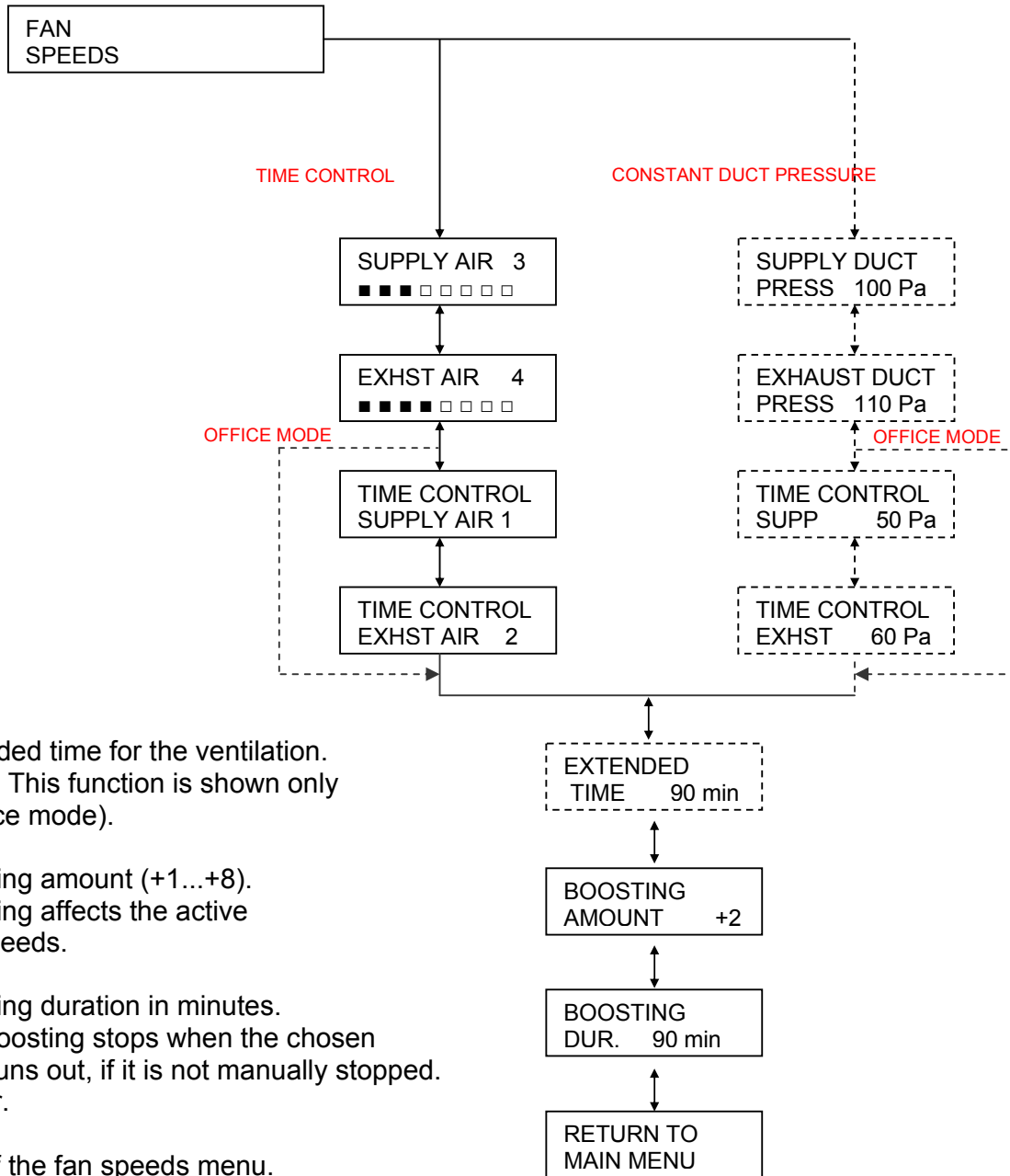

Extended time for the ventilation.
(Note! This function is shown only
in office mode).

Boosting amount (+1...+8).
Boosting affects the active
fan speeds.

Boosting duration in minutes.
The boosting stops when the chosen
time runs out, if it is not manually stopped.
earlier.

Out of the fan speeds menu.

8.4 TEMPERATURES

The following menu is available for fan temperature settings:

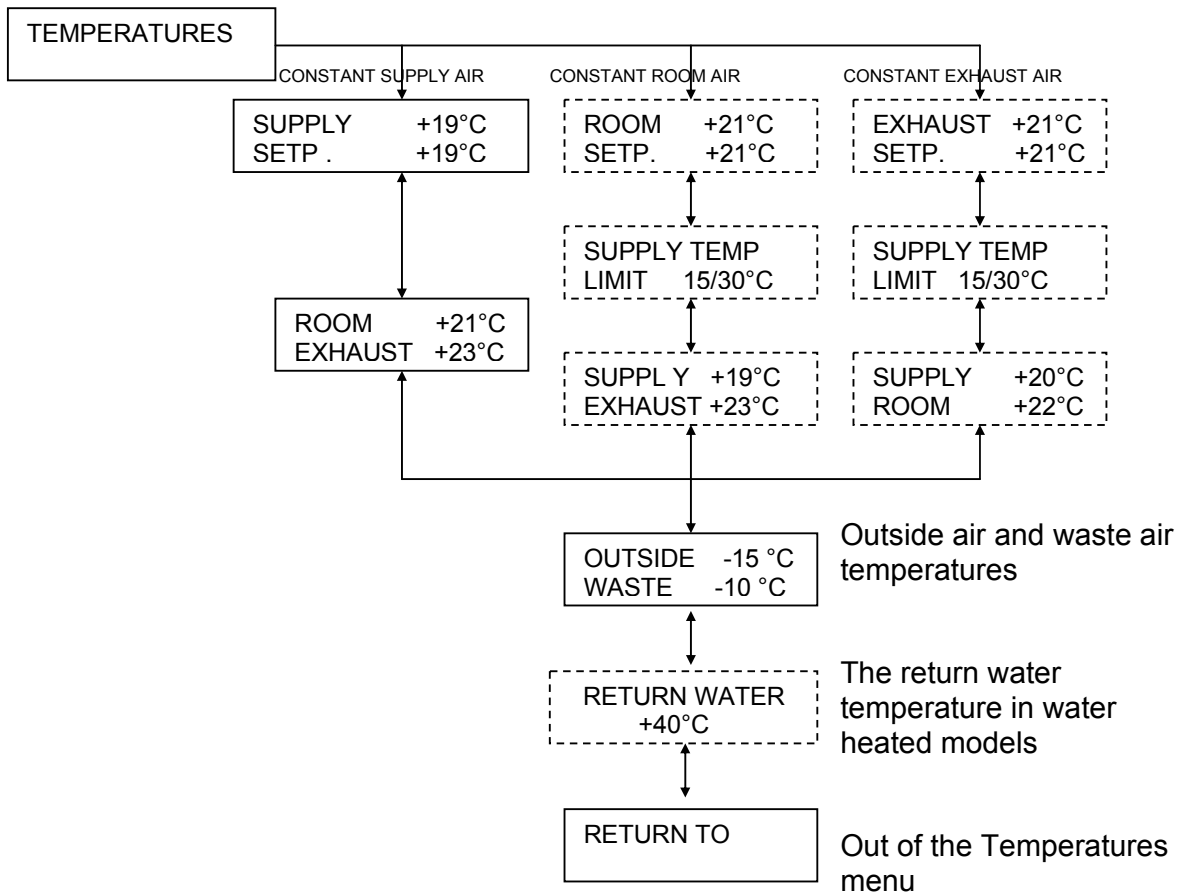

SETP. Desired supply air, room or exhaust air temperature, depending on which temperature regulation mode that is chosen in the maintenance menu

SUPPLY The supply air temperature

ROOM The room temperature

EXTRACT The extract air temperature

SUPPLY TEMP

LIMIT Supply air minimum and maximum temperature limit at constant room or exhaust air settings

8.5 CO₂ CONTROL

The following menu is available for CO₂ control:

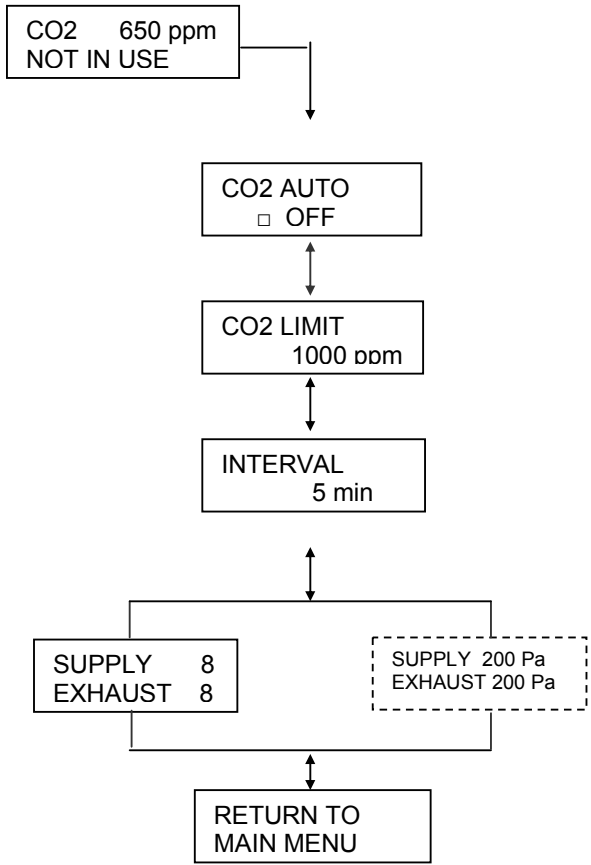

Here the actual CO₂ content of the air is shown. NOT IN USE is shown on the display if CO₂ transmitters have not been installed.

Here the CO₂ control is activated or de-activated. A CO₂ transmitter is needed for the control to work

The CO₂ limit, after which the fans are boosted, is adjusted here.

Here the time frame, for how fast the fan speeds increase with one step, is adjusted

Here the maximum fan speeds or duct pressure for the boosting is adjusted.

Out of the CO₂-menu.

8.6 %RH CONTROL

The following menu is available for %RH control:

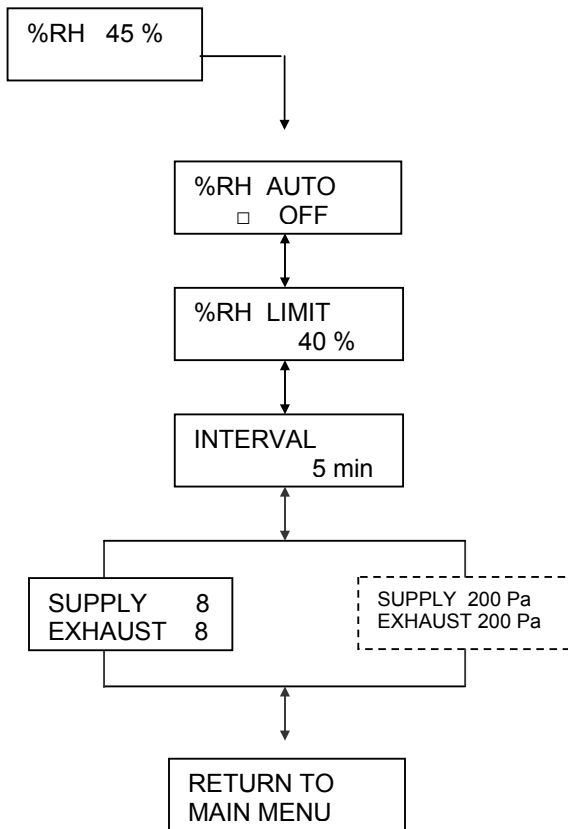

Here the actual relative humidity of the air in the house is shown. If several humidity transmitters have been installed, the highest value is shown.

Here the %RH control is activated or deactivated.

The %RH limit after which the fans are boosted is adjusted here.

Here the timeframe, for how fast the fan speeds increase with one step, is adjusted.

Here the maximum fan speeds or duct pressure for the boosting is set.

Out of the %RH menu.

8.7 PRESSURE CONTROL

The following menu is available for pressure control in home mode:

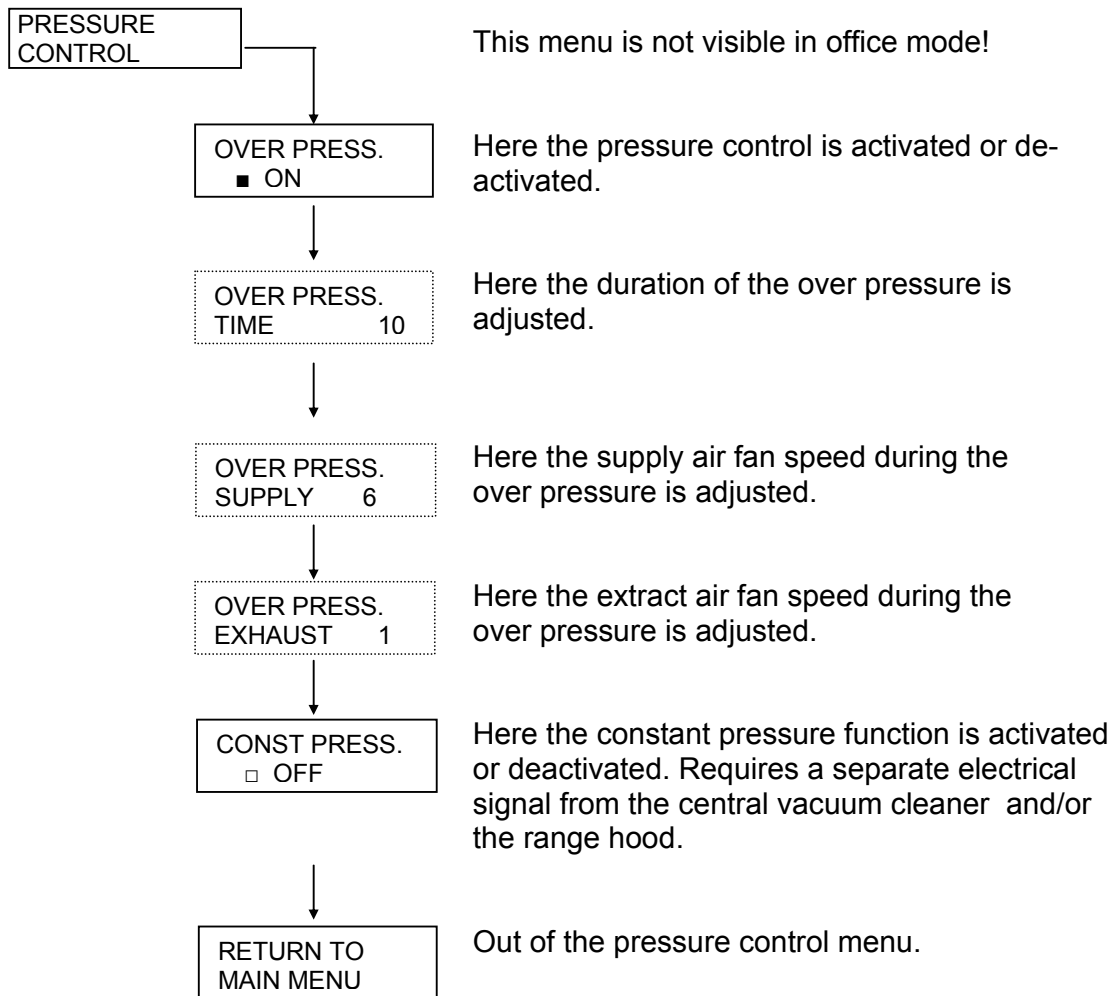

NOTE!

The heat recovery efficiency decreases when the over pressure and the constant pressure functions are active. This is due to the fact that the supply air increases in proportion to the extract air. This means that the supply air temperature decreases after the HRW. The ventilation units after heating (electrical or water) strives to keep the supply air temperature at the adjusted set value.

Use the range hood only when preparing food – and save heating energy!

8.8 SETTINGS

The following menu is available for the settings:

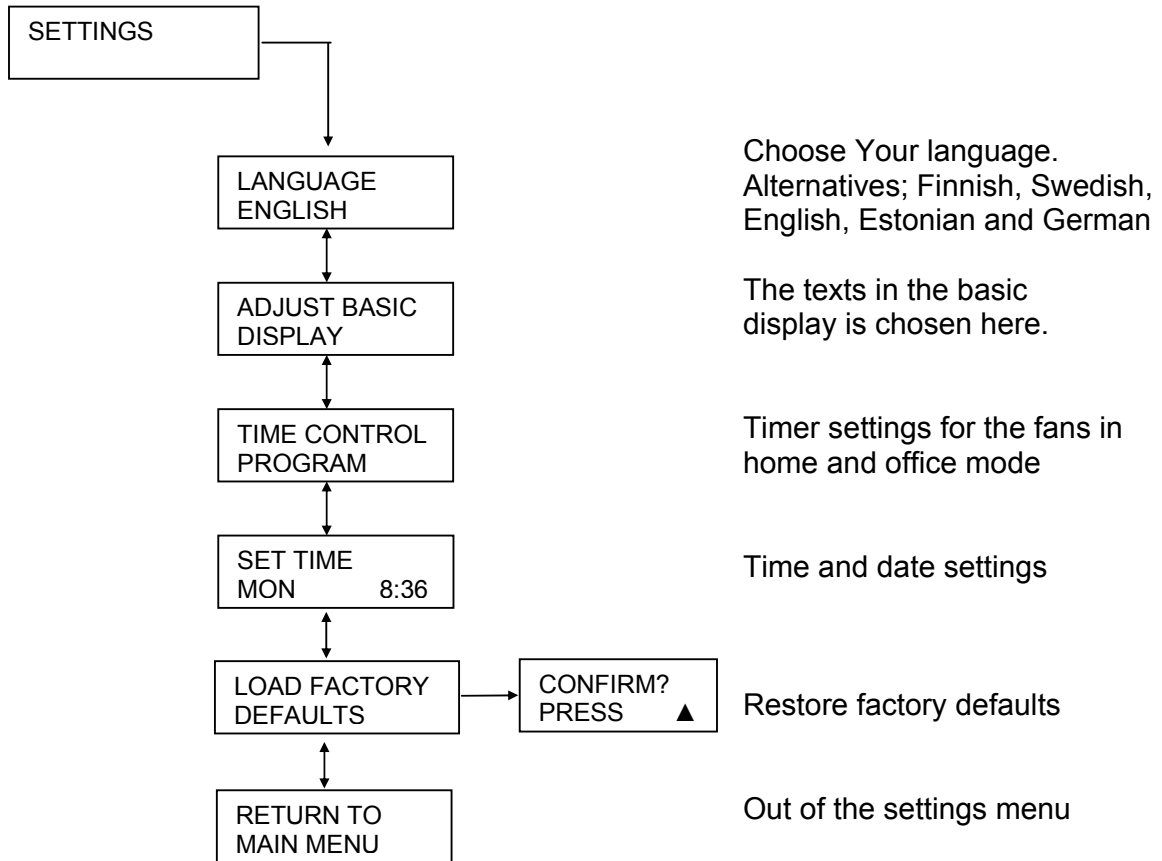

8.9 SERVICE MENU

The following menu is available for parameters that seldomly change:

The maintenance menu is entered by waiting 15 sec. at Settings and pressing ▲. Then press ENTER and give the code 6143.

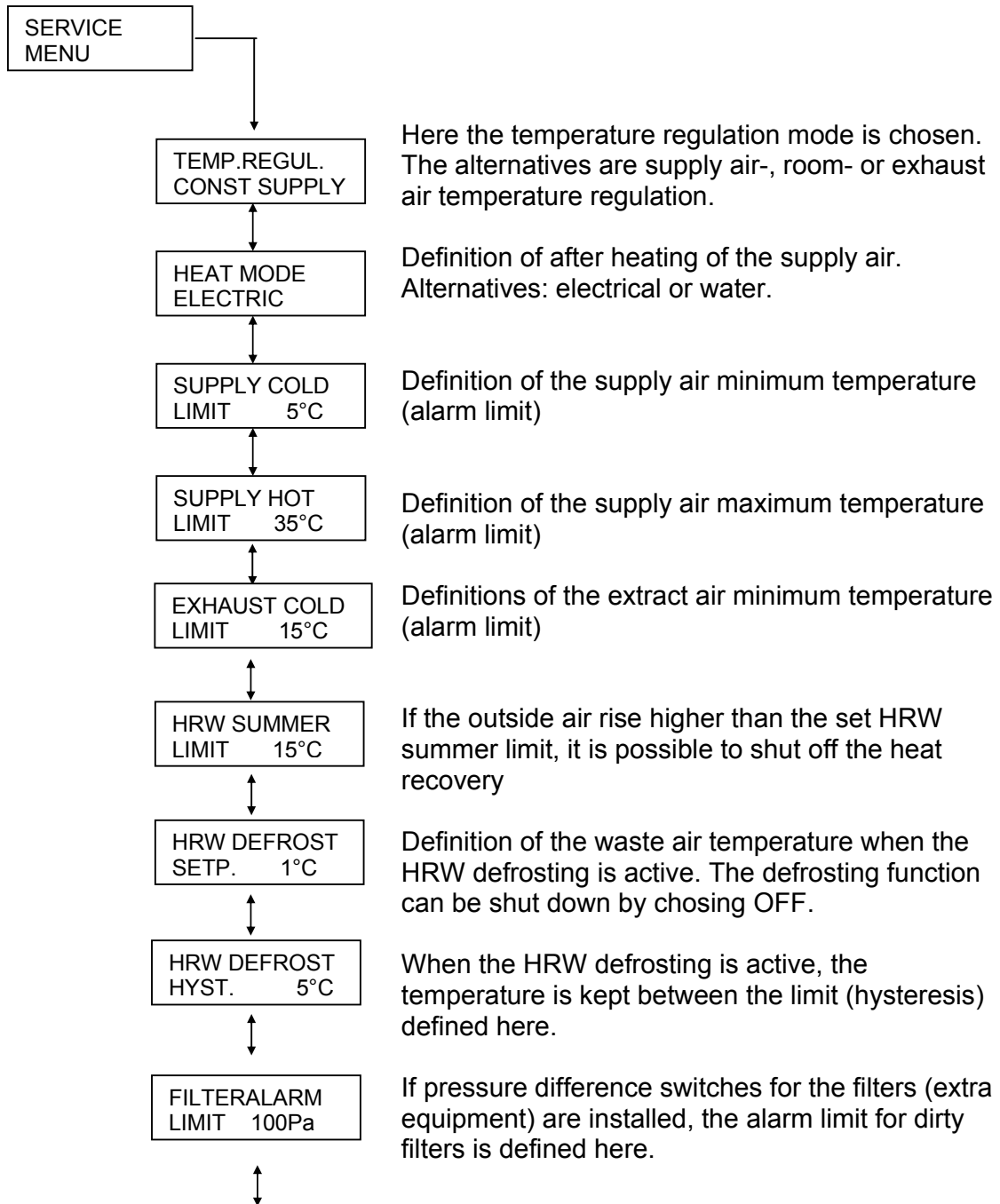

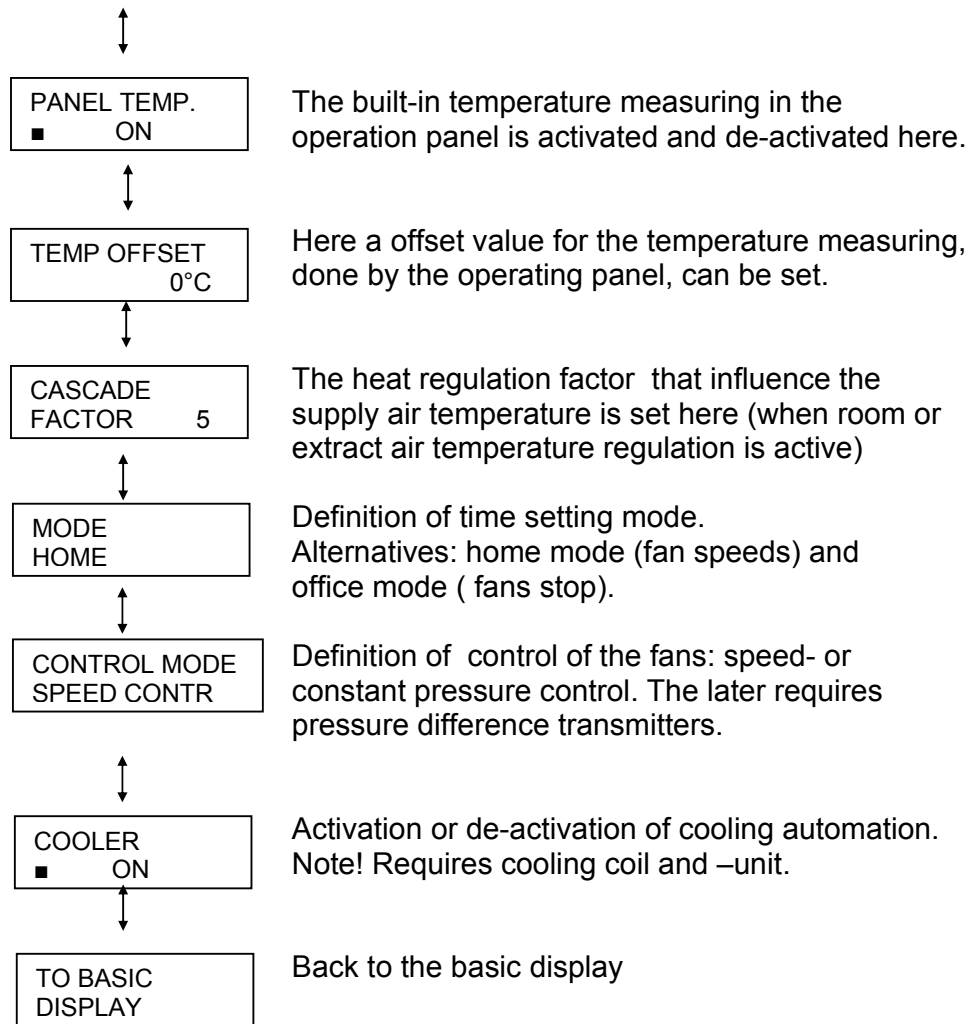

8.10 SETTING THE WEEKLY TIMER

The weekly timer allows the user to programme the fans to run at a certain speed, a certain day at a certain time. The weekly timer is in the SETTINGS-menu. The desired fan speed is defined in the FAN SPEEDS-menu.

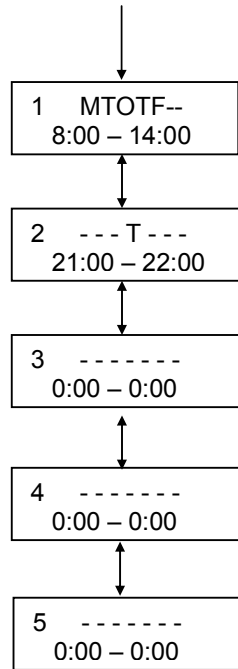

For example: The fans are programmed to run on desired speed Monday – Friday 08:00- 14:00.

For example: in addition the fans run at the desired speed Thursdays 21:00 – 22:00.

The weekly timer allows five different programme kombination.

8.11 EXPLANATION OF THE LIGHTS ON THE CONTROL PANEL

Light	HRW indicator light	Heater control indicator light	Maintenance / fault indicator light
Off	Heat exchanger does not rotate.	Heating regulation not in use. The unit does not heat or cool down the supply air.	No faults or warnings.
Green	Heat exchanger rotates.	Heating regulation active. The unit is heating or cooling down the supply air according to the function of the thermostat.	Summer night cooling or recovery of coolness active. (Also lights for a moment when programming of the control panel is started.)
Orange	-	-	Warning <ul style="list-style-type: none"> • Cold supply air • Hot supply air • Cold exhaust air • Filter
Red	-	-	Fault <ul style="list-style-type: none"> • Heat exchanger • Water heater / cooler • Electrical heater
Red	-	-	(Programming of messages)

9. TARGET VALUES FOR AIR FLOWS

Target values for air flows in the living areas.

EXTRACT AIR

Kitchen	20	l/s
Bathroom	15 –17	l/s
Toilet	10 –12	l/s
Clothing room	3 –4	l/s
Hobby room	0,7	l/s, m ²
Dressing room	2,0	l/s, m ²
Washroom	15 –17	l/s
Cleaning cupboard	4,0	l/s, m ²
Utility room	15 –17	l/s

SUPPLY AIR

Living room	8 –17 l/s	0,5 l/s, m ²
Bedroom	5 –8 l/s	0,7 l/s, m ²
Sauna	8 –17 l/s	2,0 l/s, m ²
Separate dining recess		0,5 l/s, m ²
Hobby room		0,7 l/s, m ²
Dressing room		2,0 l/s, m ²

10. KITCHEN VENTILATION

A normal cooker hood is installed over the kitchen stove. The hood should be used only when cooking. It is still necessary to install an extract vent, connected into the general ventilation system. The extract air volume should be 20 l/s.

The cooker hood should not be connected to the Pingvin ventilation unit.

11. TO BE OBSERVED DURING OPERATION!

Always ventilate with a high enough efficiency! Otherwise the indoor humidity will rise too high and condensation will form on for instance cold window surfaces.

The recommended relative humidity for indoor air is 40 ...45 % (room temperature 20...22 °C). At these levels condensation will not form and the humidity is at a healthy level. By monitoring the humidity of the indoor air with a humidity sensor, the ventilation can be increased when the humidity rises over 45%. Alternatively the ventilation can be reduced if the humidity of the indoor air falls below 40%.

Change the filters often enough! During the winter time the extract air filter becomes dirty more quickly than the fresh air filter. In this case the extract air flow will decrease, which then leads to a rise in the humidity, and also the decline of the incoming air temperature. With every filter inspection / change, check that the heat exchanger functions correctly.

12. HEAT RECOVERY EFFICIENCY

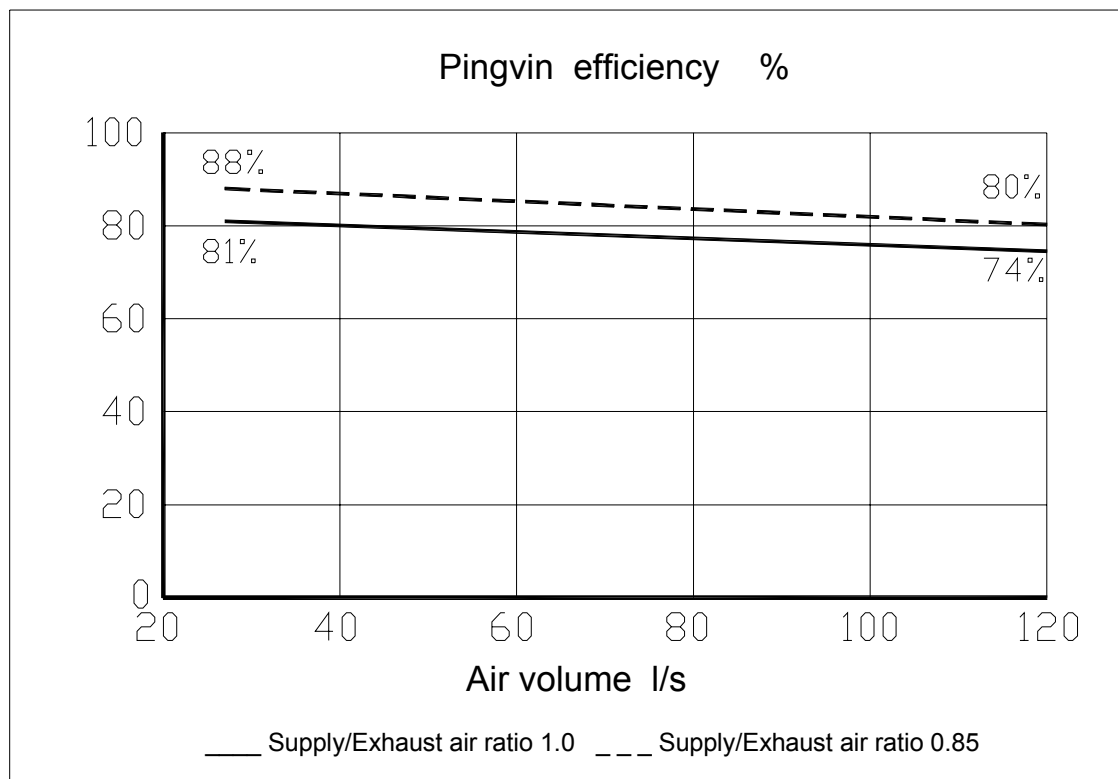

13. MAINTENANCE

Pingvin AC does not require any mechanical maintenance, only changing of the filters periodically and cleaning of the heat exchanger and fans (when needed). Before the maintenance is carried out, switch off the main power or unplug from the wall power supply.

The unit has been equipped with two hinged front doors. The main switch is located behind the smaller door; the filters are behind the larger door.

The small door is opened (and closed) by pressing the left edge inwards from the middle.

The large door will open when its two quick locks are turned anticlockwise about ½ turn. A screwdriver or a small coin can be used. Closing is the reversal of opening. The doors can be removed for easier access.

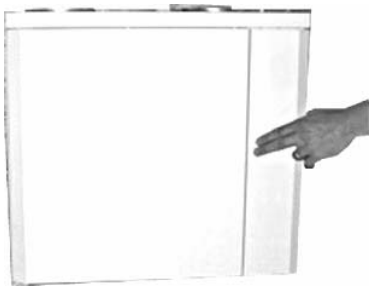

Opening the small door

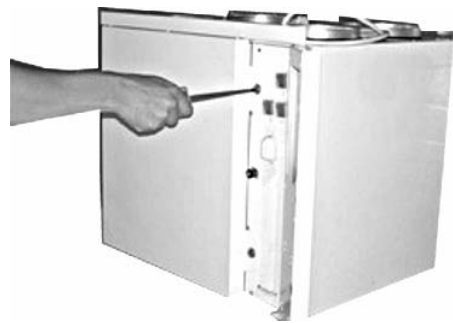

Opening the big door

Cleaning the heat exchanger. When changing the filters, check the condition of the heat exchanger. If cleaning is required, remove it from the machine and carefully wash through the air channels with a hand shower using a neutral detergent. The heat exchanger can also be cleaned by blowing through the air channels using compressed air. Do not use a pressure washer and do not submerge the heat exchanger into water!! When restarting the unit after cleaning, check that the rotor is turning freely.

Cleaning the fans. When changing filters, also check the condition of the fans. If cleaning is needed the fans are removed from the device and cleaned with a toothbrush or compressed air.

Changing of filters. The recommended time between filters changes is max four (4) months. Draw the filter cassettes from the device and loosen the filter fabric from the frame. Replace new filter fabric back into the frame. Press the filter cassette back into the machine so that the support network faces towards the heat exchanger. Vacuum-cleaning the inside of the device is recommended at this point.

14. BELT REPLACEMENT

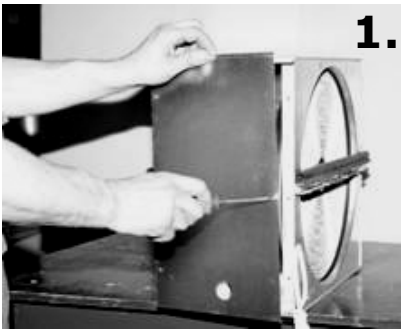

1.

- ✓ Heat recovery unit is stopped by switching off main supply from service switch, fuse or by disconnecting wall plug. Open the service hatch.
- ✓ Disconnect the heat recovery wheel plug.
- ✓ Pull the heat exchanger out from the ventilation unit.
- ✓ Open the screws in the one side of the heat exchanger and lift off the hatch. Lay down the heat exchanger on it's side. (Picture 1)



2.

- ✓ Turn the heat exchanger on the table so that the rotor shaft is in vertical position. Pull off the sealing rubber. (Picture 2)
- ✓ Open the hexagonal screw from the end of the shaft and the two screws from the u-profile.
- ✓ Lift off the u-profile.



3.

- ✓ Clean the outside of the heat exchanger and thrill the belt carefully inside the heat exchanger through the gasket. Rotate simultaneously the heat exchanger carefully. (Picture 3 and 4)
- ✓ Fasten the u-profile with the two screws and the hexagonal screw.
- ✓ Push the sealing rubber on it's place.



4.

- ✓ Turn the heat exchanger upwards and put the belt on the belt wheel. (Picture 5)
- ✓ Rotate the heat exchanger couple revolutions upwards seen from the motor.

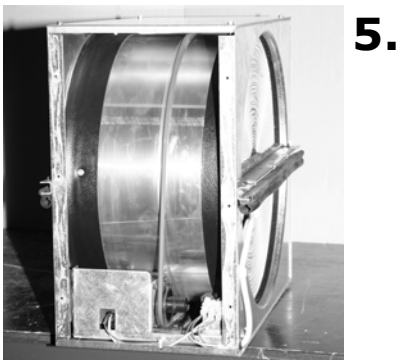

5.

- ✓ Clean the package inside.
- ✓ Fasten the hatch with the screws.
- ✓ Install the heat exchanger back to the ventilation unit and connect the plug.
- ✓ Switch on the main supply.
- ✓ Check visually that the heat exchanger rotates.
- ✓ Shut the service hatch.

15.CHARACTERISTICS

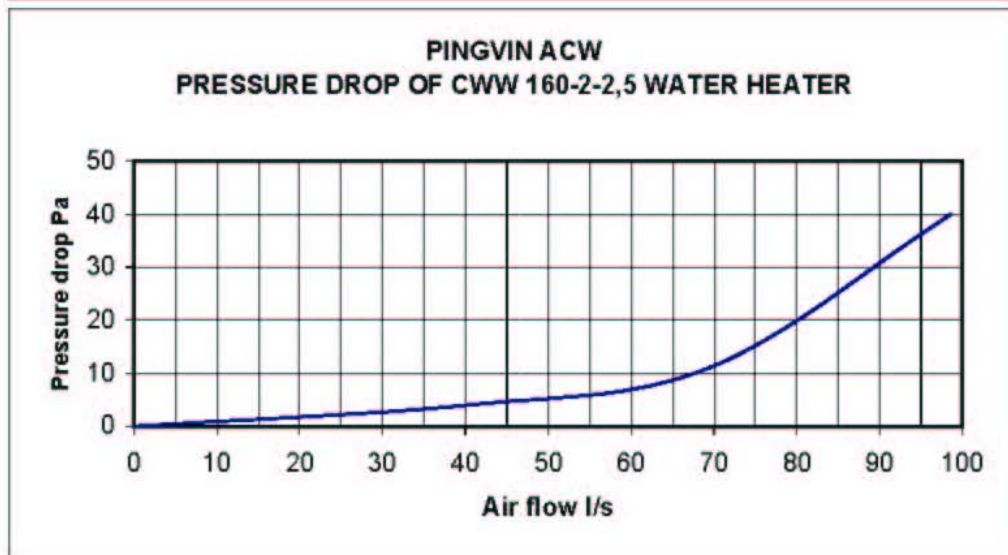
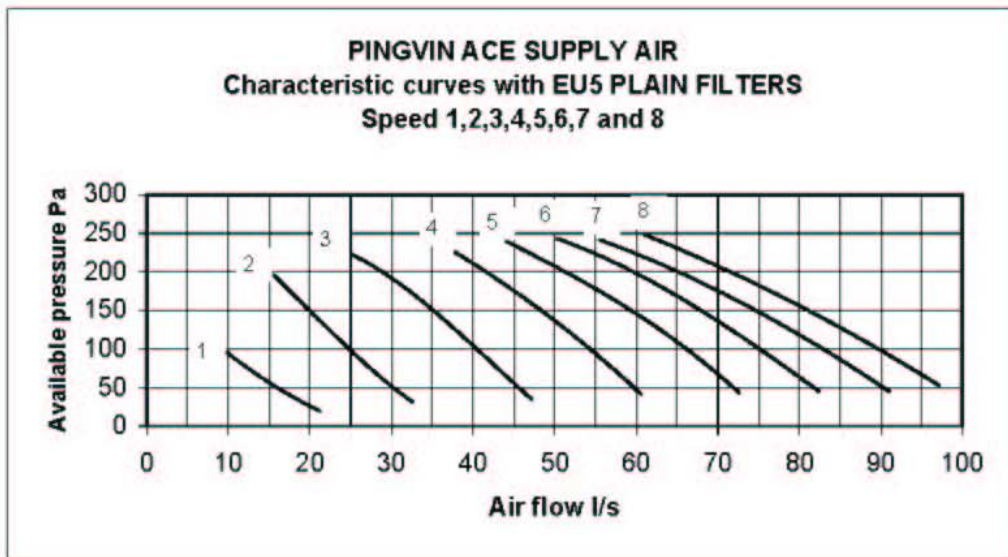
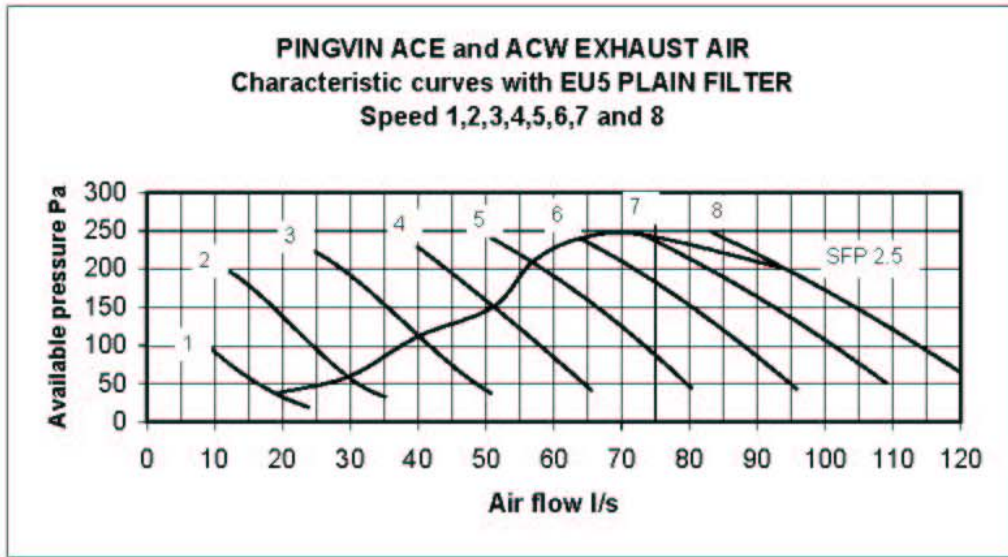

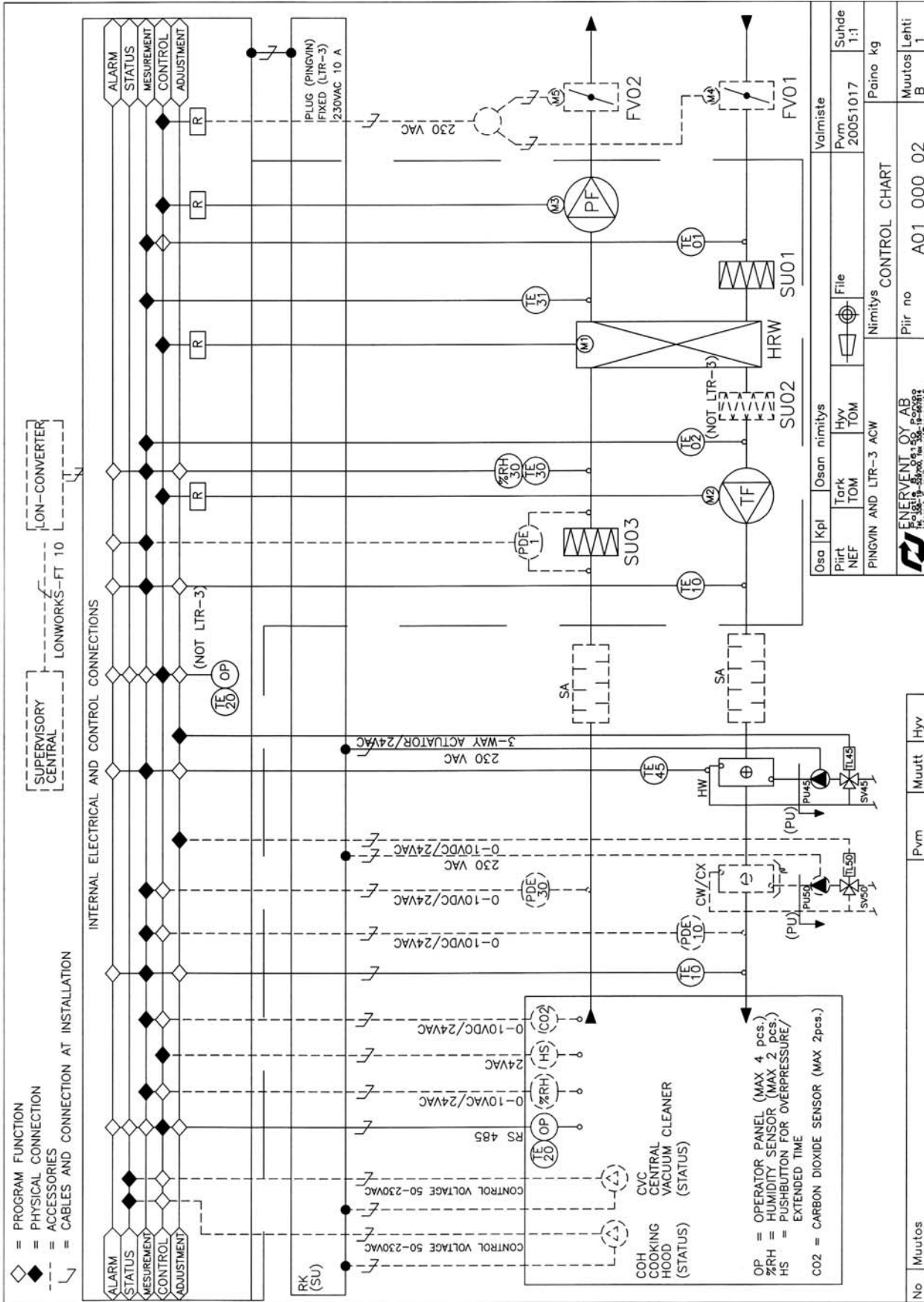

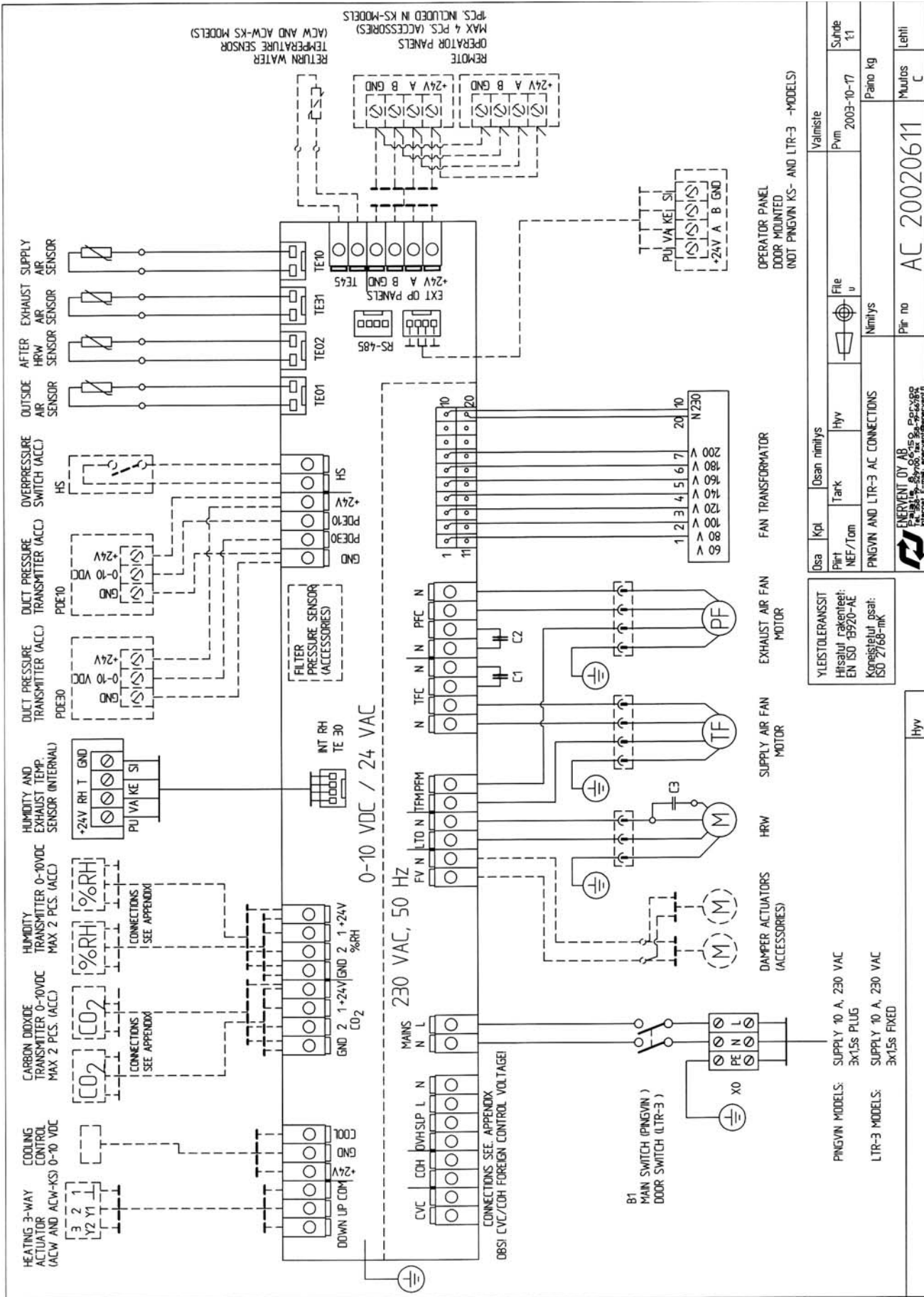

YLEISTOLERANSSIT
 Hteatul rakenteet:
 EN ISO 15920-AE
 Koneistulutusosat:
 ISO 2768-mK

ENERVENT OY AB
 Puhuri- ja ilmalämpöpumpun
 valmistaja
 Internet: www.enervent.fi

Yleiset tekniset tiedot
 PINGVIN AND LTR-3 AC CONNECTIONS

PINGVIN MODELS: SUPPLY 10 A, 230 VAC 3x15s PLUG
 LTR-3 MODELS: SUPPLY 10 A, 230 VAC 3x15s FIXED

Usa	Kpl	Dsan nimitys	Valmistaja
File	NEF/Tom	Tark	Pvm
File	NEF/Tom	hyv	2003-10-17
Nimitys			Paino kg
			Muutos C
			Lehti
			AC 20020611

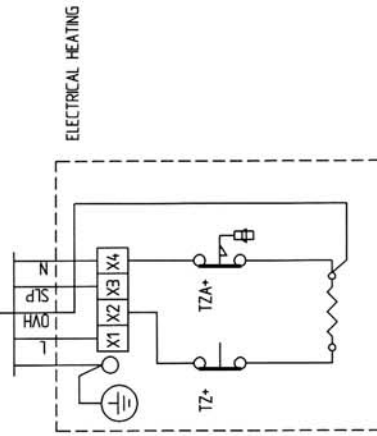
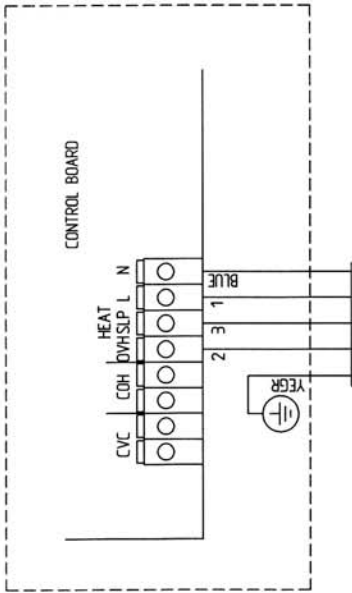

YLESTOLERANSSIT		Dosa		Kpl		Dosa nimitys		Vaimiste	
Hissalut rakenteet: EN ISO 19920-AE		Pir1 NEF/TOM	Tark TOM	ihyv TOM	File u	Pvm 2005-10-17		Suhte 1:1	
Konsistijut osat: ISO 2768-MK		ACE AND DCE -MODELS			Nimitys ELECTRICAL HEATING CONNECTION CHART		Paino Kg		Lehti
ENERVENT OY AB Puhelin: 08-0459-2222 Faksi: 08-0459-2223 www.enervent.fi		Pir no ACDC 20020612			Muuos B				
		ihyv							

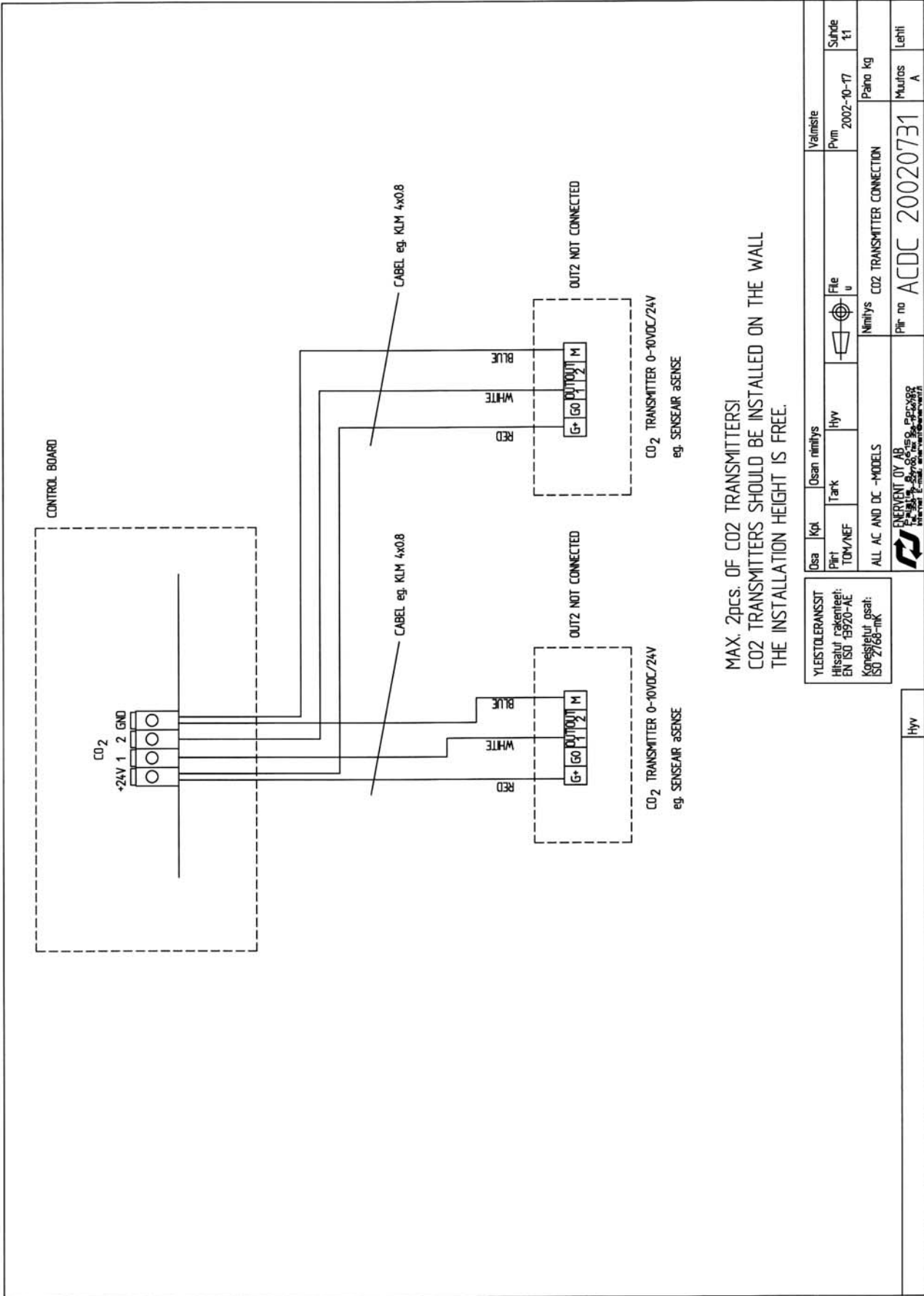

MAX. 2PCS. OF CO2 TRANSMITTERS!
 CO2 TRANSMITTERS SHOULD BE INSTALLED ON THE WALL
 THE INSTALLATION HEIGHT IS FREE.

YLEISTÖLÖRANSKAST		Osa		Kpl		Osaan nimitys		Vainiste	
Hissitulit rakenteille: EN ISO 19920-AE		Piiri	Tark	Hyv	File	u	Pvm	2002-10-17	Suhde
Käyttöselitys osat: ISO 2768-mK		ALL AC AND DC -MODELS		Nimitys		CO2 TRANSMITTER CONNECTION		Paino kg	
EVEREVENT OY AB P.O. Box 100, 00000, Helsinki, Finland www.everevent.com		Piiri no		ACDC		20020731		Muuos	
Hyv								A	
								Lehti	

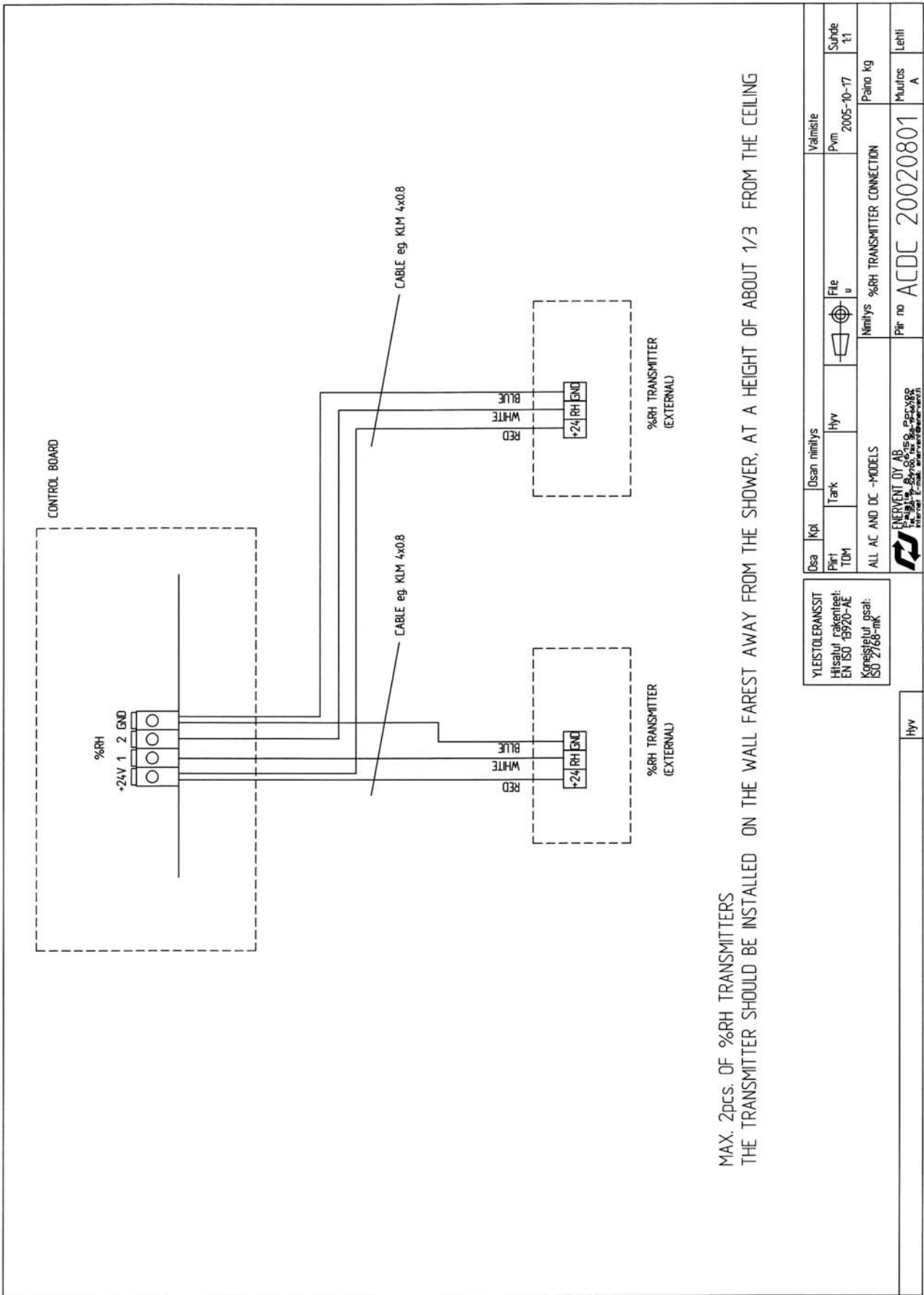

MAX. 2PCS. OF %RH TRANSMITTERS
 THE TRANSMITTER SHOULD BE INSTALLED ON THE WALL FAREST AWAY FROM THE SHOWER, AT A HEIGHT OF ABOUT 1/3 FROM THE CEILING

YLEISTÖLÉRANSITT Hälsutal räkenskap: EN ISO 15920-AE Kopierstatul osat: ISO 2768-mK		Dsa Kpt Dsan nimhys		Valmistie	
Pirt TDM		Tark	Hyv	File u	Pvm 2005-10-17
ALL AC AND DC -MODELS		Nimhys %RH TRANSMITTER CONNECTION		Paino kg	
ENERVENT DY AB Företagsnamn: Enervent Internat. E-mail: energent@enervent.se		Pir no ACDC 20020801		Muutos A	
Hyv				Lehti	

16.2 COH AND CVC INDICATION

General

The automation mechanically controls the fan speeds if a 50-230 VAC control current has been connected to the COH or CVC connector on the control card.

COH, indicates the running of the range hood

Wiring alternative 1. Indication directly from the motor of the range hood

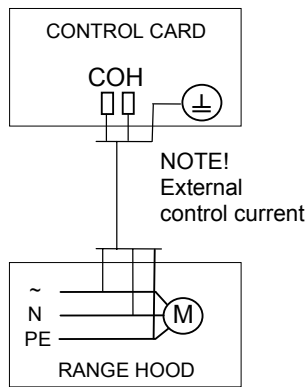

Wiring alternative 2. Indication with pressure-difference switch from the range hood

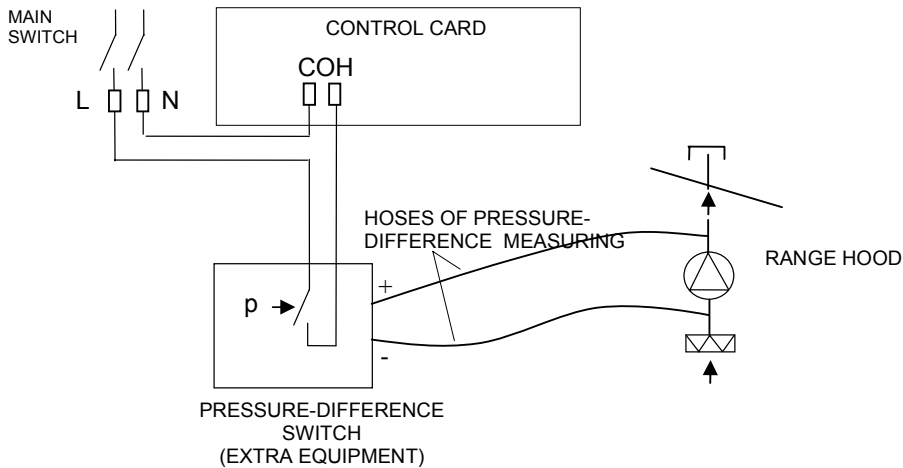

Wiring alternative 3. Indication with the micro switch of the range hood

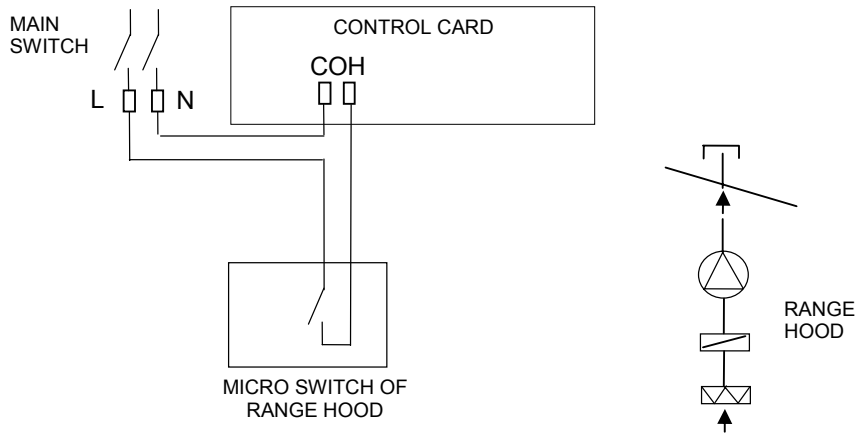

CVC, indicates the running of the central vacuum cleaner

Wiring alternative 1. Indication directly from the motor of the central vacuum cleaner

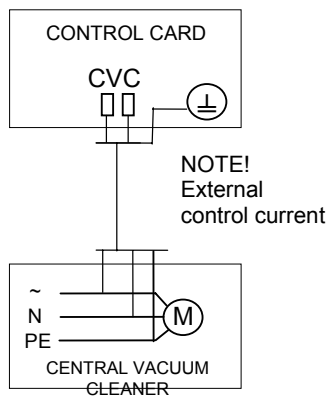

Wiring alternative 2. Indication with pressure-difference switch from the vacuum cleaner

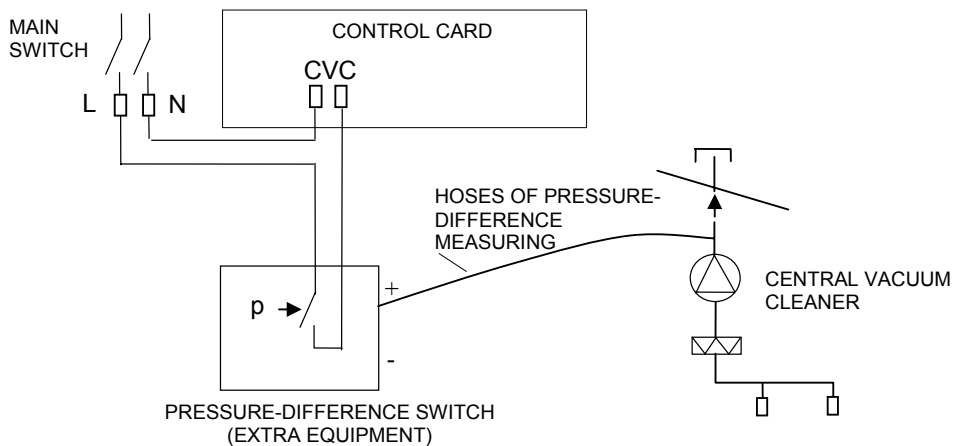

16.3 OUTER CABLING OF THE VENTILATION UNIT CONTROL

ACE automation

Code	Explanation	Delivered	Current	Cabel example
OP	Control panel, max 4 pcs	1 pcs standard	RS485 led	KLM 4x0.8
TE20	Room temperature sensor	Included in OP	max 2 V	-
%RH	Humidity transmitter, max 2 pcs	Extra equipment	0-10 V / 24 V	KLM 4x0.8
CO ₂	Carbon dioxide transmitter, max 2 pcs	Extra equipment	0-10 V / 24 V	KLM 4x0.8
HS	Manual push switch for over pressure control or extended time	Extra equipment	max. 24 V	KLM 2x0.8
COH	Range hood, operational condition	Needs cabling	50-230 V	MMJ 3x1.5s
CVC	Central vacuum cleaner, operational condition	Needs cabling	50-230 V	MMJ 3x1.5s
FV01	Outside air damper, damper motor	Extra equipment	230 V	MMJ 3x1.5s
FV02	Waste air damper, damper motor	Extra equipment	230 V	MMJ 3x1.5s
PDE10	Pressure transmitter of supply air duct	Extra equipment	0-10 V / 24 V	KLM 4x0.8
PDE30	Pressure transmitter of exhaust air duct	Extra equipment	0-10 V / 24 V	KLM 4x0.8
PU50	Water pump (cooling)	Extra equipment	230 V	MMJ 3x1.5s
SV50	Control valve for cooling water	Extra equipment	-	-
TL50	Regulator for the cooling water control valve	Extra equipment	0-10 V / 24 V	KLM 4x0.8
CW	Cooler cw (water), for intstallation in duct	Extra equipment	-	-
CX	Cooler dx (evaporator), for installation in duct	Extra equipment	-	-
TE10	Supply air temperature sensor for cooling, duct	Extra equipment	max. 2 V	KLM 2x0.8

The control panel of the ACE-KS models is delivered uninstalled. The Pingvin ACE-KS unit is class IP44 and can consequently be installed in a humid facility. The class IP20 control panel must be installed in a dry facility.

The low current cables must absolutely be kept apart from the high current cables!

ACW automation

Code	Explanation	Delivered	Current	Cabel example
OP	Control panel, max 4 pcs	1 pcs standard	RS485 led	KLM 4x0.8
TE20	Room temperature sensor	Included in OP	max 2 V	-
%RH	Humidity transmitter, max 2 pcs	Extra equipment	0-10 V / 24 V	KLM 4x0.8
CO ₂	Carbon dioxide transmitter, max 2 pcs	Extra equipment	0-10 V / 24 V	KLM 4x0.8
HS	Manual push switch for over pressure control or extended time	Extra equipment	max. 24 V	KLM 2x0.8
COH	Range hood, operational condition	Needs cabling	50-230 V	MMJ 3x1.5s
CVC	Central vacuum cleaner, operational condition	Needs cabling	50-230 V	MMJ 3x1.5s
FV01	Outside air damper, damper motor	Extra equipment	230 V	MMJ 3x1.5s
FV02	Waste air damper, damper motor	Extra equipment	230 V	MMJ 3x1.5s
PDE10	Pressure transmitter of supply air duct	Extra equipment	0-10 V / 24 V	KLM 4x0.8
PDE30	Pressure transmitter of exhaust air duct	Extra equipment	0-10 V / 24 V	KLM 4x0.8
HW	Waterheater for installation in duct	Standard equipment	-	-
PU45	Water heater pump	Extra equipment	230 V	MMJ 3x1.5s
SV45	Control valve for heating water	Standard equipment	-	-
TL45	Regulator for the heating water control valve	Standard equipment	3-point / 24 V	KLM 4x0.8
TE45	Heating return water temperature sensor	Standard equipment	max 2 V	KLM 2x0.8
TE10	Supply air temperature sensor, for installation in duct	Standard equipment	max 2 V	KLM 2x0.8
PU50	Water cooler pump	Extra equipment	230 V	MMJ 3x1.5s
SV50	Control valve for cooling water	Extra equipment	-	-
TL50	Regulator for the cooling water control valve	Extra equipment	0-10 V / 24 V	KLM 4x0.8
CW	Cooler cw (water), for intstallation in duct	Extra equipment	-	-
CX	Cooler dx (evaporator), for installation in duct	Extra equipment	-	-

The control panel of the ACW-KS models is delivered uninstalled. The Pingvin ACW-KS unit is class IP44 and can consequently be installed in a humid facility. The calss IP20 control panel must be installed in a dry facility.

The low current cables must absolutely be kept apart from the high current cables!

17. FAULT / CORRECTION GUIDE

INCOMING AIR TOO COLD

<i>Reason</i>	<i>Action</i>
* The rotor switch is in position 0	☛ Switch to position 1
* Belt of the heat exchanger broken	☛ Replace the belt
* Belt greasy, causing slippage	☛ Contact a service man
* The exhaust fan has stopped	☛ Contact a service man
* The exhaust air filter is blocked	☛ Change the exhaust air filter
* Exhaust air vents settings incorrect	☛ Contact a service man
* Heat insulation of ducts inadequate	☛ Check the insulation thickness of the supply and exhaust air ducts and add insulation if needed.

AIR FLOW BECOMES SMALLER

<i>Reason</i>	<i>Action</i>
* Filters are blocked	☛ Change the filters
* Speed selector switch of the fans has been turned down	☛ Select higher speed
* Blockage in the fresh air grille	☛ Clean the outer grille
* Fan wings dirty	☛ Clean the fans

OPERATING SOUND LEVEL INCREASED

<i>Reason</i>	<i>Action</i>
* Filters blocked	☛ Change the filters
* Outer grilles are blocked	☛ Clean the outer grille
* Fan bearings faulty	☛ Change bearings / contact service
* Problem with gear/motor of the heat exchanger	☛ Contact a service man
* Fan wings dirty	☛ Clean the fans

Note! Also read “Explanation of the lights on the control panel”, page 29.

18. TECHNICAL INFORMATION

Dimensions											
Height	537 mm										
Width	580 mm										
Depth	500 mm										
Current	230 V / 50 Hz 1-fase Fuse 10 A, quick										
Control card fuses	F1 T63mA glass tube 5x20 F2 T1,6A glass tube 5x20										
Fans Exhaust air	All models Rating 185 W max. Current 0,8 A Heat protection										
Supply air	Rating 185 W max. Current 0,8 A Heat protection										
Heat exchanger motor	Rating 25 W 0,09 A Heat protection										
Duct size	All models Ø 160 mm										
Weight	50 kg										
<p>Sound level</p> <p>Sound levels from the unit in a room where it is installed. Voice absorption of 10 m².</p> <table border="1"> <thead> <tr> <th>Fan speed</th> <th>Sound level</th> </tr> </thead> <tbody> <tr> <td>Position 3</td> <td>29 dB (A)</td> </tr> <tr> <td>Position 5</td> <td>36 dB (A)</td> </tr> <tr> <td>Position 7</td> <td>43 dB (A)</td> </tr> <tr> <td>Position 8</td> <td>49 dB (A)</td> </tr> </tbody> </table>		Fan speed	Sound level	Position 3	29 dB (A)	Position 5	36 dB (A)	Position 7	43 dB (A)	Position 8	49 dB (A)
Fan speed	Sound level										
Position 3	29 dB (A)										
Position 5	36 dB (A)										
Position 7	43 dB (A)										
Position 8	49 dB (A)										